



State of New Jersey

DEPARTMENT OF ENVIRONMENTAL PROTECTION

PHILIP D. MURPHY
Governor

DIVISION OF WATERSHED PROTECTION AND RESTORATION
BUREAU OF NJPDES STORMWATER PERMITTING & WATER QUALITY MANAGEMENT

SHAWN M. LATOURETTE
Commissioner

SHEILA Y. OLIVER
Lt. Governor

P.O. Box 420 Mail Code 401-02B
Trenton, New Jersey 08625-0420
609-633-7021 / Fax: 609-777-0432

www.njstormwater.org

June 10, 2021

Zachariha J. Kent
Vice President of Product Management
Bio Clean Environmental Inc.
398 Via El Centro
Oceanside, CA 92058

Re: MTD Lab Certification
SciCloneX Hydrodynamic Separator by Bio Clean Environmental, Inc.
On-line Installation

TSS Removal Rate 50%

Dear Mr. Kent:

The Stormwater Management rules under N.J.A.C. 7:8-5.2(f) and 5.2(j) allow the use of manufactured treatment devices (MTDs) for compliance with the design and performance standards at N.J.A.C. 7:8-5 if the pollutant removal rates have been verified by the New Jersey Corporation for Advanced Technology (NJCAT) and have been certified by the New Jersey Department of Environmental Protection (NJDEP). Bio Clean Environmental, Inc. has requested an MTD Laboratory Certification for the SciCloneX Hydrodynamic Separator (SciCloneX HDS).

The project falls under the "Procedure for Obtaining Verification of a Stormwater Manufactured Treatment Device from New Jersey Corporation for Advance Technology" dated January 25, 2013. The applicable protocol is the "New Jersey Laboratory Testing Protocol to Assess Total Suspended Solids Removal by a Hydrodynamic Sedimentation Manufactured Treatment Device" dated January 25, 2013.

NJCAT verification documents submitted to the NJDEP indicate that the requirements of the protocol have been met or exceeded. The NJCAT letter also included a recommended certification TSS removal rate and the required maintenance plan. The NJCAT Verification Report dated May 2021 with the Verification Appendix for this device is published online at <http://www.njcat.org/verification-process/technology-verification-database.html>.

The NJDEP certifies the use of the SciCloneX HDS by Bio Clean Environmental, Inc. at a TSS removal rate of 50% when designed, operated and maintained in accordance with the information provided in the Verification Appendix and the following conditions:

1. The maximum treatment flow rate (MTFR) for the manufactured treatment device (MTD) is calculated using the New Jersey Water Quality Design Storm (1.25 inches in 2 hrs) in N.J.A.C. 7:8-5.5.
2. The SciCloneX HDS shall be installed using the same configuration reviewed by NJCAT and shall be sized in accordance with the criteria specified in in item 6 below.
3. This SciCloneX HDS cannot be used in series with another MTD or a media filter (such as a sand filter), to achieve an enhanced removal rate for total suspended solids (TSS) removal under N.J.A.C. 7:8-5.5.
4. Additional design criteria for MTDs can be found in Chapter 11.3 of the New Jersey Stormwater Best Management Practices (NJ Stormwater BMP) Manual which can be found on-line at www.njstormwater.org.
5. The maintenance plan for a site using this device shall incorporate, at a minimum, the maintenance requirements for the SciCloneX HDS, which is attached to this document. However, it is recommended to review the maintenance manual at https://biocleanenvironmental.com/wp-content/uploads/2021/03/SciCloneX-Operation-Maintenance-Manual_3-23-2021-v1.pdf for any changes to the maintenance requirements.
6. Sizing Requirements:

The example below demonstrates the sizing procedure for the SciCloneX HDS:

Example: A 0.25-acre impervious site is to be treated to 50% TSS removal using a SciCloneX HDS. The impervious site runoff (Q) based on the New Jersey Water Quality Design Storm was determined to be 0.79 cfs.

Maximum Treatment Flow Rate (MTFR) Evaluation:

The site runoff (Q) was based on the following:

time of concentration = 10 minutes
 $i=3.2$ in/hr (page 21, Fig. 5-10 of Chapter 5 of the NJ Stormwater BMP Manual)
 $c=0.99$ (curve number for impervious)
 $Q=ciA=0.99 \times 3.2 \times 0.25=0.79$ cfs

Given the site runoff is 0.79 cfs and based on Table 1 below, the SciCloneX HDS Model SCX-3 with a MTFR of 1.02 cfs would be the smallest model approved that could be used for this site that could remove 50% of the TSS from the impervious area without exceeding the MTFR.

The sizing table corresponding to the available system models is noted below. Additional specifications regarding each model can be found in the Verification Appendix under Table A-1 and Table A-2.

Table 1 SciCloneX HDS Models

SciCloneX HDS Model	Manhole Diameter (ft)	Maximum Treatment Flowrate, MTFR (cfs)
SCX-3	3	1.02
SCX-4	4	1.82
SCX-5	5	2.84
SCX-6	6	4.09
SCX-7	7	5.56
SCX-8	8	7.27
SCX-10	10	11.36
SCX-12	12	16.35
SCX-14	14	22.25

Be advised a detailed maintenance plan is mandatory for any project with a Stormwater BMP subject to the Stormwater Management Rules, N.J.A.C. 7:8. The plan must include all the items identified in the Stormwater Management Rules, N.J.A.C. 7:8-5.8. Such items include, but are not limited to, the list of inspection and maintenance equipment and tools, specific corrective and preventative maintenance tasks, indication of problems in the system, and training of maintenance personnel. Additional information can be found in Chapter 8: Maintenance and Retrofit of Stormwater Management Measures.

If you have any questions regarding the above information, please contact Lisa Schaefer of my office at lisa.schaefer@dep.nj.gov.

Sincerely,



Gabriel Mahon, Chief
 Bureau of NJPDES Stormwater Permitting & Water Quality Management
 Division of Watershed Protection and Restoration
 New Jersey Department of Environmental Protection

Attachment: Maintenance Plan

cc: Richard Magee, NJCAT



SciCloneX™ Separator

A Stormwater Separation Solution

OPERATION & MAINTENANCE MANUAL



OPERATION & MAINTENANCE

The SciCloneX™ Separator is designed to remove high levels of trash, debris, sediments and hydrocarbons. Its efficient design and construction maximize longevity and minimize maintenance requirements. The simple design of the system allows for unimpeded access for quick and easy maintenance. The SciCloneX™ Separator is able to effectively capture and store sediment with no maintenance or loss of treatment capacity for several years based on annual average loading in most regions.

Yet, as with all stormwater BMPs inspection and maintenance on the SciCloneX™ Separator is necessary. Stormwater regulations require that all BMPs be inspected and maintained to ensure they are operating as designed to allow for effective pollutant removal and provide protection to receiving water bodies. It is recommended that inspections be performed multiple times during the first year to assess site-specific loading conditions.

This is recommended because pollutant loading can vary greatly from site to site. Variables such as nearby soil erosion or construction sites, winter sanding of roads, amount of daily traffic and land use can increase pollutant loading on the system. The first year of inspections can be used to set inspection and maintenance intervals for subsequent years. Without appropriate maintenance a BMP can exceed its storage capacity which can negatively affect its continued performance in removing and retaining captured pollutants.

System Diagrams:

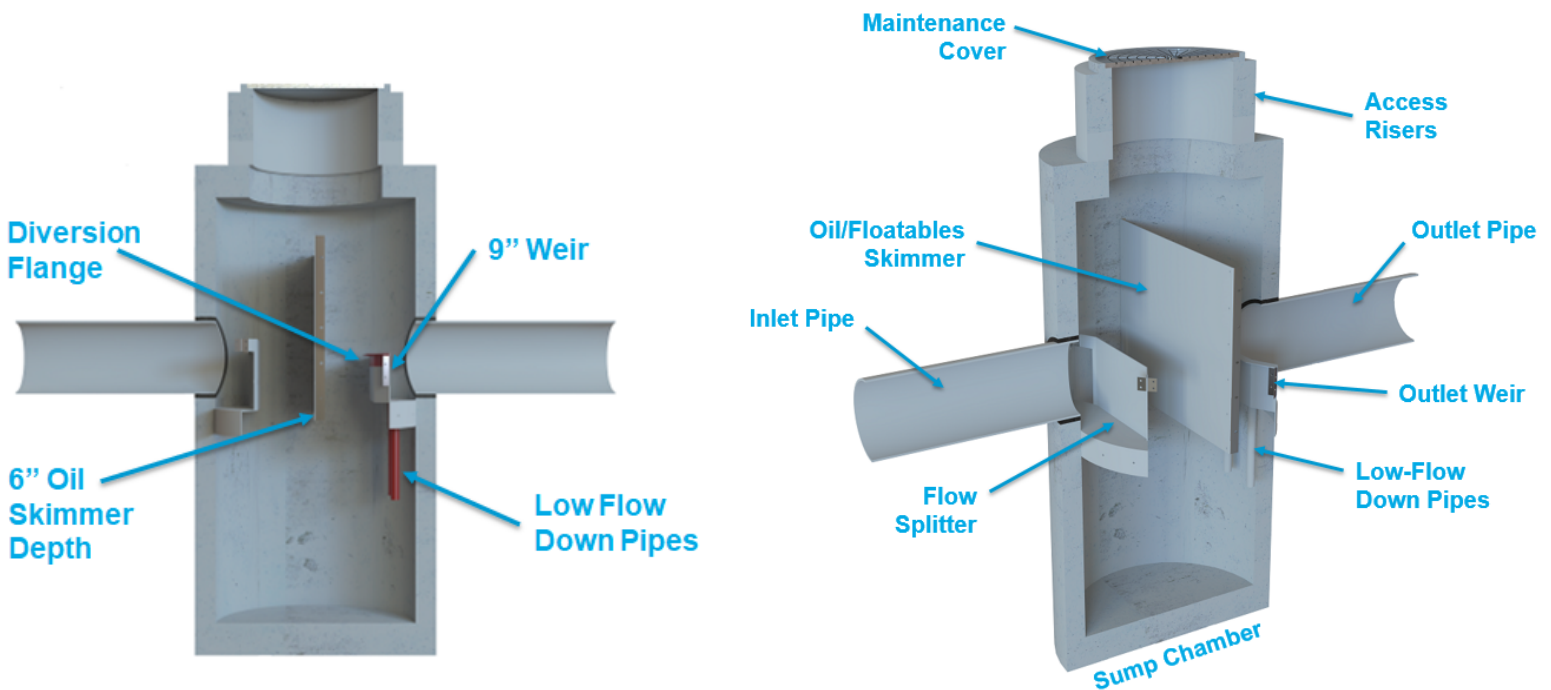

Inspection Equipment

Following is a list of equipment to allow for simple and effective inspection of the SciCloneX™ Separator:

- Bio Clean Environmental Inspection Form (contained within this manual).
- Flashlight.
- Manhole hook or appropriate tools to remove access hatches and covers.
- Appropriate traffic control signage and procedures.
- Measuring pole and/or tape measure.
- Protective clothing and eye protection.
- Note: entering a confined space requires appropriate safety and certification. It is generally not required for routine inspections or maintenance of the system.

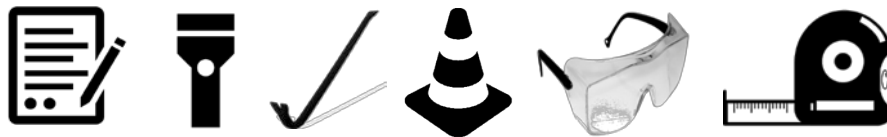

Inspection Steps

The core to any successful stormwater BMP maintenance program is routine inspections. The inspection steps required on the SciCloneX™ Separator are quick and easy. As mentioned above the first year should be seen as the maintenance interval establishment phase. During the first year more frequent inspections should occur in order to gather loading data and maintenance requirements for that specific site. This information can be used to establish a base for long-term inspection and maintenance interval requirements.

The SciCloneX™ Separator can be inspected through visual observation without entry into the system. All necessary pre-inspection steps must be carried out before inspection occurs, especially traffic control and other safety measures to protect the inspector and near-by pedestrians from any dangers associated with an open access hatch or manhole. Once these access covers have been safely opened the inspection process can proceed:

- Prepare the inspection form by writing in the necessary information including project name, location, date & time, unit number and other info (see inspection form).
- Observe the inside of the system through the access hatches. If minimal light is available and vision into the unit is impaired utilize a flashlight to see inside the system.
- Look for any out of the ordinary obstructions in the inflow pipe, sump chamber, or outflow pipe. Write down any observations on the inspection form.
- Through observation, and/or digital photographs, estimate the amount of floatable debris accumulated on the influent side of the oil/floatables skimmer. Record this information on the inspection form. Next utilizing a tape measure or measuring stick estimate the amount of sediment accumulated in the sump. Record this depth on the inspection form.

- Finalize inspection report for analysis by the maintenance manager to determine if maintenance is required.

Maintenance Indicators

Based upon observations made during inspection, maintenance of the system may be required based on the following indicators:

- Missing or damaged internal components.
- Obstructions in the system or its inlet or outlet.
- Excessive accumulation of floatables in the sump chambers in which the length and width of the chambers behind oil/floatables skimmer is fully impacted extending down more than 9”.
- Excessive accumulation of sediment in the sump chamber of more than 18” in depth.

Maintenance Equipment

It is recommended that a vacuum truck be utilized to minimize the time required to maintain the SciCloneX™ Separator :

- Bio Clean Environmental Maintenance Form (contained in O&M Manual).
- Flashlight.
- Manhole hook or appropriate tools to access hatches and covers.
- Appropriate traffic control signage and procedures.
- Protective clothing and eye protection.
- Note: entering a confined space requires appropriate safety and certification. It is generally not required for routine maintenance of the system.
- Vacuum truck (with pressure washer attachment preferred).

Maintenance Procedures

It is recommended that maintenance occurs at least three days after the most recent rain event to allow for drain down of any associated upstream detention systems. Maintaining the system while flows are still entering it will increase the time and complexity required for maintenance. Cleaning of the sump chamber can be performed from finish surface without entry into the vault utilizing a vacuum truck. Once all safety measures have been set up cleaning of the sump chamber can proceed as followed:

- Remove all access hatches (requires traffic control and safety measures to be completed prior).
- Using an extension on a vacuum truck position the hose over the opened access hatch and lower into the center of the sump chamber on the inlet side of the oil/floatables skimmer.

Remove all floating debris, standing water and sediment from the sump chamber. Access to the bottom of the sump chamber is unimpeded. The vac hose can be moved from side-to-side to fully remove sediments at the corners. A power washer can be used to assist if sediments have become hardened and stuck to the walls or the floor of the chamber. Repeat the same procedure on the effluent side of the oil/floatables skimmer to remove any remaining sediment. This completes the maintenance procedure required on the sump chamber and the SciCloneX™ Separator.

- The last step is to close up and replace all access hatches and remove all traffic control.
- All removed debris and pollutants shall be disposed of following local and state requirements.
- Disposal requirements for recovered pollutants may vary depending on local guidelines. In most areas the sediment, once dewatered, can be disposed of in a sanitary landfill. It is not anticipated that the sediment would be classified as hazardous waste.
- In the case of damaged components, replacement parts can be ordered by the manufacturer.

Maintenance Sequence



Remove Access Hatches Set Up Vacuum Truck to Clean the Sump Chamber.

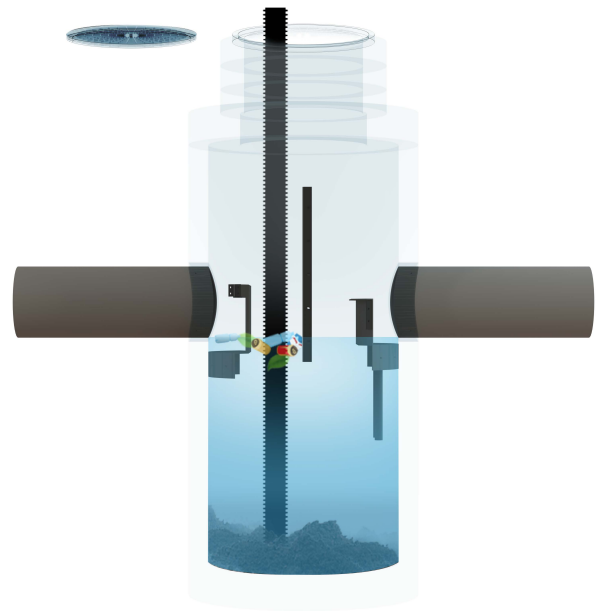

Insert Vacuum Hose On the Inlet Side of the Oil/Floatables Skimmer and Vacuum Out All Trash, Sediment and Standing Water.

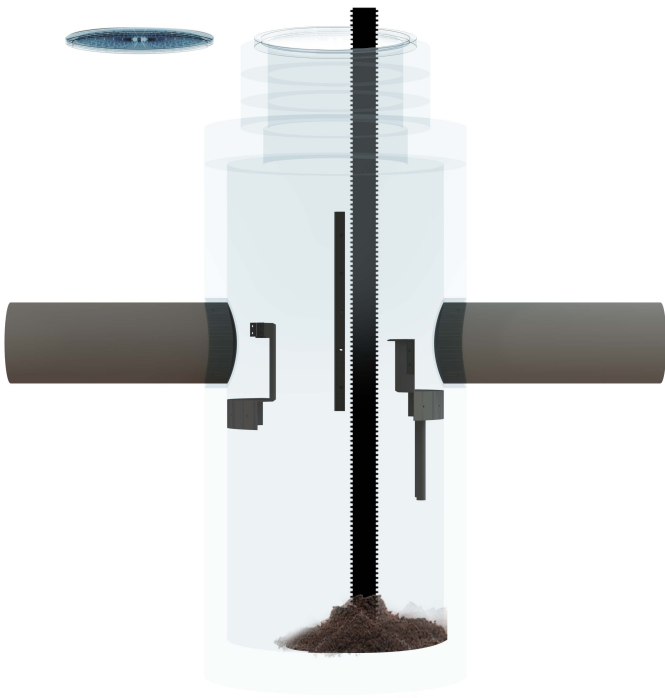

Insert Vacuum Hose On the Outlet Side of the Oil/Floatables Skimmer and Vacuum Out Any Remaining Sediment.



Replace Access Hatches and Remove Traffic Control and Safety Equipment.

For Maintenance Services or Information Please Contact Us At:
760-433-7640
Or Email: stormwater@forterrabp.com

Inspection and Maintenance Report Bio Clean SciCloneX™ Separator

Project Name _____

Project Address _____ (city) (Zip Code)

Owner / Management Company _____

Contact _____ Phone () - _____

Inspector Name _____ Date ____ / ____ / _____ Time _____ AM / PM

Type of Inspection Routine Follow Up Complaint Stor Storm Event in Last 72-hours? No Yes

Weather Condition _____ Additional Notes _____

For Office Use Only
(Reviewed By)
(Date) Office personnel to complete section to the left.

Site Map #	GPS Coordinates of Vault	Model #	Oils and Floatables Accumulation on Inlet Side of Oil/Floatables Skimmers (lbs)	Sediment Accumulation In Sump Chamber (lbs) & Depth (inches)	Structural Notes	Operational Per Manufactures' Specifications (If not, why?)
	Lat: _____ Long: _____					
	Lat: _____ Long: _____					
	Lat: _____ Long: _____					

Comments: _____



SciCloneX™ Separator

A Stormwater Separation Solution

OPERATION & MAINTENANCE MANUAL



OPERATION & MAINTENANCE

The SciCloneX™ Separator is designed to remove high levels of trash, debris, sediments and hydrocarbons. Its efficient design and construction maximize longevity and minimize maintenance requirements. The simple design of the system allows for unimpeded access for quick and easy maintenance. The SciCloneX™ Separator is able to effectively capture and store sediment with no maintenance or loss of treatment capacity for several years based on annual average loading in most regions.

Yet, as with all stormwater BMPs inspection and maintenance on the SciCloneX™ Separator is necessary. Stormwater regulations require that all BMPs be inspected and maintained to ensure they are operating as designed to allow for effective pollutant removal and provide protection to receiving water bodies. It is recommended that inspections be performed multiple times during the first year to assess site-specific loading conditions.

This is recommended because pollutant loading can vary greatly from site to site. Variables such as nearby soil erosion or construction sites, winter sanding of roads, amount of daily traffic and land use can increase pollutant loading on the system. The first year of inspections can be used to set inspection and maintenance intervals for subsequent years. Without appropriate maintenance a BMP can exceed its storage capacity which can negatively affect its continued performance in removing and retaining captured pollutants.

System Diagrams:

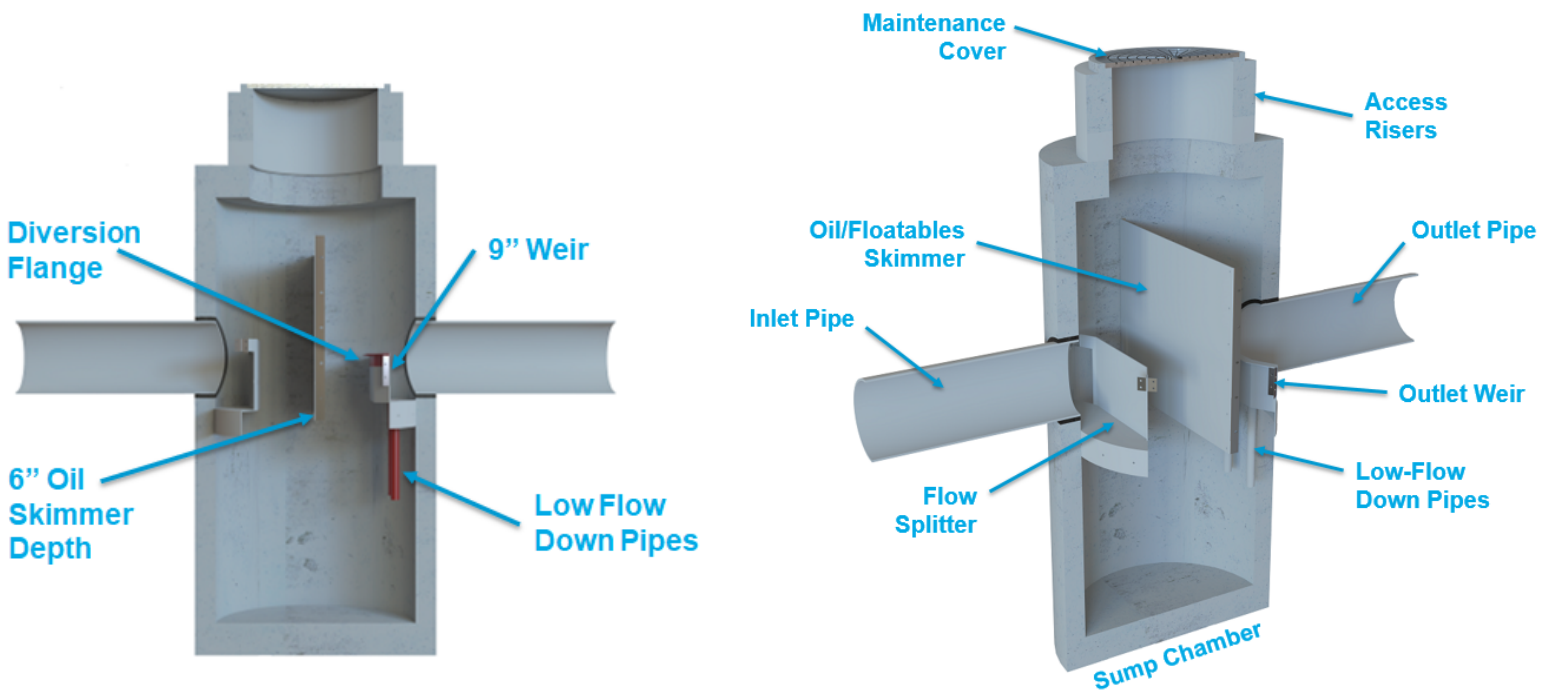

Inspection Equipment

Following is a list of equipment to allow for simple and effective inspection of the SciCloneX™ Separator:

- Bio Clean Environmental Inspection Form (contained within this manual).
- Flashlight.
- Manhole hook or appropriate tools to remove access hatches and covers.
- Appropriate traffic control signage and procedures.
- Measuring pole and/or tape measure.
- Protective clothing and eye protection.
- Note: entering a confined space requires appropriate safety and certification. It is generally not required for routine inspections or maintenance of the system.

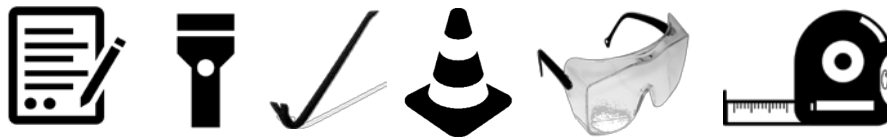

Inspection Steps

The core to any successful stormwater BMP maintenance program is routine inspections. The inspection steps required on the SciCloneX™ Separator are quick and easy. As mentioned above the first year should be seen as the maintenance interval establishment phase. During the first year more frequent inspections should occur in order to gather loading data and maintenance requirements for that specific site. This information can be used to establish a base for long-term inspection and maintenance interval requirements.

The SciCloneX™ Separator can be inspected through visual observation without entry into the system. All necessary pre-inspection steps must be carried out before inspection occurs, especially traffic control and other safety measures to protect the inspector and near-by pedestrians from any dangers associated with an open access hatch or manhole. Once these access covers have been safely opened the inspection process can proceed:

- Prepare the inspection form by writing in the necessary information including project name, location, date & time, unit number and other info (see inspection form).
- Observe the inside of the system through the access hatches. If minimal light is available and vision into the unit is impaired utilize a flashlight to see inside the system.
- Look for any out of the ordinary obstructions in the inflow pipe, sump chamber, or outflow pipe. Write down any observations on the inspection form.
- Through observation, and/or digital photographs, estimate the amount of floatable debris accumulated on the influent side of the oil/floatables skimmer. Record this information on the inspection form. Next utilizing a tape measure or measuring stick estimate the amount of sediment accumulated in the sump. Record this depth on the inspection form.

- Finalize inspection report for analysis by the maintenance manager to determine if maintenance is required.

Maintenance Indicators

Based upon observations made during inspection, maintenance of the system may be required based on the following indicators:

- Missing or damaged internal components.
- Obstructions in the system or its inlet or outlet.
- Excessive accumulation of floatables in the sump chambers in which the length and width of the chambers behind oil/floatables skimmer is fully impacted extending down more than 9”.
- Excessive accumulation of sediment in the sump chamber of more than 18” in depth.

Maintenance Equipment

It is recommended that a vacuum truck be utilized to minimize the time required to maintain the SciCloneX™ Separator :

- Bio Clean Environmental Maintenance Form (contained in O&M Manual).
- Flashlight.
- Manhole hook or appropriate tools to access hatches and covers.
- Appropriate traffic control signage and procedures.
- Protective clothing and eye protection.
- Note: entering a confined space requires appropriate safety and certification. It is generally not required for routine maintenance of the system.
- Vacuum truck (with pressure washer attachment preferred).

Maintenance Procedures

It is recommended that maintenance occurs at least three days after the most recent rain event to allow for drain down of any associated upstream detention systems. Maintaining the system while flows are still entering it will increase the time and complexity required for maintenance. Cleaning of the sump chamber can be performed from finish surface without entry into the vault utilizing a vacuum truck. Once all safety measures have been set up cleaning of the sump chamber can proceed as followed:

- Remove all access hatches (requires traffic control and safety measures to be completed prior).
- Using an extension on a vacuum truck position the hose over the opened access hatch and lower into the center of the sump chamber on the inlet side of the oil/floatables skimmer.

Remove all floating debris, standing water and sediment from the sump chamber. Access to the bottom of the sump chamber is unimpeded. The vac hose can be moved from side-to-side to fully remove sediments at the corners. A power washer can be used to assist if sediments have become hardened and stuck to the walls or the floor of the chamber. Repeat the same procedure on the effluent side of the oil/floatables skimmer to remove any remaining sediment. This completes the maintenance procedure required on the sump chamber and the SciCloneX™ Separator.

- The last step is to close up and replace all access hatches and remove all traffic control.
- All removed debris and pollutants shall be disposed of following local and state requirements.
- Disposal requirements for recovered pollutants may vary depending on local guidelines. In most areas the sediment, once dewatered, can be disposed of in a sanitary landfill. It is not anticipated that the sediment would be classified as hazardous waste.
- In the case of damaged components, replacement parts can be ordered by the manufacturer.

Maintenance Sequence



Remove Access Hatches Set Up Vacuum Truck to Clean the Sump Chamber.

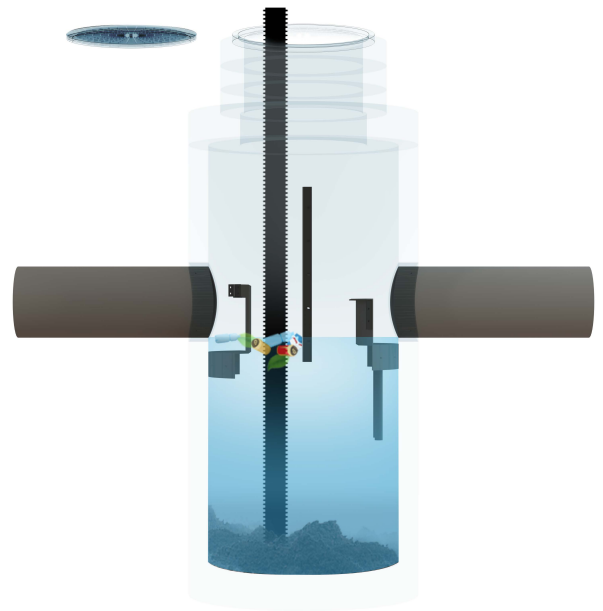

Insert Vacuum Hose On the Inlet Side of the Oil/Floatables Skimmer and Vacuum Out All Trash, Sediment and Standing Water.

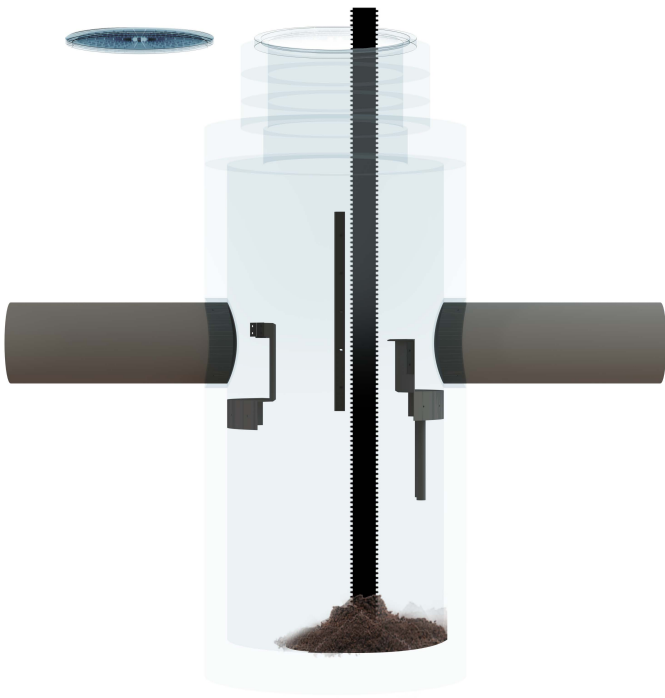

Insert Vacuum Hose On the Outlet Side of the Oil/Floatables Skimmer and Vacuum Out Any Remaining Sediment.



Replace Access Hatches and Remove Traffic Control and Safety Equipment.

For Maintenance Services or Information Please Contact Us At:
760-433-7640
Or Email: stormwater@forterrabp.com

Inspection and Maintenance Report Bio Clean SciCloneX™ Separator

Project Name _____

For Office Use Only

Project Address _____ (city) (Zip Code)

(Reviewed By)

Owner / Management Company _____

(Date)
Office personnel to complete section to the left.

Contact _____ Phone () -

Inspector Name _____ Date ____ / ____ / _____ Time _____ AM / PM

Type of Inspection Routine Follow Up Complaint Stor Storm Event in Last 72-hours? No Yes

Weather Condition _____ Additional Notes _____

Site Map #	GPS Coordinates of Vault	Model #	Oils and Floatables Accumulation on Inlet Side of Oil/Floatables Skimmers (lbs)	Sediment Accumulation In Sump Chamber (lbs) & Depth (inches)	Structural Notes	Operational Per Manufactures' Specifications (If not, why?)
	Lat: _____ Long: _____					
	Lat: _____ Long: _____					
	Lat: _____ Long: _____					

Comments: _____

