

ORDINANCE NO. BL2024-\_\_\_\_\_

---

The Metropolitan Government of  
Nashville and Davidson County

---

An ordinance declaring surplus certain real property and authorizing the Metropolitan Government's execution and delivery of a master development agreement and ground lease agreements related thereto, an amended and restated site coordination agreement, a campus operations and use agreement, a declaration, and other documents and agreements relating to the development of a portion of the east bank stadium campus, Proposal No. 2024M-009AG-001).

---

Adopted \_\_\_\_\_, 2024

Ordinance No. BL2024-\_\_\_\_\_

An ordinance declaring surplus certain real property and authorizing the Metropolitan Government's execution and delivery of a master development agreement and ground lease agreements related thereto, an amended and restated site coordination agreement, a campus operations and use agreement, a declaration, and other documents and agreements relating to the development of a portion of the east bank stadium campus, (Proposal No. 2024M-009AG-001).

WHEREAS, The Sports Authority of The Metropolitan Government of Nashville and Davidson County (the "Sports Authority") previously owned approximately 95 acres of land on the east bank of the Cumberland River in Nashville, Tennessee, as more particularly described in Exhibit A (the "Campus"), on which is located a multi-purpose outdoor stadium currently known as Nissan Stadium (the "Existing Stadium"), which is owned by the Sports Authority and leased to Cumberland Stadium, Inc., a Delaware corporation and the successor to Cumberland Stadium, L.P. ("Cumberland"), an affiliate of the National Football League's Tennessee Titans, operating as Tennessee Football, LLC (the "Team"), pursuant to that certain Stadium Lease, dated as of May 14, 1996, as amended, between the Sports Authority, as lessor, and Cumberland, as lessee (the "Existing Lease"); and

WHEREAS, the Metropolitan County Council (the "Metropolitan Council") of The Metropolitan Government of Nashville and Davidson County (the "Metropolitan Government") enacted Metropolitan Council Ordinance BL2023-1741 on April 25, 2023, approving, among other things:

(i) the construction of a new enclosed stadium (the "New Stadium") by the Sports Authority on the Campus for use by Tennessee Stadium, LLC, an affiliate of the Team ("StadCo") and (ii) the demolition of the Existing Stadium; and

(ii) the acquisition by the Metropolitan Government of a fee simple interest in the land comprising the Campus, with the exception of site of the Existing Stadium; and

(iii) the execution and delivery of an option agreement between the Metropolitan Government and the Sports Authority (the "Option Agreement") whereby, upon the demolition of the Existing Stadium, the Metropolitan Government has the right to purchase for \$100 the Sports Authority's fee interest in the site of the Existing Stadium; and

(iii) the execution and delivery of a site coordination agreement among the Metropolitan Government, the Sports Authority and StadCo (the "Site Coordination Agreement") governing the relative rights of the parties with respect to the construction and operation of the New Stadium and the development and operation of the Campus; and

WHEREAS, pursuant to Metropolitan Council Ordinance BL2023-1741, the Metropolitan Government has acquired a fee simple interest in the land comprising the Campus, with the exception of the site of the Existing Stadium, and entered into the Option Agreement and the Site Coordination Agreement; and

WHEREAS, in anticipation of the redevelopment of the 338 acres of public and private land located along the Cumberland River and immediately adjacent to the Metropolitan Government's downtown core (the "East Bank"), within which the Campus is located, the Metropolitan Government's Planning Department, in collaboration with expert consultants, undertook extensive technical analysis, urban design inquiry, and robust community outreach to shape a vision, Imagine East Bank, to better ensure high-quality public and private development on the East Bank; and

WHEREAS, the Metropolitan Council adopted Metropolitan Council Resolution RS2022-1828 on November 15, 2022, approving the solicitation, by a request for qualifications and proposals process by the Division of Purchases and the Planning Department, of a master developer to develop that portion of the Campus depicted on Exhibit A (the “Initial Development Area”) in a manner consistent with Imagine East Bank; and

WHEREAS, the Division of Purchases and the Planning Department have completed the request for qualifications and proposals process approved by the Metropolitan Council and recommended approval of The Fallon Company LLC, or one or more of its affiliates (“Fallon”) as master developer of the Initial Development Area; and

WHEREAS, the Site Coordination Agreement contemplates the completion of an open-air plaza to provide necessary ingress and agrees to the New Stadium and through the Campus, and the Metropolitan Government, Fallon and StadCo have determined that (i) such plaza (the “Second Street Plaza”) should be located as depicted on Exhibit A, and (ii) StadCo should bear the costs of completing the design and construction of the Second Street Plaza as a part of the costs of completing the New Stadium in accordance with the terms of the stadium development agreement related thereto; and

WHEREAS, the design of the New Stadium has been completed, and the Metropolitan Council wishes to memorialize the right of certain public access areas and loading egress areas related to the New Stadium to occupy portions of adjacent parcels within the Campus; and

WHEREAS, on Thursday, February 29, 2024, a community meeting was conducted at the Fifteenth Avenue Baptist Church, 1203 9th Avenue North, Nashville, Tennessee 37208, regarding the proposed lease by the Metropolitan Government of the Initial Development Area to Fallon as required by Metropolitan Code of Laws § 2.24.230; and

WHEREAS, the Metropolitan Council has been presented with the form of master development agreement between the Metropolitan Government and Fallon attached hereto as Exhibit B (the “Master Development Agreement”), which provides the terms and conditions for Fallon’s development of the Initial Development Area; and

WHEREAS, the Master Development Agreement contemplates that parcels of property within the Initial Development Area will be leased by the Metropolitan Government to Fallon prior to Fallon’s development thereof, pursuant to long-term ground lease agreements in the form exhibited to the Master Development Agreement (“Ground Lease Agreements”); and

WHEREAS, the Metropolitan Council has been presented with the form of a Campus Operations and Use Agreement among the Metropolitan Government, Fallon and StadCo attached hereto as Exhibit C, which more fully delineates the relative rights and responsibilities for the parties relative to the development and operation of the New Stadium and the Initial Development Area (the “Campus Operations Agreement”); and

WHEREAS, the Metropolitan Government, Fallon and StadCo have determined that it is necessary and appropriate for the Metropolitan Government to make and record a declaration of certain covenants, conditions and restrictions applicable to the Second Street Plaza and certain public access areas and loading egress areas related to the New Stadium to provide for the rights and responsibilities of the various parties thereto, and the Metropolitan Council has been presented with the form of such declaration attached hereto as Exhibit D (the “Declaration”); and

WHEREAS, the Site Coordination Agreement contemplated the future execution and delivery of a parking operations agreement to govern the operations of parking facilities that are reserved for StadCo’s use during events at the New Stadium, and the Metropolitan Council has been presented with the form of a Stadium Parking Facilities Development, Operations and Use Agreement attached hereto as Exhibit E (the “Parking Agreement”); and

WHEREAS, the Metropolitan Council has been presented with the form of an amended and restated site coordination agreement between the Metropolitan Government and StadCo attached hereto as Exhibit F (the “Amended and Restated Site Coordination Agreement”), which amends and restates the Site Coordination Agreement to remove the Sports Authority as a party thereto and to more precisely define the relative rights of the parties thereto in light of the terms of the Master Development Agreement, the Campus Operations Agreement, the Declaration and the Parking Agreement.

NOW, THEREFORE, BE IT ENACTED BY THE METROPOLITAN COUNTY COUNCIL OF THE METROPOLITAN GOVERNMENT OF NASHVILLE AND DAVIDSON COUNTY:

Section 1. The Metropolitan Council declares the Initial Development Area, owned in fee simple by the Metropolitan Government, to be surplus.

Section 2. The form, terms and provisions of the Master Development Agreement attached hereto as Exhibit B are hereby approved, and the Metropolitan Mayor, Metropolitan Clerk, and Director of Law of the Metropolitan Government are hereby authorized, empowered and directed to execute and deliver the Master Development Agreement in the name and on behalf of the Metropolitan Government in substantially the form attached hereto as Exhibit B, with such changes and additions thereto and omissions therefrom as the Metropolitan Mayor shall approve as necessary or appropriate, such execution and delivery to be conclusive evidence of such approval; provided that such changes, additions and omissions do not have any material adverse effect on the terms of the Master Development Agreement attached hereto as Exhibit B. From and after the execution and delivery of the Master Development Agreement, the Metropolitan Mayor and such employees of the Metropolitan Government as he or she may designate from time to time, or any of them, are hereby authorized, empowered and directed to do all such acts and things and to execute all such documents as may be necessary to carry out and comply with the provisions of the Master Development Agreement as so executed, including without limitation providing any and all approvals, consents and waivers required thereby, and entering into such amendments thereto that do not have any material adverse effect on the terms of the Master Development Agreement attached hereto as Exhibit B.

Section 3. The form, terms and provisions of the Ground Lease Agreements attached hereto as part of Exhibit B are hereby approved, and the Metropolitan Mayor, Metropolitan Clerk, and Director of Law of the Metropolitan Government are hereby authorized, empowered and directed to execute and deliver the Ground Lease Agreements from time to time in the manner contemplated by the Master Development Agreement, in the name and on behalf of the Metropolitan Government in substantially the form attached hereto as part of Exhibit B, with such changes and additions thereto and omissions therefrom as the Metropolitan Mayor shall approve as necessary or appropriate, such execution and delivery to be conclusive evidence of such approval; provided that such changes, additions and omissions do not have any material adverse effect on the terms of the Ground Lease Agreements attached hereto as part of Exhibit B. From and after the execution and delivery of each Ground Lease Agreement, the Metropolitan Mayor and such employees of the Metropolitan Government as he or she may designate from time to time, or any of them, are hereby authorized, empowered and directed to do all such acts and things and to execute all such documents as may be necessary to carry out and comply with the provisions of such Ground Lease Agreement as so executed, including without limitation providing any and all approvals, consents and waivers required thereby, and entering into such amendments thereto that do not have any material adverse effect on the terms of the form of Ground Lease Agreement attached hereto as Exhibit B.

Section 4. The form, terms and provisions of the Campus Operations Agreement attached hereto as Exhibit C are hereby approved, and the Metropolitan Mayor, Metropolitan Clerk, and Director of Law of the Metropolitan Government are hereby authorized, empowered and directed to execute and deliver the Campus Operations Agreement in the name and on behalf of the Metropolitan Government in substantially the form attached hereto as Exhibit C, with such changes and additions thereto and omissions therefrom as the Metropolitan Mayor shall approve as necessary or appropriate, such execution and delivery to be conclusive evidence of such approval; provided that such changes, additions and omissions do not have any material adverse effect on the terms of the Campus Operations Agreement attached hereto as Exhibit C. From and after the execution and delivery of the Campus Operations Agreement, the Metropolitan Mayor and such employees of the Metropolitan Government as he or she may designate from time to time, or any of them, are hereby authorized, empowered and directed to do all such acts and things and to execute all such documents as may be necessary to carry out and comply with the provisions of the Campus Operations Agreement as so executed, including without limitation providing any and all approvals, consents and waivers required thereby, and entering into such amendments thereto that do not have any material adverse effect on the terms of the Campus Operations Agreement attached hereto as Exhibit C.

Section 5. The form, terms and provisions of the Declaration attached hereto as Exhibit D are hereby approved, and the Metropolitan Mayor, Metropolitan Clerk, and Director of Law of the Metropolitan Government are hereby authorized, empowered and directed to execute and record the Declaration, or a memorandum thereof, in the name and on behalf of the Metropolitan Government in substantially the form attached hereto as Exhibit D, with such changes and additions thereto and omissions therefrom as the Metropolitan Mayor shall approve as necessary or appropriate, such execution and recordation to be conclusive evidence of such approval; provided that such changes, additions and omissions do not have any material adverse effect on the terms of the Declaration attached hereto as Exhibit D. From and after the execution and recordation of the Declaration, the Metropolitan Mayor and such employees of the Metropolitan Government as he or she may designate from time to time, or any of them, are hereby authorized, empowered and directed to do all such acts and things and to execute all such documents as may be necessary to carry out and comply with the provisions of the Declaration as so executed, including without limitation providing any and all approvals, consents and waivers required thereby, and entering into such amendments thereto that do not have any material adverse effect on the terms of the Declaration attached hereto as Exhibit D.

Section 6. The form, terms and provisions of the Parking Agreement attached hereto as Exhibit E are hereby approved, and the Metropolitan Mayor, Metropolitan Clerk, and Director of Law of the Metropolitan Government are hereby authorized, empowered and directed to execute and deliver the Parking Agreement in the name and on behalf of the Metropolitan Government in substantially the form attached hereto as Exhibit E, with such changes and additions thereto and omissions therefrom as the Metropolitan Mayor shall approve as necessary or appropriate, such execution and delivery to be conclusive evidence of such approval; provided that such changes, additions and omissions do not have any material adverse effect on the terms of the Parking Agreement attached hereto as Exhibit E. From and after the execution and delivery of the Parking Agreement, the Metropolitan Mayor and such employees of the Metropolitan Government as he or she may designate from time to time, or any of them, are hereby authorized, empowered and directed to do all such acts and things and to execute all such documents as may be necessary to carry out and comply with the provisions of the Parking Agreement as so executed, including without limitation providing any and all approvals, consents and waivers required thereby, and entering into such amendments thereto that do not have any material adverse effect on the terms of the Parking Agreement attached hereto as Exhibit E.

Section 7. The form, terms and provisions of the Amended and Restated Site Coordination Agreement attached hereto as Exhibit F are hereby approved, and the Metropolitan Mayor, Metropolitan Clerk, and Director of Law of the Metropolitan Government are hereby authorized, empowered and directed to execute and deliver the Amended and Restated Site Coordination Agreement in the name and on behalf of the Metropolitan Government in substantially the form attached hereto as Exhibit F, with such changes and additions thereto and omissions therefrom as the Metropolitan Mayor shall approve as necessary or appropriate, such execution and delivery to be conclusive evidence of such approval; provided that such changes, additions and omissions do not have any material adverse effect on the terms of the Amended and Restated Site Coordination Agreement attached hereto as Exhibit F. From and after the execution and delivery of the Amended and Restated Site Coordination Agreement, the Metropolitan Mayor and such employees of the Metropolitan Government as he or she may designate from time to time, or any of them, are hereby authorized, empowered and directed to do all such acts and things and to execute all such documents as may be necessary to carry out and comply with the provisions of the Amended and Restated Site Coordination Agreement as so executed, including without limitation providing any and all approvals, consents and waivers required thereby, and entering into such amendments thereto that do not have any material adverse effect on the terms of the Amended and Restated Site Coordination Agreement attached hereto as Exhibit F.

Section 8. All acts and doings of the Metropolitan Mayor, Metropolitan Clerk, Director of Finance, Director of Law and any other officer of the Metropolitan Government which are in conformity with the purposes and intent of this Ordinance shall be, and the same hereby are in all respects, approved and confirmed as may be necessary or appropriate in order for the Metropolitan Government to comply with the terms of the documents and agreements contemplated herein, including but not limited to the Master Development Agreement, the Ground Lease Agreements, the Campus Operations Agreement, the Declaration, the Parking Agreement, and the Amended and Restated Site Coordination Agreement.

Section 9. This Ordinance and any of the documents approved by this Ordinance may be amended by resolution adopted by the Metropolitan Council receiving a majority of the votes to which the Metropolitan Council is entitled.

Section 10. All ordinances in conflict or inconsistent herewith are hereby repealed insofar as any conflict or inconsistency exists.

Section 11. This Ordinance shall take effect from and after its adoption, the welfare of the Metropolitan Government requiring it.

APPROVED AS TO AVAILABILITY OF FUNDS BY:



Kevin Crumbo  
Director of Finance

APPROVED AS TO FORM AND LEGALITY:

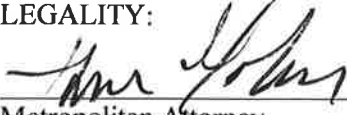

Metropolitan Attorney

INTRODUCED BY:



MEMBERS OF COUNCIL

**EXHIBIT A**

**DEPICTION OF CAMPUS, INITIAL DEVELOPMENT AREA AND SECOND STREET PLAZA**

(attached)



**EXHIBIT B**

**FORM OF MASTER DEVELOPMENT AGREEMENT AND GROUND LEASE AGREEMENT**

(attached)

**EXHIBIT C**

**FORM OF CAMPUS OPERATIONS AGREEMENT**

(attached)

**EXHIBIT D**

**FORM OF DECLARATION**

(attached)

**EXHIBIT E**

**FORM OF PARKING AGREEMENT**

(attached)

EXHIBIT B-1  
IDA LAND



DRAFT

IDA LAND

DRAFT

MASTER DEVELOPMENT AGREEMENT

between

THE METROPOLITAN GOVERNMENT OF NASHVILLE AND DAVIDSON COUNTY

and

TFC NASHVILLE DEVELOPMENT LLC,

as Developer

Dated as of [\_\_\_\_\_], 2024

**TABLE OF CONTENTS**

	<b><u>Page</u></b>
1. DEFINITIONS.....	6
2. AGREEMENT TO DEVELOP PREMISES AND TO ENTER INTO GROUND LEASES .	19
2.1 Development of Premises .....	19
2.2 Agreement Regarding Ground Leases .....	19
2.3 Execution of Ground Leases.....	19
2.4 Cooperation.....	20
2.5 Representations of Developer .....	20
2.6 Representations and Covenants of Owner .....	22
2.7 Interim Covenants of Owner.....	24
3. PREMISES .....	25
3.1 Description .....	25
3.2 Infrastructure.....	25
3.3 Condition.....	26
3.4 TPAC Project Improvements; Parcels A and B.....	27
3.5 Title/Survey.....	27
3.6 Site Investigations .....	31
3.7 Environmental Diligence .....	32
3.8 Stadium Parking Spaces.....	32
4. DEVELOPER’S PAYMENTS .....	32
4.1 Certain Ground Lease Payments.....	32
5. THE PROJECT; PROJECT PLANS; CONSTRUCTION OF IMPROVEMENTS.....	32
5.1 The Project .....	32
5.2 Project Plans.....	33
5.3 The Improvements .....	35
5.4 Project Approvals.....	35
5.5 Project Development Budget .....	36
5.6 Development Schedule; Diligent Efforts .....	37
5.7 Construction Management Plan.....	39
5.8 Status of Subject Project .....	39
5.9 Construction Management Agreement .....	40
5.10 Coordination of Improvements with Third Party Construction.....	40
5.11 Developer’s General Contractors and Architects .....	40

- 5.12 No Obligation of Owner .....41
- 5.13 Project Implementation.....41
- 5.14 Failure to Meet Development Milestones.....41
- 6. CLOSING OF GROUND LEASE TRANSACTION .....41
  - 6.1 Place and Time of Closing.....41
  - 6.2 Conditions Precedent to Owner’s Obligations.....42
  - 6.3 Conditions Precedent to Developer’s Obligations.....43
  - 6.4 Development Milestone Conditions. ....45
  - 6.5 Waiver of Conditions.....46
- 7. RESTRICTIONS ON ASSIGNMENT AND SUBLEASE.....46
  - 7.1 Assignability .....46
  - 7.2 Prohibited Transfers.....47
- 8. INDEMNIFICATION AND INSURANCE.....49
  - 8.1 Indemnification.....49
  - 8.2 Required Insurance .....51
- 9. ENVIRONMENTAL MATTERS .....51
  - 9.1 Environmental Due Diligence.....51
- 10. EMINENT DOMAIN.....53
  - 10.1 Award Proceeds/Termination .....53
- 11. DEFAULT AND TERMINATION.....53
  - 11.1 Default.....53
  - 11.2 Termination of Agreement.....55
  - 11.3 Remedies.....56
- 12. MISCELLANEOUS .....56
  - 12.1 Applicable Law; Waiver, Interpretation .....57
  - 12.2 No Waiver.....57
  - 12.3 Notices .....57
  - 12.4 Partial Invalidity.....59
  - 12.5 Entire Agreement; Amendment .....59
  - 12.6 Compliance with Laws .....59
  - 12.7 Relationship of the Parties .....59
  - 12.8 Confidentiality .....59
  - 12.9 Time of the Essence .....62
  - 12.10 Intentionally Omitted.....62



12.11 Remedies Cumulative .....	62
12.12 Approval .....	62
12.13 Bind and Inure.....	63
12.14 Limitation of Liability.....	63
12.15 No Advertisement .....	64
12.16 When Agreement Becomes Binding; Counterparts; Electronic Signatures .....	64
12.17 Survival.....	64
12.18 Intentionally Omitted.....	64
12.19 No Recording .....	64
12.20 Standard Metro Provisions.....	64
12.21 Incorporation of Exhibits and Schedules .....	64
13. Limited Guaranty From Fallon .....	64

**List of Schedules**

Schedule 1.A	Expedited Dispute Resolution Procedure
Schedule 1.B	Senior Executives
Schedule 3.5.5	Required Endorsements
Schedule 4.1.1.1	Base Value Per Rentable Square Foot
Schedule 4.1.1.2	Rent Calculation Methodology
Schedule 5.1.1.1	Provisions Relating to Residential Project Component
Schedule 5.1.1.2	Provisions Relating to Office Project Component
Schedule 5.1.1.3	Provisions Relating to Hotel Project Component
Schedule 5.13.4	Diversity, Equity, and Inclusion Commitments

**List of Exhibits**

Exhibit A	Campus
Exhibit B-1	Depiction of IDA Land
Exhibit B-2	Depiction of Premises
Exhibit B-3	Legal Description of the Premises
Exhibit B-4	Developer Pedestrian Bridge Extension Component
Exhibit B-5	TPAC Pedestrian Bridge Extension Component
Exhibit B-6	Second Street Plaza
Exhibit B-7	TPAC Street Improvements
Exhibit C-1	Form of Ground Lease
Exhibit C-2	Form of Memorandum of Ground Lease
Exhibit D	Scope of Work Document
Exhibit E	Preliminary Development Schedule
Exhibit F	Required Insurance
Exhibit G	Form of Completion Guaranty

Exhibit H      Development Master Plan  
Exhibit I      Form of Memorandum of Agreement

**MASTER DEVELOPMENT AGREEMENT**  
(East Bank Redevelopment Project – Initial Development Area)

This MASTER DEVELOPMENT AGREEMENT (this “Agreement”) is entered into as of this [\_\_\_\_] day of [\_\_\_\_\_], 2024 (the “Effective Date”) by and between THE METROPOLITAN GOVERNMENT OF NASHVILLE AND DAVIDSON COUNTY, whose address is Metropolitan Courthouse, 1 Public Square, Nashville, Tennessee 37201 (“Owner”), and TFC NASHVILLE DEVELOPMENT LLC, a Delaware limited liability company (hereinafter with its successors and assigns, “Developer”), whose address is 1222 Demonbreun St., Suite 1210, Nashville, Tennessee 37203. Owner and Developer may be referred to herein individually as a “Party”, and collectively as the “Parties”. THE FALLON COMPANY LLC, a Massachusetts limited liability company (“Fallon”) joins in this Agreement for the limited purpose of agreeing to Section 13 below.

**BACKGROUND**

- A. Owner or an instrumentality thereof is the record fee owner of certain real property in the East Bank area of the City of Nashville, comprising approximately 95 acres of land as described on **Exhibit A** (the “Campus”). The Campus currently houses an existing multi-purpose outdoor stadium known as Nissan Stadium (the “Existing Stadium”) on approximately 32 acres of land owned by The Sports Authority of the Metropolitan Government of Nashville and Davidson County (the “Sports Authority”), an instrumentality of Owner, which is in turn ground leased by Cumberland Stadium, Inc. Owner and the Sports Authority have entered into certain agreements with Tennessee Stadium, LLC (“StadCo”), providing for the lease and development of an approximately 21-acre site located on the Campus immediately east of the Existing Stadium (the “Stadium Site”) to construct a new, first-class, state-of-the-art, enclosed venue (the “Stadium”) for professional football and other sporting, entertainment, cultural and civic events (the “Stadium Project”).
- B. Owner initiated a Request for Quotation 324254-3, East Bank Central Waterfront Initial Development Area (the “RFQ”) in order to find a master developer for those portions of the Campus identified on **Exhibit B-1** comprising approximately 30 acres of land (the “IDA Land”); in response to the RFQ, Developer has submitted a proposal to serve as the master developer for the IDA Land; and Owner has selected Developer to serve as the master developer for the IDA Land.
- C. Owner desires to enter into long-term ground leases with one or more Developer Parties (as hereinafter defined) with respect to the IDA Land, and Developer Parties desire to acquire long-term ground leasehold interests in the IDA Land pursuant to one or more Ground Leases, subject to and in accordance with the terms and provisions of this Agreement.
- D. Developer Parties propose to develop, construct upon, improve, and operate on the Premises (as hereinafter defined) a phased multi-building, mixed-use project

containing the following preliminary uses subject to and in accordance with the terms of this Agreement: (1) residential uses (the “Residential Project Component”), (2) hotel uses (the “Hotel Project Component”), (3) retail uses (the “Retail Component”), (4) office uses (the “Office Project Component”), and (5) public realm uses, including the Pedestrian Bridge Extension (a portion of which will be constructed by TPAC, as more fully described herein) (the “Public Realm Component”), all of which are to be constructed substantially in accordance with, to the extent applicable, each of the following: (i) the Development Master Plan, (ii) the Development Budget for each Ground Lease Parcel, (iii) the Final Plans for each Ground Lease Parcel, (iv) the Construction Management Plan for the Ground Lease Parcel, (v) the Approvals, (vi) all applicable Laws, and (vii) the terms and conditions of this Agreement (collectively, the “Project”).

## AGREEMENT

Therefore, in consideration of the foregoing and the mutual covenants and agreements contained herein, Owner and Developer agree as follows:

### 1. **DEFINITIONS**

The following capitalized terms used in this Agreement shall have the meaning set forth or referenced in this Section:

Affected Ground Lease Parcel: as defined in Section 3.5.2.2.

Affiliate: as to any Person, any other Person that, directly or indirectly, is in Control of, Controlled by, or under common Control with, such Person.

Affordable Developer: Holladay Ventures or any Affiliate thereof, or any other developer selected by Developer with Owner’s Reasonable Approval to develop any Income Restricted Residential Building.

Agreement: this Master Development Agreement (including the Schedules and Exhibits annexed hereto), as the same may hereafter be amended or modified from time to time.

Anticipated Stadium Opening Date: the date on which StadCo has scheduled for the Metropolitan Government of Nashville and Davidson County to issue the temporary certificate of occupancy allowing the use and occupancy of the Stadium, which as of the Effective Date is April 1, 2027.

Appropriate Owner Staff: means the Metropolitan Mayor or such employees of the Metropolitan Government as he or she may designate from time to time.

Approval(s): collectively, all environmental, land use, building, construction, occupancy and related permits, and any other permits, licenses and approvals required by applicable federal, state or local statutes, laws, rules, regulations, codes, ordinances, directives, orders or decrees (whether now existing or hereafter enacted, promulgated or issued), as the same may be amended from time to time, which are necessary to enable the construction of the Project, or to enable

Developer to perform the Developer Infrastructure Work, or to enable Developer to use the Improvements or any portion thereof.

Approval Authority(ies): any governmental authority, agency or board or other public party having jurisdiction over the development of the Project or the Developer Infrastructure Work or the granting of any of the Approvals or any subcommittee or other subgroup or any member or members thereof.

Approval Matter: as defined in Section 12.12.2.1.

Approvals Efforts: any and all (1) public hearings or meetings relative to the Project with or involving an Approval Authority, and/or (2) private discussions or meetings relative to the Project with an Approval Authority or an elected official, (3) any Approvals Filings.

Approvals Filing(s): collectively, all applications and submissions (including, without limitation, all narrative descriptions, plans, specifications, drawings, renderings, reports, studies and analyses filed or submitted in connection with any such application or submission), together with all amendments or modifications thereto, required by applicable Laws, order, code, rule or regulation, to be filed or made by Developer and/or Owner, whether as the proponent or as a co-proponent (as the case may be), to any Approval Authority in connection with obtaining any Approval for the Project.

Approved Control Persons: as of any applicable date of determination, any of (i) Joseph F. Fallon, Michael J. Fallon or Brian M. Awe or (ii) any other Person proposed by Developer and approved by Owner in its sole discretion.

Development Master Plan: as defined in Section 5.2.1.

Architect: as defined in Section 5.11.1.

Business Day: each day of the week, Monday through Friday, excluding holidays that are officially observed in the State of Tennessee.

Campus: as defined in the Background recitals.

Campus Operations Agreement: means that certain Campus Operations and Use Agreement among Owner, Developer, and StadCo, dated as of \_\_\_\_\_, 2024.

Claims: means all losses, damages, charges, liabilities (direct or indirect), claims, demands, costs, expenses (including, without limitation, reasonable attorneys' fees and expenses) and suits or other causes of action of any nature whatsoever.

Closing: with respect to each Ground Lease Parcel, the execution and delivery of (A) a Ground Lease with respect to such Ground Lease Parcel and (B) all documents, materials and information required pursuant to Section 6 hereof in connection with the execution of such Ground Lease.

Closing Date: as defined in Section 6.1.

Commencement of Construction: means that Developer has obtained a grading permit required to commence construction on the applicable Ground Lease Parcel, if applicable, and has either: (A) begun, or caused to begin, a continuous program of physical on-site preparation for construction (such as erecting necessary construction fencing), subject to the Approvals; or (B) entered into binding agreements or contractual obligations to undertake actual construction of the Improvements within a contracted period of time, which cannot be canceled or modified without substantial economic loss to any Developer Party.

Completion Guaranty: a guaranty of completion in substantially the same form as the form completion guaranty attached hereto as **Exhibit G**, subject to such modifications as may be requested by an Institutional Lender and approved by Owner in Owner's reasonable discretion.

Confidential Due Diligence Information: as defined in Section 9.1.2.

Construction Coordination Agreement: as defined in Section 5.9.

Construction Management Plan: as defined in Section 5.7.1.

Control: as defined in Section 7.2.2.

Developer: as defined in the Background Recitals.

Developer Closing Certificate: as defined in Section 2.5.8.

Developer Event of Default: as defined in Section 11.1.1.

Developer Indemnified Party: as defined in Section 8.1.3.1.

Developer Infrastructure Work: as defined in Section 3.2.1.

Developer Parties: Developer and its Affiliates, collectively.

Developer Party: shall mean and refer to either Developer or one or more Affiliates of Developer, as the context may require.

Developer Pedestrian Bridge Extension Component: subject to the cost allocation set forth in the Scope of Work Document, the initial construction of an extension of the Pedestrian Bridge from the eastern edge of the TPAC Pedestrian Bridge Component, and then proceeding east until ending on Parcel D, including the landing area for the Pedestrian Bridge, all as depicted on **Exhibit B-4**.

Developer Pedestrian Bridge Extension Milestone: means completion of the of the Developer Pedestrian Bridge Extension Component.

Developer Pedestrian Bridge Extension Milestone Date: means the date on which the last of the following occurs: (a) Substantial Completion (as defined in the Ground Lease) of the first building constructed on Parcel D, (b) Substantial Completion (as defined in the Ground Lease) of the first building constructed on Parcel E-1, and (c) the completion of the TPAC Pedestrian Bridge

Extension Component, subject to (x) extension for delays caused by Excusable Delay and (y) any other extension expressly provided for in this Agreement.

Development Budget: as defined in Section 5.5.1.

Development Master Plan: as defined in Section 5.2.1.

Development Milestone: the First Residential Development Milestone, the Second Residential Development Milestone, the Third Residential Development Milestone, the Developer Pedestrian Bridge Extension Milestone, the Daycare Milestone, the Hotel Project Component Milestone, and the Residential Component Milestones.

Development Milestone Conditions: as defined in Section 6.4.

Development Schedule: as defined in Section 5.6.2.

East Bank Authority: an authority or instrumentality formed by the Metropolitan Government, upon approval of the Metropolitan Council, with the reasonable input of Developer for the purposes of owing and/or administering the IDA Land.

Effective Date: as defined in the Background Recitals.

Event(s) of Default: a Developer Event of Default or an Owner Event of Default, as applicable.

Environmental Laws: collectively, all applicable federal, state or local laws, statutes, rules, regulations, codes, ordinances, directives, orders, decrees or judicial or administrative decision or policy guideline (whether now existing or hereafter enacted, promulgated or issued), respecting the protection of the environment or health and safety, and the assessment, remediation, removal or disposal of Hazardous Materials including, without limitation, those identified in the definition of "Hazardous Materials", and the regulations promulgated under each of such statutes or laws, all as amended from time to time.

Environmental MOU: the Environmental Memorandum of Understanding annexed to the Scope of Work Document as Attachment A thereto.

Environmental Report: collectively, (i) the Phase I Environmental Site Assessment Report dated March 17, 2021, prepared by Professional Service Industries, Inc. for Tennessee Football, Inc. (PSI Project Number 03581624-1), and (ii) the Report of Phase II Environmental Site Assessment prepared by Geo-Technology Associates, Inc for Tennessee Football, Inc. (GTA Project Number 31230396).

Excluded Claims: any Claims that arise from (x) the fraud, gross negligence, bad faith or willful misconduct of a Party seeking indemnification hereunder (or any of its Affiliates, agents, officers or employees), or (y) the intentional breach by such Party of this Agreement.

Excusable Delay: means the period of time, if any, that the performance of Developer's obligations under this Agreement is actually delayed or prevented by the occurrence of any of the

following events: (a) Force Majeure; (b) Owner-Caused Delay; (c) any systemic failures in capital markets, including without limitation failures or delays in capital markets in or around Nashville, Tennessee; (d) the general inability to obtain, or impracticability of obtaining (due to material increases in interest rates or fees which could not have been reasonably anticipated by Developer as of the Effective Date), debt or equity financing due to (x) temporary contraction of or upheaval in the financing markets in the United States, or (y) a material slowdown in leasing activity caused by economic forces generally, such as a recession; (e) the infeasibility or impracticability of the Subject Project due to excess inventory in the local market, temporary contraction of or upheaval in the financing markets in the United States, or a material slowdown in leasing activity caused by economic forces generally, such as a recession, (f) with respect to the any milestone involving income restricted housing, the inability to obtain typical subsidies or other customary financing notwithstanding Developer's (or its assignee's) use of commercially reasonable efforts (g) the failure of any condition precedent to Developer's obligations hereunder or to any Development Milestone, or (h) anything else outside of the reasonable control of Developer, and (in each case) as to which Developer notifies Owner in writing within one hundred twenty (120) days after the Developer becomes aware that such event has caused a delay in Developer's performance of its obligations under this agreement in accordance with the timelines set forth herein. Notwithstanding the foregoing, "Excusable Delay" shall not include economic hardship of Developer or Developer's inability to pay debts or other monetary obligations in a timely manner.

Executive Order: as defined in Section 7.2.3(ii).

Existing Stadium: as defined in the Background recitals.

Expedited Dispute Resolution Procedure: the dispute resolution procedure set for on **Schedule 1.A**.

Fallon: as defined in the Background Recitals.

Final Court Determination: determination by a final non-appealable order of a court of competent jurisdiction.

Final Plans: as defined in Section 5.2.4.

First Residential Development Milestone: Commencement of Construction of 300 residential units, which must include an Income Restricted Residential Building in accordance with **Schedule 5.1.1.1** and the core and shell of a facility capable of housing a Qualifying Day Care Facility in compliance with any state and local requirements.

Force Majeure: means act of God (including, without limitation, delays from unusual or extreme weather events, flood, earthquake, tornado, fire, disease, and the like); labor strike or work stoppage or slowdown (including failure of building inspectors to reasonably process approvals that cause work stoppage); failure or delay by any Approval Authority (including, without limitation, any failure to complete the Rezoning or delay in completion of the Rezoning ; any delays or shortages encountered in transportation, fuel, material or labor supplies; any failure of or delay in the availability of any public utility; material shortages in supplies; sabotage, acts of a public enemy, war, riot, terrorism, moratorium, or actual or threatened health emergencies (including, without limitation, epidemic, pandemic, quarantines or other restrictions related



thereto); and governmental embargo restrictions, injunctions, or delay in any inspection by any governmental authority, and (in each case) as to which Party whose performance is delayed notifies the other Party in writing within one-hundred twenty (120) days after the Party whose performance is delayed becomes aware that such event has caused a delay in its performance of its obligations under this Agreement in accordance with the timelines set forth herein).

GAAP: generally accepted accounting principles, consistently applied.

General Contractor: as defined in Section 5.11.1.

Ground Landlord: as defined in Section 6.3.11.

Ground Lease: as defined in Section 2.3.

Ground Lease Parcel: as defined in Section 2.3.

Ground Lease Parcel Project: the portion of the Project to be developed on an applicable Ground Lease Parcel as more particularly described in the applicable Ground Lease.

Ground Rent: for any Ground Lease Parcel, the Ground Rent payable in respect of such Ground Lease Parcel, as determined in accordance with Section 4.

Ground Tenant: the applicable Developer Party or applicable Affordable Developer that executes a Ground Lease for any Ground Lease Parcel pursuant to the terms of this Agreement.

Guarantor: with respect to each Ground Lease Parcel, the Person(s) designated by Developer and approved by Owner, in Owner's sole discretion, as the party(ies) that will, jointly and severally (to the extent there is more than one Person providing the Guaranty), execute and deliver a Completion Guaranty with respect to such Ground Lease Parcel Project; *provided, however,* that Developer shall be permitted to designate the following (each, a "Pre-Approved Guarantor") without the approval of Owner (but only after providing at least thirty (30) days' prior written notice to Owner and allowing Owner to inspect reasonable supporting documentation that such Person satisfies the requirements for a Pre-Approved Guarantor):

- (a) a Person that has been approved as a guarantor by an Institutional Lender providing construction financing on the applicable Ground Lease Parcel Project, on the same basis as such Persons are accepted as guarantors by such lender (including, without limitation, with respect to the joint and/or several nature of the guaranty delivered to such lender applicable to such guaranty); or
- (b) if no Person has been approved as a guarantor by an Institutional Lender providing construction financing on the applicable Ground Lease Parcel Project, either of the following (as applicable):
  - (i) other than with respect to any Income Restricted Residential Building, one or more Persons that are Controlled by one or more Approved Control Persons (subject to customary major decision and removal rights), that are not Prohibited Persons, and that, individually or in the aggregate (with all other Persons jointly and severally

liable as Guarantors for the applicable guaranteed obligations), have at the time of delivery of such Completion Guaranty and are obligated to maintain during the period such Completion Guaranty is outstanding (x) an aggregate Net Worth equal to at least 45% of the total hard costs for the Improvements to be constructed on the applicable Ground Lease Parcel, as shown on the Development Budget for such Ground Lease Parcel, and (y) aggregate Liquid Assets equal to at least (1) 10% of total hard costs for the Improvements to be constructed on the applicable Ground Lease Parcel with respect to which such total hard costs are \$150,000,000 or less, and (2) 5% of the total hard costs for the Improvements to be constructed on the applicable Ground Lease Parcel, with respect to which the total hard costs of which are in excess of \$150,000,000, as shown on the Development Budget for such Ground Lease Parcel.

- (ii) with respect to any Income Restricted Residential Component, one or more Persons that Control, are Controlled by or under common Control with the Affordable Developer, that are not Prohibited Persons and that, individually or in the aggregate (with all other Persons jointly and severally liable as Guarantors for the applicable guaranteed obligations), have at the time of delivery of such Completion Guaranty and are obligated to maintain during the period such Completion Guaranty is outstanding (x) an aggregate Net Worth equal to at least \$10,000,000, and (y) aggregate Liquid Assets equal to at least \$2,000,000.

Notwithstanding the foregoing, at any time that a Developer Event of Default exists, any Pre-Approved Guarantor must be approved by Owner in its reasonable discretion.

Hazardous Materials: collectively, all substances defined or classified as a “hazardous substance”, “hazardous material”, “hazardous waste”, “pollutant”, or otherwise denominated as a regulated or hazardous substance, waste or material, toxic or pollutant in any of the following: (i) the federal Comprehensive Environmental Response, Compensation and Liability Act of 1980; (ii) the federal Hazardous Materials Transportation Uniform Safety Act of 1990; (iii) the federal Toxic Substances Control Act; (iv) the federal Resource Conservation and Recovery Act; (v) the Tennessee Air Quality Act, T.C.A. 68-201-101 *et seq.*; (vi) the Tennessee Hazardous Waste Management Act, T.C.A. 68-212-101 *et seq.*; (vii) the Tennessee Petroleum Underground Storage Tank Act, T.C.A. 68-215-101 *et seq.*; (viii) the Tennessee Water Quality Control Act of 1977, T.C.A. 69-3-101 *et seq.*; (ix) any other federal, state or local law addressing itself to environmental contamination, waste or health and safety; or (x) any regulations promulgated under any of the foregoing; as any of the foregoing may be promulgated or amended from time to time. “Hazardous Materials” shall specifically include, but not be limited to, oil, asbestos, explosives, polychlorinated biphenyls, petroleum and petroleum-based derivatives, and urea formaldehyde.

Hotel Maximum: means the maximum number of hotels permitted to be constructed by Developer within the Project pursuant to Schedule 5.1.1.3, provided that, for avoidance of doubt, a Residential Building which includes a hotel use, shall not be considered a hotel for the purposes of this Agreement.

Hotel Project Component Milestone: Commencement of Construction of a hotel on Parcel C.

IDA Land: as defined in the Background recitals.

Improvements: as defined in Section 5.3.1.

Income Restricted Residential Component: the portion of the Residential Project Component to be constructed on each of Parcel G and Parcel A (each as depicted on **Exhibit B-1**) as a part of a Ground Lease Parcel Project, 100% of the residential units of which will be Income Restricted Units in accordance with the standards set forth on **Schedule 5.1.1.1**.

Indemnified Party: as defined in Section 8.1.3.1.

Institutional Lender(s): as defined in the Ground Lease.

James Robertson Parkway Project: the lowering to grade of the elevated portion of the roadway from Interstate Drive west to the new finished condition including an at-grade intersection at East Bank Blvd, generally as shown on the Development Master Plan.

Laws: collectively, all federal, state, or local statutes, laws, rules, regulations, codes, ordinances, directives, orders or decrees, including, without limitation, Environmental Laws, that are in effect at the relevant time.

Leasehold Title Policy: as defined in Section 6.3.1.

Lender's Project Budget Confirmation: as defined in Section 5.5.1.

Liquid Assets: any of the following: assets in the form of cash, cash equivalents, obligations of (or fully guaranteed as to principal and interest by) the United States or any agency or instrumentality thereof (provided the full faith and credit of the United States supports such obligation or guarantee), certificates of deposit issued by a commercial bank having net assets of not less than \$250 million, securities listed and traded on a recognized stock exchange or traded over the counter and listed in the National Association of Securities Dealers Automatic Quotations, and liquid debt instruments that have a readily ascertainable value and are regularly traded in a recognized financial market. "Liquid Assets" also includes the amount of any uncalled capital commitments, and capital subject to recall, required of the constituent partners or members, as applicable, of the Person with respect to which there are no unsatisfied conditions to funding such commitments or recallable capital, provided that in each case that such commitments and recallable capital are (a) unpledged, (b) from partners or members that (i) are not in breach or otherwise in default under any agreement relating to the making of such capital contributions, (ii) are not subject to a proceeding under the United States Bankruptcy Code, and (iii) have not made any public statements indicating that they do not intend to make any further capital contributions in connection with their investments generally, and (c) do not expire within thirty (30) days from the date of determination.

Memorandum of Ground Lease: as defined in Section 2.3.

Metro or Metropolitan Government: The Metropolitan Government of Nashville and Davidson County.

Metropolitan Council: The Metropolitan County Council, the legislative and governing body of the Metropolitan Government.

Net Worth: with respect to any Person as of any calculation date, (x) the total consolidated assets of such Person (exclusive of goodwill, patents, tradenames, treasury stock, and intangibles) as reflected on the balance sheets of such guarantor on a modified cash basis, if such guarantor is an individual, or in accordance with generally accepted accounting principles, consistently applied (GAAP), if such guarantor is an entity less (y) such Person's total consolidated liabilities as of such date, on a modified cash basis, if such guarantor is an individual, or in accordance with GAAP, if such guarantor is an entity.

Outside Date: means, as applicable, the Outside First Residential Development Milestone Date, Outside Second Residential Development Milestone Date, Outside Third Residential Development Milestone Date, the Outside Initial Hotel Construction Commencement Date, or the Developer Pedestrian Bridge Extension Date.

Outside First Residential Development Milestone Date: means the date which is the second anniversary of the date on which all of the applicable Development Milestone Conditions are satisfied, subject to (x) extension for delays caused by Excusable Delays and (y) any other extension expressly provided for in this Agreement or in the applicable Ground Lease.

Outside Initial Hotel Construction Commencement Date: means the date which is two (2) years from the satisfaction of all Development Milestones Conditions, subject to (x) extension for delays caused by Excusable Delays and (y) any other extension expressly provided for in this Agreement or in the applicable Ground Lease.

Outside Second Residential Development Milestone Date: means the date which is the sixth anniversary of the date on which all of the applicable Development Milestone Conditions are satisfied, subject to (x) extension for delays caused by Excusable Delays, and (y) any other extension expressly provided for in this Agreement or in the applicable Ground Lease.

Outside Third Residential Development Milestone Date: means the date which is the ninth anniversary of the date on which all of the applicable Development Milestone Conditions are satisfied, subject to (x) extension for delays caused by Excusable Delays, and (y) any other extension expressly provided for in this Agreement or in the applicable Ground Lease.

Owner: as defined in the Background Recitals.

Owner-Caused Delay: means any actual delay to the extent caused by one or more of the following: (i) any failure by Owner to perform its obligations under the Scope of Work Document on or prior to the date required therefor in the Scope of Work Document, (ii) any failure by Owner to timely pay the costs of all or any portion of the Developer Infrastructure Work for which Owner is responsible under the Scope of Work Document, (iii) any failure by Owner to perform any of its other obligations hereunder (including Owner's obligation to cooperate with obtaining Approvals pursuant to Section 5.4), (iv) any failure by an Owner Party to perform any of its obligations under a Ground Lease, (v) Owner's failure to timely respond to a Developer request for approval of any Approval Matter (including Section 12.12), (vi) Owner's failure to proceed

with a Closing on any Ground Lease Parcel despite all conditions precedent thereto as set forth in Section 6.3 having been satisfied, and (vii) if, and to the extent determined unreasonable pursuant to a Final Court Determination, Owner's unreasonable withholding, delaying or conditioning its approval of any Approval Matter in violation of Section 12.12 (except to the extent that this Agreement allows Owner to withhold its consent to Approval Matter in its sole discretion); provided, however, that "Owner-Caused Delay" does not include any of the foregoing to the extent caused by a Developer Event of Default, Force Majeure, or the gross negligence or willful misconduct of Developer or a Developer Party.

Owner Closing Certificate: as defined in Section 2.6.12.

Owner Event of Default: as defined in Section 11.1.3.

Owner Indemnified Party: as defined in Section 8.1.3.1.

Owner Parties: Owner and any Affiliate, authority or instrumentality of Owner and any other party as may now or hereafter be owned by Owner, as may be identified by written notice from Owner to Developer from time to time; and any and all of their respective officers, trustees, directors, shareholders, partners, members, managers, members of governing boards, employees, contractors, agents, representatives or Persons acting on behalf of any of them.

Owner Mandatory Cure Encumbrances: as defined in Section 3.5.3.

Owner Reasonable Approval: as defined in Section 12.12.2.1.

Owner's Title Notice: as defined in Section 3.5.1.

Parcel: any parcel of land included in the IDA Land and labeled on Exhibit B-1 as Parcel A, B, C, D, E, F or G.

Parcel A: that certain parcel of land included in the IDA Land on the north side of the Stadium, as approximately depicted as "A" on Exhibit B-1 attached hereto.

Parcel A Commencement Outside Date: means the third anniversary (which date shall not be subject to Excusable Delay) after the last of the following to occur: (a) the completion of the James Robertson Parkway Project, and (b) the completion of East Bank Boulevard from Shelby Avenue/Koreans Veterans Blvd. north to the new at-grade intersection with James Robertson Parkway generally as shown on the Development Master Plan, and (c) Developer's receipt of written notice from WeGo and Owner that WeGo is ready, willing, and able to proceed, including without limitation, providing reasonable assurance that WeGo will have sufficient financing, with development of its mobility facility project on Parcel A in a manner reasonably satisfactory to Developer.

Parcel B: that certain parcel of land included in the IDA Land on the north side of the Stadium, as approximately depicted as "B" on Exhibit B-1 attached hereto.

Parcel B Commencement Outside Date: the fourth (4th) anniversary of the Parcel B Option Vesting Date, plus a number of days equal to the lesser of (i) 180 and (ii) the number of days by which the Parcel B Option Vesting Date precedes the Parcel B Option Outside Vesting Date.

Parcel B Delivery Condition Notice: as defined in Section 3.4.3.2.

Parcel B Option: as defined in Section 3.4.3.1.

Parcel B Option Condition Precedent: means Developer's timely satisfaction, subject to Excusable Delay, of the First Residential Development Milestone, the Second Residential Development Milestone, and the Third Residential Development Milestone.

Parcel B Option Notice: as defined in Section 3.4.3.1.

Parcel B Option Outside Vesting Date: the date which is the twelfth (12<sup>th</sup>) anniversary of the satisfaction of all of the Development Milestone Conditions applicable to the Third Residential Development Milestone.

Parcel B Option Vesting Date: means the date on which Developer has satisfied the Parcel B Option Condition Precedent, provided that such date is not later than the Parcel B Option Outside Vesting Date.

Parcel C: that certain parcel of land included in the IDA Land approximately depicted as "C" on Exhibit B-1 attached hereto.

Parcel D: that certain parcel of land included in the IDA Land approximately depicted as "D" on Exhibit B-1 attached hereto.

Parcel E-1: that certain parcel of land included in the IDA Land approximately depicted as "E-1" on Exhibit B-1 attached hereto.

Parcel E-2: that certain parcel of land included in the IDA Land approximately depicted as "E-2" on Exhibit B-1 attached hereto.

Parcel F: that certain parcel of land included in the IDA Land approximately depicted as "F" on Exhibit B-1 attached hereto.

Parcel G: That certain parcel of land included in the IDA Land approximately depicted as "G" on Exhibit B-1 attached hereto.

Parcel G-2: That portion of Parcel G to be determined by Developer in accordance with the terms hereof.

Parking Agreement: means that certain Parking Development, Use and Operations Agreement between Owner and StadCo dated as of \_\_\_\_\_, 2024.

Pedestrian Bridge: means the Seigenthaler Bridge.

Pedestrian Bridge Declaration: means that certain Declaration of Easements, Restrictions and Covenants for the Pedestrian Bridge, Parcels D, E and F, East Bank, as reasonably approved by Developer and TPAC, and executed and recorded with the Register by Owner.

Pedestrian Bridge Extension: means the TPAC Pedestrian Bridge Extension Component and the Developer Pedestrian Bridge Extension Component, all as depicted on **Exhibit B-5**.

Permitted Encumbrances: as defined in Section 3.5.4.

Permitted Owner Breach: as defined in Section 2.6.12.

Person: any individual, corporation, partnership, joint venture, limited liability company, estate, trust, unincorporated association, any federal, State, county or municipal government or any bureau, department or agency thereof and any fiduciary acting in such capacity on behalf of any of the foregoing.

Plaza/Parcel B and C Declaration: means that certain Declaration of Easements, Restrictions and Covenants for the Parcel B, the Stadium Plaza, Parcel C, East Bank subject to the reasonable approval of Developer, to be executed and recorded with the Register by Owner.

Pre-Approved Guarantor: as defined in the definition of “Guarantor”.

Preliminary Development Schedule: as defined in Section 5.6.1.

Premises: the portion of the IDA Land depicted on **Exhibit B-2**, as the same shall be described in the legal description to be prepared by Developer pursuant to Section 3.1, as such legal description may be modified by Developer in accordance with the terms of Section 3.1 from time to time prior to the Closing for any Ground Lease Parcel pursuant to Section 3.1; for avoidance of doubt, the term “Premises” shall exclude Parcel B and Parcel E-2 until such time as such parcels are added to the Premises in accordance with Sections 3.4.1 and 3.4.2.

Premises Plan: as defined in Section 3.1.

Prime Rate: means the rate announced (whether or not actually charged) from time to time by Citibank, N.A., or any successor of such bank, as its base/reference rate (or the equivalent) in effect in New York City, or, if no such bank shall exist, the rate published by The Wall Street Journal (or, if The Wall Street Journal shall no longer regularly publish such rate, a domestic financial newspaper of comparable status) from time to time as the generally prevailing rate of interest charged by commercial banks on ninety (90) day unsecured loans (or if no such rate is available a replacement rate reasonably determined Developer and Owner).

Prohibited Person: as defined in Section 7.2.3.

Project: as defined in the Background recitals.

Qualifying Day Care Facility: shall mean a day care center – over 75, as described in the Metropolitan Government of Nashville and Davidson County Code of Ordinances.

Release: with respect to Hazardous Materials, shall mean any release, deposit, discharge, emission, leaking, spilling, seeping, migrating, injecting, pumping, pouring, emptying, escaping, dumping, disposing, or other movement of Hazardous Materials into the environment.

Residential Building: any building within the Project within which residential use comprises 60% or more of the rentable square feet (exclusive of independent uses, such as retail, daycare and other similar uses).

Residential Component Milestone: as defined in Schedule 5.1.1.1.

Residential Project Component: as defined in the Background recitals.

Rezoning: as defined in Section 6.3.6.

Scope of Work Document: as defined in Section 5.2.3.

Second Residential Development Milestone: Commencement of Construction of 700 residential units in the aggregate.

Second Street Plaza: that parcel of property depicted on **Exhibit B-6**, which will be owned by Metro and made available to StadCo pursuant to the terms of the Plaza/Parcel B and C Declaration.

Second Street Plaza Improvements: the improvements to the Second Street Plaza to be constructed by StadCo pursuant to the terms of the Stadium Development Agreement.

Senior Executive: as defined in **Schedule 1.B**.

Site Coordination Document(s): means each individually, and collectively, (a) that certain Amended and Restated Site Coordination Agreement between Owner and StadCo, (b) the Campus Operations Agreement, (c) the Parking Agreement, and (d) the Plaza/Parcel B and C Declaration.

StadCo: as defined in the Background Recitals.

Stadium Development Agreement: that certain Development and Funding Agreement, dated as of August 25, 2023, between the Sports Authority and StadCo, which provides the terms and conditions for the development of the Stadium Project.

Stadium Infrastructure: those infrastructure items required to be installed and constructed outside of the Stadium Site by StadCo pursuant to the Stadium Development Agreement and the Site Coordination Documents, including without limitation the construction of Second Street between Korean Veterans Boulevard and Woodland Street, including all utilities and street improvements therein and thereon, and the relocation of certain gas and wastewater lines, all as more particularly described in the Site Coordination Documents and/or the Scope of Work Document.

Stadium Parking Spaces: as defined in Section 3.7.



Stadium Project: as defined in the Background recitals.

Stadium Site: as defined in the Background recitals.

Subject Ground Lease: as defined in Section 6.2.10.1.

Subject Premises: the applicable portion of the Premises to be ground leased in accordance with any Ground Lease.

Subject Project: the applicable portion of the Project pursuant to each Parcel Ground Lease.

Survey: as defined in Section 3.5.1.

Taking: the exercise of the power of eminent domain by a competent taking authority, excluding any such Taking in connection with the Developer Infrastructure Work.

Tax Allocation Agreement: as defined in Section 3.1.

Tenant Utilities Improvements: as defined in Section 3.3.3.

Third Residential Development Milestone: Commencement of Construction of 1,250 residential units in the aggregate.

Title Commitment: as defined in Section 3.5.1.

Title Company: First American Title Insurance Company, or, with respect to an Income Restricted Residential Building, such other title company designated by the Affordable Developer that is experienced in conducting closings and issuing title policies in connection with the acquisition and financing of an affordable housing project.

TPAC: the Tennessee Performing Arts Center Management Company.

TPAC Agreements: the definitive agreement(s) between Metro and TPAC providing for the development of (i) Parcel E-2 as a performing arts center, (ii) the TPAC Pedestrian Bridge Extension Component, and (iii) the TPAC Street Improvements.

TPAC Pedestrian Bridge Extension Component: means the renovation, improvement and extension of that portion of the Pedestrian Bridge from approximately the elevator on the Campus side of the Pedestrian Bridge, and then proceeding east to the western edge of Parcel E, to and including any steps and ramps, all as depicted on **Exhibit B-5**.

TPAC Project Improvements: means those improvements to be constructed by TPAC on Parcel E in accordance with the TPAC Agreements.

TPAC Street Improvements: the improvements to consisting of those streets and roadways depicted on **Exhibit B-7**.

## 2. AGREEMENT TO DEVELOP PREMISES AND TO ENTER INTO GROUND LEASES

2.1 Development of Premises. Developer agrees to use commercially reasonable efforts to develop (or cause other Developer Parties or Affordable Developers to develop) the Premises in accordance with, and subject to the terms of, this Agreement.

2.2 Agreement Regarding Ground Lease Parcels. Except as otherwise provided in this Agreement, Owner and Developer agree to enter into Ground Leases for the Ground Lease Parcels upon and subject to the applicable terms and conditions set forth in this Agreement.

2.3 Execution of Ground Leases. Subject to the terms and conditions of this Agreement, Owner agrees to demise and lease to Developer Parties, and Developer agrees to accept and lease (or cause another Developer Party to accept and lease) from Owner, the Subject Premises, all in accordance with and subject to written long-term ground lease agreements by and between Owner and one or more Developer Parties in substantially the form attached hereto as **Exhibit C-1**, with such changes, if any, as shall be satisfactory to Owner and Developer (each, as it may be amended from time to time in accordance with its terms, a “Ground Lease” and, collectively, the “Ground Leases”). Either party may require certain revisions to the form of Ground Leases as are reasonably necessary to address facts that are specific to a particular Ground Lease Parcel (e.g., affordable housing). Additionally, Owner agrees that the form of Ground Lease is subject to reasonable comments and/or requests of the applicable Institutional Lender (and with respect to the Ground Lease for an Income Restricted Residential Building, of the investor member or partner providing equity in connection with an allocation of low-income housing tax credits) and that Owner will not unreasonably withhold approval of any such requests made by the applicable Institutional Lender. On the Closing Date for each Ground Lease Parcel, and subject to the applicable terms and conditions of this Agreement, the parties to the Ground Lease applicable to such Ground Lease Parcel shall execute and deliver such Ground Lease and a memorandum of such Ground Lease substantially in the form attached hereto as **Exhibit C-2** (each, a “Memorandum of Ground Lease”), which Memorandum of Ground Lease shall be duly recorded by the applicable Developer Party at the Davidson County Register of Deeds (the “Register”). The Premises will comprise multiple parcels that will be demised pursuant to separate Ground Leases (each such parcel, a “Ground Lease Parcel”).

2.4 Cooperation. During the period from the Effective Date until the Closing Date for each Ground Lease Parcel, Owner and Developer will reasonably cooperate and perform their respective obligations pursuant to the terms of this Agreement to complete the design and permitting of the Project and the Developer Infrastructure Work for such Ground Lease Parcel, and to prepare various exhibits to the Ground Lease as contemplated herein, which (together with any applicable provisions of this Agreement) will govern the construction, development, and operation of the Improvements for such Ground Lease Parcel during the term of the applicable Ground Lease.

2.4.1 Owner and Developer each acknowledge and agree that each is a party to certain Site Coordination Documents governing site coordination by and among

Owner, Developer and StadCo. Owner further acknowledges that Owner has certain rights pursuant to the Site Coordination Documents and Stadium Development Agreement to enforce StadCo's obligations to construct the Second Street Plaza Improvements and the Stadium Infrastructure. Owner hereby agrees to exercise all of its rights under the Site Coordination Documents and Stadium Development Agreement to enforce StadCo's obligations to construct the Second Street Plaza Improvements and the Stadium Infrastructure and to cause StadCo to construct the Second Street Plaza Improvements and Stadium Infrastructure. Without the prior written consent of Developer, which consent shall not be unreasonably withheld, conditioned or delayed, Owner will not amend or agree to any amendments or modifications to, waive any rights or obligations, or grant any additional rights under the Site Coordination Documents to which it is a party or to the Stadium Development Agreement that would adversely affect Developer's ability to develop the Project or any portion thereof in accordance with the Development Master Plan. The Parties agree to include a corresponding provision, consistent with the terms of this Section 2.4.1, in the Ground Lease.

2.4.2 Each Party acknowledges that the other Party owns or leases, and may hereafter acquire or lease, other properties in the vicinity of the Premises. Subject to the applicable terms of the Site Coordination Documents and to such Party's express obligations under this Agreement and the applicable Ground Lease(s), nothing in this Agreement or the Ground Leases shall restrict either Party's right to own, operate, lease and otherwise engage in real estate activities with respect to such other properties, whether or not any such projects compete with the Project or the Stadium Project.

2.4.3 Subject to applicable Laws, Owner shall cooperate reasonably (and shall use good faith efforts to cause its Affiliates to cooperate) with Developer by supporting applications for governmental permits and approvals relating to the Project.

## 2.5 Representations of Developer.

2.5.1 Developer represents and warrants that Developer is a limited liability company duly organized, validly existing and in good standing under the laws of the State of Delaware; that Developer is qualified to do business in the State of Tennessee; that Developer has the legal right, power and authority to enter into and perform all of its obligations under this Agreement; that the individuals executing this Agreement have been duly authorized after all requisite action of Developer, to execute the same on behalf of, and to bind, Developer; and that all of the obligations of Developer set forth herein are enforceable against Developer in accordance with their respective terms.

2.5.2 Developer represents and warrants that it is Controlled by Fallon. Developer represents and warrants that the financial statements delivered by Developer and Fallon to Owner are true and correct in all material respects, each as of the respective dates of such financial statements, and as of the Effective Date no

change in the financial condition reflected in such financial statements that could have a material adverse effect on the ability of Developer or Fallon to perform their obligations under this Agreement has occurred since the respective dates thereof.

2.5.3 Developer represents and warrants that its execution of this Agreement and compliance with its terms will not conflict with or result in a breach of any Law, judgment, order, writ, injunction, decree, rule or regulation of any court, administrative agency or other governmental authority to which Developer is subject, or any other agreement, document or instrument by which Developer is bound. Developer further represents and warrants that there are no claims, lawsuits or proceedings to which Developer or any other Developer Party is a party pending in any court or government agency, the outcome of which could materially and adversely affect Developer's ability to perform its obligations under this Agreement.

2.5.4 Developer represents and warrants that Developer has not filed any petition, nor been the party against whom a petition has been filed in relation to any bankruptcy, insolvency, request for reorganization, the appointment of a receiver or trustee, or the arrangement of debt, nor, to the best of Developer's knowledge, is any such action contemplated or threatened.

2.5.5 Developer acknowledges and agrees that Developer has not been influenced to enter into this transaction nor has it relied upon any representations or warranties of Owner whatsoever, except for the representations and warranties of Owner set forth herein.

2.5.6 Developer represents and warrants that Developer has not engaged or worked with any broker or finder in connection with this Agreement or the ground lease transaction contemplated by this Agreement. Developer agrees to indemnify and hold Owner harmless from and against any claims, actions, liabilities, costs and expenses with respect to any brokerage commission, finder's fee or advisory fees asserted by a person, firm or corporation claiming to have been engaged by, through or under Developer.

2.5.7 Developer represents and warrants that neither Developer nor any other Developer Party is a Prohibited Person.

2.5.8 Developer or the applicable Developer Party shall deliver a certificate on the Closing Date for each Ground Lease Parcel certifying that the representations and warranties of Developer set forth in this Section 2.5 are, to the extent applicable to such Ground Lease Parcel, true and complete on such Closing Date (the "Developer Closing Certificate").

2.5.9 Developer shall promptly deliver notice to Owner if Developer obtains actual knowledge that any representation of Developer has become untrue in any material respect during the term of this Agreement. If any representation of Developer shall become untrue, and such breach of representation was not caused

by the Owner's action or failure to act in accordance with the terms of this Agreement or any Ground Lease, in any material way that would materially and adversely affect Developer's ability to comply with its obligations under this Agreement, and Developer shall have thirty (30) days to cure such breach, failing which, Owner shall be entitled, on written notice, given within fifteen (15) Business Days of the expiration of such thirty (30) day period, to terminate this Agreement and, if the breach of the representation constitutes an Developer Event of Default under Section 11.1.1, seek damages from Owner in accordance and subject to Section 11.3(a) and (b). For purposes of this Section 2.5.9, a representation regarding Developer will be deemed untrue in a material respect only if the breach of the representation would reasonably be expected to prevent Developer or Fallon from performing their obligations under this Agreement or prevent Developer from being able to Close on any one or more Ground Leases and perform its obligations thereunder; provided, however, that a breach of the representations and warranties set forth in Section 2.5.2 shall be deemed material in all cases.

## 2.6 Representations and Covenants of Owner.

2.6.1 Owner represents and warrants that Owner has the legal right, power and authority to enter into and perform all of its obligations under this Agreement; that the individual executing this Agreement has been duly authorized, after all requisite action of Owner, to execute the same on behalf of, and to bind, Owner; and that all of the obligations of Owner set forth in this Agreement are enforceable against Owner in accordance with their respective terms.

2.6.2 Owner represents and warrants that the execution of this Agreement and compliance with its terms will not conflict with or result in a breach of any Law, judgment, order, writ, injunction, decree, rule or regulation of any court, administrative agency or other governmental authority to which Owner is subject or any other agreement, document or instrument by which Owner is bound. Owner further represents and warrants that there are no claims, lawsuits or proceedings to which Owner is a party pending in any court or government agency, the outcome of which could materially and adversely affect Owner's ability to perform its obligations under this Agreement.

2.6.3 Owner acknowledges and agrees that Owner has not been influenced to enter into this transaction nor has it relied upon any representations or warranties of Developer whatsoever, except for the representations and warranties of Developer set forth herein.

2.6.4 Owner represents and warrants that Owner has not engaged any broker or finder in connection with this Agreement or the ground lease transaction contemplated by this Agreement. Owner shall be responsible for paying, and hereby agrees to pay, any commission or fees due to RCLCO and any other advisors retained by the Owner pursuant to a separate agreement.

2.6.5 Owner represents and warrants that neither Owner nor any of its Affiliates is a Prohibited Person.

2.6.6 Owner represents and warrants that there are no unrecorded leases or other occupancy agreements affecting the Premises arising by, through, or under Owner, and to Owner's knowledge there are no unrecorded leases or other occupancy agreements affecting the Premises, except in each case as otherwise previously disclosed in writing to Developer.

2.6.7 Owner represents and warrants that Owner has not received any written notice from any governmental authority of any actual or alleged violations of applicable Laws affecting the Premises (including any actual or alleged violations of Environmental Laws at the Premises), except as otherwise set forth in the Environmental Report.

2.6.8 Owner represents and warrants that it is not a party to any service agreement or other contract affecting the Premises or any portion thereof that will continue to be in effect (or otherwise binding on any Developer Party) following the Closing of the applicable Ground Lease, and to its knowledge, there are no service agreements or other contracts affecting the Premises or any portion thereof that will continue to be in effect (or otherwise binding on any Developer Party) following the Closing of the applicable Ground Lease (other than Permitted Encumbrances and the Site Coordination Documents).

2.6.9 Owner represents and warrants that Owner is not a "foreign person" or "foreign corporation" as those terms are defined in Section 1445 of the Internal Revenue Code of 1986, as amended (and the regulations promulgated thereunder).

2.6.10 Owner represents and warrants that Owner has not received any written notice from any other governmental authority of a proposed or contemplated Taking, and to Owner's knowledge there is not any proposed or contemplated Taking, of the Premises or any portion thereof.

2.6.11 Owner represents and warrants that Owner has not committed nor obligated itself in any manner whatsoever to sell or lease (other than this Agreement and the Ground Leases) the Premises or any portion thereof to any party.

2.6.12 Owner shall deliver a certificate on the Closing Date for each Ground Lease Parcel certifying that the representations and warranties of Owner set forth in this Section 2.6 are, to the extent applicable to such Ground Lease Parcel, true and complete on such Closing Date (the "Owner Closing Certificate"). Notwithstanding the foregoing, it shall not be a breach of Owner's obligation to deliver an Owner Closing Certificate if the representations set forth in Section 2.6 as set forth in such Owner Closing Certificate (a) discloses any notices of actual or alleged violations which were caused solely by the acts or omissions of Developer, (b) includes an exception for actual or alleged violations that have been corrected or waived (with no actual or contingent liability or obligation for any Developer

Party or the Ground Lease Parcel in question) on or prior to the applicable Closing Date, or (c) was true when made but has become untrue due to events beyond the reasonable control of Owner and for which Owner, despite using commercially reasonable efforts, is unable to cure (each a “Permitted Owner Breach”).

2.6.13 Owner shall promptly deliver notice to Developer if Owner obtains actual knowledge that any representation of Owner has become untrue in any material respect during the term of this Agreement. If any representation of Owner shall become untrue, and such breach of representation was not caused by the Developer’s or any other Developer Party’s action or failure to act in accordance with the terms of this Agreement or any Ground Lease, in any material way that would materially and adversely affect Owner’s ability to comply with its obligations under this Agreement, the value of the Subject Premises, Developer’s use of the Subject Premises in accordance with the Development Master Plan and the Rezoning, or access to the Subject Premises or portion thereof, and Owner shall have until the earlier of thirty (30) days or any pending scheduled Closing with respect to any Ground Lease Parcel hereunder to cure such breach, failing which, Developer shall be entitled, on written notice, given within fifteen (15) Business Days of the expiration of such period, to terminate this Agreement and, if the breach of the representation constitutes an Owner Event of Default under Section 11.1.3, seek damages from Owner in accordance and subject to Section 11.3(c) and (d). For purposes of this Section 2.6.13, a representation regarding the Premises will be deemed untrue in a material respect only if the breach of the representation would reasonably be expected to increase the cost of the Project with respect to any Ground Lease Parcel by \$250,000.00 or otherwise cause Developer to incur costs in excess of \$250,000.00.

2.7 Interim Covenants of Owner. With respect to each portion of the Premises and Parcel B, from the Effective Date until the date on which such portion of the Premises is leased to a Developer Party pursuant to a Ground Lease or such earlier date on which this Agreement has terminated in whole or with respect to such portion of the Premises, Owner shall:

2.7.1 Not take any action with respect to the Premises that violates the terms of this Agreement or the Site Coordination Documents in any material respect;

2.7.2 not enter into any lease or occupancy agreements with respect to such portion of the Premises or any portion thereof that would be binding of the Subject Premises or the Developer Parties after the Closing with respect to the applicable Ground Lease Parcel, other than Ground Leases with the Developer Parties pursuant to the terms hereof;

2.7.3 without Developer’s prior consent, not enter into any service agreements or other contracts with respect to all or any portion of the Subject Premises which would be binding on Developer (or its applicable Affiliate) or such portion of the Subject Premises following the Closing for any Ground Lease Parcel demising the applicable Subject Premises;

2.7.4 use commercially reasonable efforts to maintain in existence and in effect and good standing all material licenses, permits and approvals that are now in existence with respect to such portion of the Premises or any portion thereof to the extent required by applicable Laws or required to enable the parties to meet the obligations set forth hereunder;

2.7.5 not commence or continue any capital improvements at such portion of the Premises or any portion thereof (except as otherwise in connection with Owner's obligations hereunder or under the Site Coordination Documents, including, without limitation, parking improvements);

2.7.6 not grant any easement or any other lien or encumbrance against such portion of the Premises or any portion thereof other than the Permitted Encumbrances;

2.7.7 not enter into (or permit any Owner Party to enter into) any written or oral agreement or other arrangement, including, without limitation, any term sheet, letter of intent, contract or like agreement for the development or sale of such portion of the Premises or any portion thereof from any Person other than to Developer Parties pursuant to this Agreement and any Ground Leases entered into in accordance with the terms hereof; and

2.7.8 not (and will not permit any Owner Party to): (x) accept or solicit offers or enter into any agreement or understanding with respect to the sale, ground lease, development or similar transaction, or with respect to a joint venture transaction, involving such portion of the Premises or any portion thereof, or (y) otherwise negotiate or enter into any potential transaction with any Person with respect to the sale, ground lease, development or similar transaction, or with respect to a joint venture transaction, involving such portion of the Premises or any portion thereof.

### 3. PREMISES

3.1 Description. In connection with Developer's title and survey review of the Premises, Developer shall have the option to cause the surveyor to provide a legal description of the Premises, which will be attached as **Exhibit B-3** hereto. The perimeter boundaries of the Premises are approximately shown on the premises plan attached hereto as **Exhibit B-2** (the "Premises Plan"). The Premises Plan is illustrative of the proposed, general layout of the Premises and adjacent portions of the Campus but shall not be deemed to be a warranty, representation, or agreement on the part of Owner or the Developer that the Premises, Campus, or any other area or information shown on the Premises Plan (including, without limitation, any depiction of, or reference to, any improvements, infrastructure, use/purpose, tenants/occupants, and/or any other information) is or will be as depicted. Prior to any Ground Lease Parcel Closing, Developer shall prepare or cause its surveyor to prepare legal descriptions for such Ground Lease Parcel, and shall deliver such legal description to Owner, for Owner's review and reasonable approval. Developer shall also be entitled, at any time, to legally subdivide any portion of the Premises in accordance with applicable Laws, at Developer's cost, based on such legal descriptions and



to cause each Ground Lease Parcel to constitute a separate tax lot, and Owner shall reasonably cooperate and execute any applications or other documents that are needed in order to effectuate the foregoing. If, as of the Closing for any Ground Lease Parcel, such Ground Lease Parcel shares a tax lot with any other Ground Lease Parcel or any other property owned by Owner or any of its Affiliates, then the Parties shall cause the relevant owners of such parcels to enter into a customary tax allocation agreement (a “Tax Allocation Agreement”) with respect to such parcels whereby the owners of such parcels agree to be responsible for the taxes equitably allocable to their respective parcels for the period in which such parcels share a tax lot, unless provision for the same is made in the relevant Ground Leases.

3.2 Infrastructure. The Scope of Work Document (**Exhibit D** annexed hereto and discussed in Section 5.2.3 hereof) sets forth certain provisions regarding control of the roadways (whether currently existing or to be constructed in the future) throughout the Campus, inclusive of the Premises, and allocation of the Developer and Owner’s obligations with respect to costs related to the excavation, management, regulatory compliance and offsite disposal of certain soils and groundwater and other matters pertaining to Premises-related infrastructure, parking and certain other common areas of the Project and other portions of the Campus. The Ground Leases shall provide Owner and the applicable Ground Tenant with such rights as may be specified in the Scope of Work Document or otherwise set forth in this Agreement for the purpose of enabling Owner and Developer to construct, maintain and/or own certain public realm improvements, structures, utilities, roadways, and other work on or about the Premises which are required to accommodate substantial future development within the IDA Land and the surrounding areas.

3.2.1 Developer Infrastructure Work. Developer will cause certain of the following Premises-related infrastructure work as shown in the Scope of Work Document to be the obligation of Developer (collectively, “Developer Infrastructure Work”) to be completed in accordance with the applicable provisions of the Scope of Work Document (and Developer shall have such responsibilities with respect to the connection and/or tie-ins to existing public infrastructure as shall be necessary to construct the Project in accordance with the Final Plans subject to and in accordance with the Scope of Work Document):

3.2.1.1 Sanitary sewer infrastructure serving the Project and connecting to the existing sanitary sewer main in accordance with all applicable Metro and State of Tennessee requirements for sewer infrastructure.

3.2.1.2 Storm water drain infrastructure serving the Project stubbed to a connection point as described in the Scope of Work Document.

3.2.1.3 Potable water infrastructure with appropriate connection stubs or connection points as described in the Scope of Work Document.

3.2.1.4 Electrical utilities and appurtenant infrastructure serving the Project with appropriate connection stubs or connection points as described in the Scope of Work Document.

3.2.1.5 Telecommunications utilities and appurtenant infrastructure serving the Project with appropriate connection stubs or connection points as described in the Scope of Work Document.

3.2.1.6 Any infrastructure obligations of TPAC that are assumed by Developer pursuant to Section 3.4.1 of this Agreement.

3.2.1.7 Any other Premises-related infrastructure or remediation work identified in Scope of Work Document or this Agreement, including the environmental obligations and allocation of costs more particularly described herein.

### 3.3 Condition.

3.3.1 Except as expressly provided otherwise in this Agreement or in any applicable Ground Lease, including without limitation Owner's representations and warranties, each Ground Lease Parcel shall be delivered to, and accepted by, the applicable Ground Tenant on the Closing Date for such Ground Lease Parcel in its then condition, "AS IS", "WHERE IS", and "WITH ALL FAULTS", including without limitation, legal title, subsurface conditions, existing structures (if any), the presence of Hazardous Materials, subject to the terms and conditions set forth in this Agreement.

3.3.2 Except for Owner's representations set forth in Section 2.6, Owner has made, and makes, no representations or warranties of any kind, express or implied, in fact or by law, and hereby expressly disclaims any representation or warranty, with respect to such condition or the suitability of the Premises or any Ground Lease Parcel for the uses contemplated in the Ground Leases, and except as otherwise indicated in the Scope of Work Document (including without limitation the payment of money for certain infrastructure obligations), Owner shall have no additional obligation to do any work on or with respect to the Premises or any Ground Lease Parcel.

3.3.3 Developer acknowledges and agrees that, except as otherwise expressly provided in the Scope of Work Document or any applicable Ground Lease, it shall be solely responsible at its sole cost and expense for the installation of (a) all utilities servicing the Project and (b) all utilities tie-ins with respect to utilities from the point of connection to existing public infrastructure (collectively, the "Tenant Utilities Improvements"). Notwithstanding the foregoing, the Parties agree that Owner and not Developer shall be responsible for the incremental costs of increasing the size and/or capacity of any Tenant Utilities Improvements to the extent such increased size and/or capacity is requested by Owner or an instrumentality of Owner.

### 3.4 TPAC Project Improvements; Parcels A and B.

3.4.1 TPAC Project Improvements. The Parties acknowledge that Owner is working with TPAC to develop Parcel E-2 into a performing arts center. In connection therewith, Owner intends to enter into each a development agreement and ground lease with TPAC substantially consistent with the Memorandum of Understanding approved by Metropolitan Council Resolution No. RS2024-\_\_\_\_\_, adopted February \_\_, 2024, and subject to the review and approval by Developer (which approval shall not be unreasonably withheld, conditioned or delayed) to the extent that such Agreements affect the Premises or Developer's Project thereon (collectively, the "TPAC Agreements"). Once Owner and TPAC have executed and delivered the TPAC Agreements, Owner shall enforce its rights and TPAC's obligations to cause TPAC to construct the TPAC Project Improvements (including without limitation the TPAC Pedestrian Bridge Extension Component, TPAC Street Improvements and other TPAC Infrastructure) in accordance with the TPAC Agreements.

3.4.2 If (a) by January 1, 2026, TPAC and Owner have not executed and delivered the TPAC Agreements or (b) Owner or TPAC terminates the TPAC Agreements for any reasons, then in each case, (x) Parcel E-2 shall be deemed to be a part of the Premises, (y) TPAC's construction and funding responsibility, as applicable, in connection with the construction of the roads immediately adjacent to Parcel E as set forth in the Scope of Work Document shall thereafter be the construction and funding responsibility of Developer (or the applicable Developer Party), (z) any and all requirements and obligations of the Parties with respect to the Pedestrian Bridge Extension, including without limitation any obligations to construct the TPAC Pedestrian Bridge Extension and the Developer Pedestrian Bridge Extension, and Development Milestones related thereto, and/or the Pedestrian Bridge Declaration shall cease.

#### 3.4.3 Parcel B Option

3.4.3.1 If Developer satisfies the Parcel B Option Condition Precedent prior to the Outside Parcel B Option Outside Vesting Date, Developer shall have the option, but not the obligation, to develop Parcel B (the "Parcel B Option") subject to and in accordance with the terms and conditions of this Section 3.4.3. If Developer fails to satisfy the Parcel B Option Condition Precedent prior to the Outside Parcel B Option Vesting Date, Developer shall have no further rights with respect to the development of Parcel B. If Developer shall satisfy the Parcel B Option Condition Precedent prior to the Parcel B Option Outside Vesting Date, Developer may deliver written notice (the "Parcel B Option Notice") to Owner of Developer's election to exercise the Parcel B Option in accordance with the terms hereof.

3.4.3.2 Upon Developer's delivery of the Parcel B Option Notice, Owner shall be obligated to work with StadCo and any other applicable third party to deliver Parcel B to Developer free and clear of any leases, licenses, or other

agreements (other than any Permitted Exceptions and the Parking Agreement to the extent applicable to Parcel B) and of any occupants, other than StadCo pursuant to the exercise of its rights under the Parking Agreement (the “Parcel B Delivery Condition”). Owner shall deliver notice (“Parcel B Delivery Condition Notice”) to Developer as soon as practicable, but not later than one (1) year from Owner’s receipt of the Parcel B Option Notice that Parcel B is in Parcel B Delivery Condition or that Parcel B will be in Parcel B Delivery Condition in accordance with the terms of the Parking Agreement. For avoidance of doubt, Owner shall be entitled to send a Parcel B Delivery Condition Notice to Developer prior to Owner’s receipt of the Parcel B Option Notice. Upon Developer’s exercise of the Parcel B Option, (a) Parcel B shall be deemed a part of the Premises for all purposes hereunder, (b) Developer shall be entitled to develop Parcel B for any use permitted by the Rezoning, (c) any hotel developed on Parcel B shall not be subject to the Hotel Maximum, and (d) the Parties shall work together in good faith to determine whether and how to allocate responsibilities related to parking facilities on Parcel B pursuant to the Parking Agreement (which determination the Parties expect will conclude within six (6) months). Developer shall commence construction on Parcel B on or before the Parcel B Commencement Outside Date. For avoidance of doubt, if Developer shall fail to commence construction on Parcel B prior to the Parcel B Commencement Outside Date, Developer shall lose the right to develop Parcel B and Parcel B shall no longer be deemed to be part of the Premises hereunder, however such failure shall in no event be a failure Developer to achieve a Development Milestone hereunder.

#### 3.4.4 Additional Provisions Relating to Parcel A.

3.4.4.1 Notwithstanding anything in this Agreement to the contrary, if Developer fails to commence construction on Parcel A by the Parcel A Commencement Outside Date, Developer shall lose its right to develop on Parcel A and after such time the term “Premises” shall be read and interpreted to exclude Parcel A for all purposes under this Agreement. For avoidance of doubt, Developer’s failure to commence construction on Parcel A by the Parcel A Commencement Outside Date shall in no event be a default hereunder or failure to satisfy a Development Milestone.

#### 3.5 Title/Survey.

3.5.1 Developer Title Objections. Within three (3) Business Days from the Effective Date, (a) Owner shall provide Developer with a copy of any title insurance policies issued in connection with the Premises, legible copies of all documents listed as exceptions to title in such insurance policies, and all existing surveys of the Premises, to the extent that the same are in Owner’s possession or control, (b) promptly upon Owner’s receipt of the same, a survey of the Campus (“Campus Survey”), and (c) upon receipt of any such title documentation described in clause (a) above and the Campus Survey, Developer shall order a commitment for a leasehold title insurance policy from the Title Company (the “Title Commitment”) and shall provide a copy of the Title Commitment to Owner.

Developer may also obtain a current survey of the Premises (the “Survey”) at its sole cost and expense. Developer shall have until the date that is sixty (60) days after the later of Developer’s receipt of the Title Commitment and the Effective Date to give Owner a written notice that sets forth any objections that Developer has to title or survey matters affecting the Premises and disclosed on the Title Commitment or the Survey (the “Developer Title Objections”). Owner shall notify Developer in writing (“Owner’s Title Notice”) of Owner’s election not to cure any Developer Title Objections within fifteen (15) Business Days after receipt of the Developer Title Objection notice. In the event that Owner does not deliver Owner’s Title Notice to Developer within such (15) Business Day-period, Owner shall be deemed to have elected not to cure or satisfy any Developer Title Objections. If Owner shall elect in Owner’s Title Notice, or shall be deemed to have elected, not to cure any one or more Developer Title Objections, Owner shall have no obligation to effectuate the cure of any such Developer Title Objections other than Owner Mandatory Cure Encumbrances; provided, however, that Owner shall cooperate with Developer, at no out-of-pocket expense to Owner, in effecting the cure of any Developer Title Objection, but Owner shall in no event, other than Owner Mandatory Cure Objections and those Developer Title Objections which Owner has elected to cure, be required to bring suit to clear any claimed title or survey defects. If Owner elects not to cure any Developer Title Objections in Owner’s Title Notice, or if Owner does not timely deliver Owner’s Title Notice, then Developer shall have the option (in its sole discretion) of either (y) accepting the title as it then is or (z) terminating this Agreement as to the Affected Ground Lease Parcel, in which case this Agreement shall immediately terminate insofar as it relates to such Ground Lease Parcel(s), and this Agreement shall be void and without further recourse to the Parties insofar as it relates to such Ground Lease Parcel(s), except for those provisions hereof that expressly survive termination hereof. If Developer does not so terminate this Agreement, then all Developer Title Objections other than those that Owner elects, in its sole discretion, to cure in Owner’s Title Notice will constitute Permitted Encumbrances. If Owner elects in Owner’s Title Notice to cure any Developer Title Objections, and Owner is unable or unwilling to cure the applicable Developer Title Objections by the applicable Closing Date, such failure shall be an Owner Event of Default hereunder, and Developer shall have available to it all remedies as set forth in Section 11.3. If Developer does not so terminate this Agreement, then all Developer Title Objections other than those that Owner elects, in its sole discretion, to cure will constitute Permitted Encumbrances. Notwithstanding anything in this Agreement to the contrary, all Mandatory Cure Encumbrances applicable to the subject Ground Lease Parcel will be satisfied by Owner on or prior to the Closing Date for such Ground Lease Parcel and Developer shall have no obligation to give Owner any notice of objection with respect to any Mandatory Cure Encumbrance.

### 3.5.2 Additional Title Matters.

3.5.2.1 If any update to the Title Commitment or the Survey which is dated after the date of the Title Commitment first discloses any title exceptions, defects, encumbrances, or other title or survey matters that could have an adverse

effect on Developer's ability to develop, own, finance, transfer or use the Project or any applicable portion thereof that do not constitute Permitted Encumbrances (each, a "New Title Exception" and collectively, the "New Title Exceptions"), then Developer shall have the right to object to such New Title Exceptions by providing notice of its objection to Owner before the sooner to occur of the Closing for such Ground Lease Parcel or five (5) Business Days after Developer's receipt of the update to the Title Commitment or the Survey, as applicable, and if Developer fails to timely provide such notice of objection, then Developer shall be conclusively deemed to have approved such New Title Exceptions and the same shall constitute Permitted Encumbrances. If Developer timely delivers any such notice with respect to a New Title Exception affecting any Ground Lease Parcel later than five (5) Business Days prior to the Closing for such Ground Lease Parcel, then, at either Party's election, such Closing may be extended for up to five (5) Business Days.

3.5.2.2 If Developer timely provides written notice of its objection to a New Title Exception with respect to any Ground Lease Parcel as to which the Closing has not yet occurred (the "Affected Ground Lease Parcel"), then Owner shall have five (5) Business Days in which to notify Developer whether Owner undertakes to cure such disapproved New Title Exception. If Owner does not provide such written notice within such five (5) Business Day period or does not timely provide such written notice, but then subsequently determines that it is unable to cure the disapproved New Title Exception prior to the Closing with respect to the Affected Ground Lease Parcel and notifies Developer in writing of such determination, then, in either case, Developer shall be entitled, at its option, to exercise the following rights, as applicable:

(a) Developer shall be entitled to terminate this Agreement with respect to the Affected Ground Lease Parcel, upon written notice to Owner within five (5) Business Days of the expiration of such aforementioned five (5) Business Day period if Owner does not deliver a response notice (or within five (5) Business Days of receipt by Developer of the written response notice from Owner indicating that Owner will not or is not able to cure the objected to New Title Exception), in which case this Agreement shall immediately terminate insofar as it relates to such Ground Lease Parcel(s), and this Agreement shall be void and without further recourse to the Parties insofar as it relates to such Ground Lease Parcel(s), except for those provisions hereof that expressly survive termination hereof; or

(b) In the case of a disapproved New Title Exception that is not an Owner Mandatory Cure Encumbrance, Developer shall be entitled to waive such New Title Exception and proceed with the applicable Closing pursuant to the terms and conditions of this Agreement, without offset or other credit or adjustment to the Ground Rent for the applicable Ground Lease Parcel, in which event such New Title Exception shall constitute a Permitted Encumbrance, and Developer shall be conclusively deemed to have waived any claim against Owner with respect to such New Title Exception; or

(c) In the event Developer fails to make a timely affirmative election pursuant to any of clauses (a) or (b), as applicable, Developer shall be deemed to have elected to waive such New Title Exception and proceed with the applicable Closing pursuant to the terms and conditions of this Agreement, without offset or other credit or adjustment to the Ground Rent for the applicable Ground Lease Parcel, in which event such New Title Exception shall constitute a Permitted Encumbrance, and Developer shall be conclusively deemed to have waived any claim against Owner with respect to such New Title Exception.

(d) Notwithstanding the foregoing, in the case of an Owner Mandatory Cure Encumbrance that Owner has failed to cure, Developer shall be entitled to proceed with the applicable Closing, in which case Owner shall promptly reimburse Developer for the actual, documented out-of-pocket costs incurred by Developer to cure any such Mandatory Cure Encumbrance. Owner may elect to reimburse Developer for such costs in the form of a credit against Ground Rent due under one or more Ground Leases; provided, however, beginning on the date that is one hundred twenty (120) days after Developer's demand for reimbursement pursuant to this Section 3.5.2.2, any such costs of Developer that have not yet been reimbursed will bear interest at the Prime Rate until paid, and future credits against Ground Rent under this Section 3.5.2.2 will be increased to include such interest. Nothing in this Section 3.5.2.2 constitutes a waiver by Developer of Owner's obligation to cure all Owner Mandatory Cure Encumbrances affecting a Ground Lease Parcel at or prior to the Closing for such Ground Lease Parcel.

3.5.3 Owner Mandatory Cure Encumbrances. Notwithstanding any other provisions hereof, Owner shall be obligated to cure all of the following: ("Owner Mandatory Cure Encumbrances"), none of which shall constitute Permitted Encumbrances: (i) all delinquent real estate taxes and assessments, (ii) any lien or encumbrance of an ascertainable amount affecting the Subject Premises voluntarily created or assumed by any Owner Party after the date hereof and not created by or resulting from the acts of any Developer Party, (iii) any attachment, lien, or encumbrance on the Subject Premises or any portion thereof that secures the payment of money (including any mortgage and/or deed of trust encumbering the Subject Premises or any portion thereof, and any judgment lien, delinquent tax obligation, mechanics or materialmen's liens) arising by, through, or under Owner, excluding any such attachment, lien or encumbrances caused or created by any Developer Party. For purposes of this Agreement, Owner may "cure" an Owner Mandatory Cure Encumbrance by either discharging such Owner Mandatory Cure Encumbrance by payment (where such payment will cause the matter to be completely satisfied and discharged of record), by posting a bond for payment in full or by causing the Title Company affirmatively to insure over the matter, provided that, in the case of a bond for payment or affirmative insurance, the same is accomplished in a manner and on terms reasonably acceptable to Developer. In addition to the Mandatory Cure Encumbrances, Owner shall be obligated use good

faith efforts to obtain any rights over any CSX property (including without limitation, any easement area) located within or adjacent to the IDA Land necessary to permit TPAC and Developer, as applicable, to complete Waterside Drive adjacent to Parcel E-2 and Parcel F as a sixty three foot (63') right of way (without affecting the size of Parcel F or E-2 as shown on the Development Master Plan), the Parties acknowledging that Parcel E-2 and Parcel F can be developed with a temporary Waterside Drive adjacent to Parcel E-2 and Parcel F as a forty three foot (43') right of way (as shown on the Development Master Plan).

3.5.4 Permitted Encumbrances. The “Permitted Encumbrances” shall mean and include any and all of the following: (i) the Developer Title Objections or New Title Exceptions, if any, that are deemed satisfied or waived under Sections 3.5.1 or 3.5.2; (ii) the printed exceptions, if any, which appear in a standard form leasehold title insurance policy issued by the Title Company in the State of Tennessee; (iii) real estate taxes and assessments not yet due and payable; (iv) present or future governmental restrictions on use, zoning laws, building codes, and other applicable Laws, ordinances, and regulations; (v) any encumbrance (excluding Owner Mandatory Cure Encumbrances) caused or created by any Developer Party (including, without limitation, any arising out of (a) Developer’s subdivision of the Subject Premises or (b) or agreed to in writing by Developer), (vi) the Plaza/Parcel B and C Declaration, (vii) the Pedestrian Bridge Declaration, (viii) the Campus Operations Agreement, (ix), (ix) all matters shown on the Survey, subject to Developer’s right to object thereto under Sections 3.5.1 and 3.5.2; (x) any subdivision plat affecting the IDA Land which has been reviewed and approved by Developer recorded by Owner with Developer’s approval, not to be unreasonably withheld, conditioned, or delayed; (xi) any easement or right of use created in favor of any governmental agency or quasi-governmental agency or any public utility or private company, with the prior approval of the applicable Developer Party which approval may be given or withheld in accordance with the terms of Section 2.3(c) of the Ground Lease, for drainage, electricity, steam, gas, telephone, water, or other service or utility, and the right to install, use, maintain, repair, and replace wires, cables, terminal boxes, lines, service connections, poles, mains, facilities, and the like, upon, under, and across the Subject Premises or any portion thereof that does not unreasonably interfere with the ability to construct or use the Project, the Improvements, or the Developer Infrastructure Work, in each case, as contemplated in the plans for the Project, including the Development Master Plans and the Approved Development Plans; and (xii) matters approved or deemed approved by Developer in accordance with this Section 3.5.

3.5.5 Endorsements to Leasehold Title Policy. Developer may request endorsements to any Leasehold Title Policy insuring the Subject Premises or any portion thereof, but the issuance of such endorsements shall not be a condition to Closing, except for the endorsements set forth on **Schedule 3.5.5** attached hereto (collectively, “Required Endorsements”).

3.6 Site Investigations. Notwithstanding the foregoing, prior to any Closing, Developer may, on not less than two (2) Business Days’ advance written notice to Owner (which may



be by electronic mail to Thomas Cross, tom.cross@nashville.gov or any subsequent Metro Law Director), enter the Premises for the purposes of conducting site diligence activities, surveys and/or appraisals, subject to the following terms, conditions and limitations:

3.6.1 Developer shall keep Owner reasonably informed of all such activities and provide to Owner at least two (2) days in advance the names, addresses and scope of work for each consultant, contractor or agent who will be conducting activities at the Premises.

3.6.2 Developer shall coordinate with Owner prior to and during each visit to the Premises by any Developer's representatives and representatives of Owner may accompany Developer's representatives during each such visit.

3.6.3 Developer shall have the right to take soil samples for the purposes of evaluating the suitability of the soils on the Property for the Project, subject to the Owner's Reasonable Approval.

3.6.4 Developer shall not conduct any invasive environmental tests or inspections without Owner's prior written consent in its sole but reasonable discretion.

3.6.5 Developer shall procure and maintain, and cause Developer's contractors, consultants, agents, and representatives to procure and maintain, insurance with coverages and limits not less than those set forth in **Exhibit F** attached hereto and otherwise comply and cause each of its Developer's contractors, consultants, agents, and representatives to comply with the requirements of **Exhibit F** attached hereto.

3.6.6 All activities and investigations described in this Section 3.6 shall be at Developer's sole expense and shall be conducted in accordance with all applicable Laws, including without limitation, Laws relating to worker safety and the proper disposal of discarded materials, and at such times and in such manner so as to not unreasonably disturb or interfere with the operation or use of any portion of the Campus.

3.6.7 At Owner's request, copies of all final studies and reports prepared by or on behalf of Developer shall be delivered to Owner. Such studies and reports shall be delivered to Owner without warranty or representation from, or liability to, Developer.

3.6.8 Developer shall repair promptly any physical damage caused in connection with its due diligence and shall promptly return the Premises to a same or better condition as existing immediately prior to Developer's due diligence.

3.6.9 The provisions of Section 8.1.1 shall apply with respect Developer's activities under this Section 3.6.

3.7 Stadium Parking Spaces. Developer acknowledges that Owner has certain obligations under the Parking Agreement to provide parking facilities for use by StadCo

during Stadium Event Parking Periods (as defined in the Parking Agreement), including the obligation to maintain at all times not less than 2,000 available spaces within the Campus for such use by StadCo (“Stadium Parking Spaces”). Owner’s intention is that approximately 50% of those parking spaces will be located on the IDA Land. To that end, Owner and Developer shall cooperate in good faith to identify potential options to construct and incorporate Stadium Parking Spaces within the building constructed within the Premises, the Parties acknowledging that (i) Owner will be required to provide funding for the construction and maintenance of any Stadium Parking Spaces and (ii) the provisions of this Section 3.7 shall not obligate the Developer or any applicable Ground Tenant to incorporate Stadium Parking Spaces within the buildings constructed within the Premises.

#### 4. DEVELOPER’S PAYMENTS

##### 4.1 Certain Ground Lease Payments.

###### 4.1.1 Ground Rent.

4.1.1.1 As of the date hereof, the parties have determined that the base price per rentable square foot for each Project use is as set forth on Schedule 4.1.1.1.

4.1.1.2 Rent under each Parcel Ground Lease shall be determined pursuant to the methodology described in **Schedule 4.1.1.2** attached hereto.

#### 5. THE PROJECT; PROJECT PLANS; CONSTRUCTION OF IMPROVEMENTS

##### 5.1 The Project.

5.1.1 Construction of the Project. Developer shall develop, construct upon, improve, and operate the Project on the Premises in accordance with **Schedules 5.1.1.1** through **5.1.1.3** below subject to and in accordance with the terms of this Agreement.

5.1.1.1 **Schedule 5.1.1.1** annexed hereto sets forth certain rights, obligations and responsibilities of the Parties with respect to the Residential Project Component.

5.1.1.2 **Schedule 5.1.1.2** annexed hereto sets forth certain rights, obligations and responsibilities of the Parties with respect to the Office Project Component.

5.1.1.3 **Schedule 5.1.1.3** annexed hereto sets forth certain rights, obligations and responsibilities of the Parties with respect to the Hotel Project Component.

##### 5.1.2 Coordination and Cooperation Regarding Neighborhood Initiatives.

5.1.2.1 Owner and Developer understand the importance of the IDA Land being developed in a manner that achieves the neighborhood aspects envisioned by the Imagine East Bank plan approved by the Metropolitan Planning Department. To that end, Developer agrees that it shall diligently investigate and explore opportunities to incorporate the following facilities and uses within the Project: (a) grocery uses; (b) day-care uses; (c) local retail, restaurant and other businesses oriented toward neighborhood appeal; and (d) cultural facilities.

5.1.2.2 In order to keep Owner informed of Developer's efforts pursuant to this Section 5.1.2, Developer shall meet upon the reasonable request of Owner, (which request may be made, at a minimum, semi-annually) with the Mayor (or his/her designee), the Metropolitan Government Planning Director and the Director of the Metropolitan Government's Office of Economic and Community Development (collectively, the "Metro Representatives") to discuss Developer's efforts in accordance with the foregoing provisions of this Section 5.1.2.

5.1.2.3 The Developer shall reserve the space constructed for the Qualifying Day Care Facility in satisfaction of the First Residential Milestone exclusively for use as a Qualifying Day Care Facility, until such space has been leased to an operator of such facility, or the Developer has engaged an operator to operate such facility.

## 5.2 Project Plans.

5.2.1 Master Plan. The preliminary Development Master Plan is attached as **Exhibit H** (the "Development Master Plan"). The Parties acknowledge that the Development Master Plan may change as Developer further develops the plan and design of the Project, including without limitation on account of input from the Approvals process. Owner shall have the right to review and approve, subject to Owner Reasonable Approval, any material modifications to the Development Master Plan, it being agreed that, among other things, any modification that would materially and adversely affect development on Parcel E-2 by TPAC in accordance with the TPAC Agreements is a material modification and that any rejection of such a proposed modification would not be unreasonable. Owner shall respond to any proposed material modification of the Development Master Plan by written notice to Developer within twenty-five (25) days after receipt of the same and respond in writing to any revision to such modification of a Development Master Plan within ten (10) days after receipt of the same. Owner and Developer shall use good faith efforts to promptly resolve any areas of disagreement with respect to the approval of a modification to the Development Master Plan. If Owner fails to notify Developer of its decision with respect to any submittal of a modification of the Development Master Plan within the time periods required under this Section 5.2.1, Developer shall send to Owner a Second Approval Request in accordance with Section 12.12.2.1. If Owner thereafter fails to notify Developer of its decision with respect to any submittal of a modification of the Development Master Plan within

ten (10) days after Owner's receipt of such Second Approval Request, then such submittal shall be deemed approved by Owner.

5.2.2 Turnover Plan. With respect to each Ground Lease Parcel (or any grouping, as determined by Developer, of Ground Lease Parcels), Developer will deliver to Owner for Owner's Reasonable Approval, a proposed plan (a "Proposed Turnover Plan") that will outline Developer's anticipated construction laydown and staging, access, and construction vehicle parking needs in connection with the development of such Ground Lease Parcel. Owner and Developer will cooperate in good faith to agree upon a mutually agreeable plan to accommodate Developer's reasonable needs as set forth in Developer's Proposed Turnover Plan, which plan will be subject to the Site Coordination Documents (such plan, as approved in writing by Owner and Developer, the "Turnover Plan"). Upon the Parties' mutual agreement with respect to the Turnover Plan, the Parties shall promptly work in good faith to negotiate a temporary construction easement/license agreement to memorialize Owner's agreement to provide for the access, staging, etc. provided for in the Turnover Plan (a "Temporary Construction Easement/License Agreement") on customary terms. Any failure to by the parties to come to agreement on the terms of the Temporary Construction Easement/License Agreement shall be subject to the Expedited Dispute Resolution Procedure.

5.2.3 Scope of Work Document. The Scope of Work Document attached hereto as **Exhibit D** delineates certain obligations of each of Owner and Developer relating to the construction of the Project, inclusive of the construction of the Public Realm Component (other than the TPAC Pedestrian Bridge Component, which will be constructed by TPAC), the performance of the Developer Infrastructure Work and Environmental Obligations of the Parties, including without limitation the allocation of costs therefor and payment mechanisms with respect thereto (such Scope of Work Document, as the same may hereafter be amended with the consent of both Parties is referred to in this Agreement as the "Scope of Work Document").

5.2.4 Final Plans. Developer shall prepare and submit to Owner schematic plans for the Subject Project, for Owner's review and Owner's Reasonable Approval, which review and approval shall be limited to confirming compliance with the Development Master Plan and this Agreement ("Proposed Final Plans"). The Proposed Final Plans for each of the Ground Lease Parcels shall be submitted to Owner not later than the date that is ninety (90) days prior to the date on which Developer proposes to commence construction of Improvements on such Ground Lease Parcel. The Proposed Final Plans for any Ground Lease Parcel, as the same may be approved (or deemed approved) by Owner in accordance with this Agreement, and as the same may be amended by Developer in accordance with the provisions of this Article 5, are referred to in this Agreement as the "Final Plans" for such Ground Lease Parcel, and shall be attached to the applicable Ground Lease as an exhibit thereto. Any request by Developer to modify or amend the Final Plans for any Ground Lease Parcel in any way that would modify the exterior of the applicable Ground Lease Parcel Project or change the primary use of the Ground Lease Parcel such that the exterior or primary use is no longer materially consistent

with the Development Master Plan or this Agreement shall be subject to the Owner Reasonable Approval. Notwithstanding the foregoing, any material proposed modification to the design of the Public Realm Component shall be subject to Owner Reasonable Approval. Developer shall submit final construction drawings for each Subject Project prior to Closing on the Ground Lease for such Subject Project for Owner's review as to consistency with the Final Plans. Owner's approval of any Development Master Plan or Final Plans pursuant to this Section 5.2 will be for purposes of this Agreement only and will not constitute any other Approval required by any Approval Authority under applicable Laws. For avoidance of doubt, Owner shall not be entitled to disapprove any modifications to the Development Master Plan or the Proposed Final Plans on any grounds for which an Approval Authority has authority (i.e., design or zoning) and has previously approved.

### 5.3 The Improvements.

5.3.1 The improvements to be designed, developed, and constructed by Developer as part of the Subject Project shall be as shown and described on the applicable Final Plans for the applicable Ground Lease Parcel (collectively, the "Improvements").

5.3.2 Subject to and in accordance with the terms of the applicable Ground Lease, Developer shall design, develop, and construct the Subject Project, including without limitation all Improvements, in substantial accordance with each of the following: (1) the applicable Development Master Plan, (2) the applicable Final Plans, (3) the Approvals, (4) the applicable Development Budget, (5) the applicable Development Schedule, (6) the applicable Construction Management Plan, (7) all applicable Laws, and (8) this Agreement.

### 5.4 Project Approvals.

5.4.1 Developer agrees that Developer will cooperate with Owner as is reasonably necessary to complete the Rezoning (as defined below), including, without limitation, providing a Public Space Framework Plan that provides details regarding the scale, proportionality, character, and design intent of the public realm aspects of the Project, and such Public Space Framework Plan must be approved by the Metro Nashville Planning Department.

5.4.2 Other than the Rezoning, Developer shall be responsible, at its sole cost and expense, for preparing, filing, pursuing, and obtaining all necessary Approvals for the Project, including, without limitation, subdivision plats, curb cuts and grading, foundation and building permits in accordance with this Section 5.4. Developer shall be the named applicant for all applicable Approvals for the Project, in each case except as otherwise provided in this Section 5.4. Developer shall use diligent and good faith efforts to obtain the Approvals.

5.4.3 Subject to applicable Laws, Owner shall reasonably cooperate with Developer in connection with Developer's efforts to obtain the Approvals (including consideration of changes in the design of the Project or the Developer Infrastructure Work requested by any Approval Authority promptly providing any information reasonably necessary in connection with the Approvals Efforts or requested by any Approval Authority in connection with the Approvals Efforts) and, provided that such requested Approvals applications are not inconsistent with the Development Master Plan, this Agreement, and Site Coordination Documents, shall sign any application for any Approvals for the Project submitted by Developer where the property owner's signature is required.

5.4.4 In connection with applying for and obtaining the Approvals, each Party acknowledges that, except as otherwise expressly provided in this Agreement and the Scope of Work Document, (i) neither Party may rely on any resources owned or controlled by the other Party in connection with the Approvals and (ii) neither Party may enter into any verbal or written agreement with respect to, or consent to the imposition as a condition to the issuance of any Approval of, any obligation, mitigation, or other condition which will be binding upon the other Party, subject to Metro's exercise of governmental powers in the ordinary course.

5.4.5 Developer will keep Owner reasonably apprised of the Developer's Approval Efforts and Approvals Filings.

## 5.5 Project Development Budget.

5.5.1 Developer acknowledges and agrees that each Ground Lease entered into by a Developer Party with respect to a Ground Lease Parcel will require such Developer Party to prepare and deliver to Owner a statement of budgeted total hard costs for the Subject Project for such Ground Lease Parcel (such development budget, as the same may be modified by Developer from time to time in accordance with the terms hereof, being referred to in this Agreement as the "Development Budget" for such Ground Lease Parcel). The Development Budget must be delivered to and approved by Owner Reasonable Approval prior to the Closing for such Ground Lease Parcel provided that Owner's approval shall be limited to verifying that such budget includes the costs necessary to generally meet development costs associated with the development of the Subject Ground Lease Parcel in accordance with the Final Plans for the Subject Project. Notwithstanding the foregoing, in lieu of the foregoing, Developer shall be entitled to deliver to Owner, in lieu of the Development Budget, a report from the third-party construction consultant retained by an Institutional Lender (the "Lender's Project Budget Confirmation") providing financing for the Subject Project stating that the development budget for the Subject Project is adequate to develop the Subject Project substantially in accordance with the Final Plans, so long as either (i) such report is certified to Owner or (ii) the consultant or applicable Institutional Lender acknowledges in writing that Developer is entitled to share such report with Owner. The Development Budget and Lender's Project Budget Confirmation shall be Developer's proprietary information subject to the provisions of Section 12.8.

5.5.2 From time to time with reasonable frequency following or prior to Developer's delivery to Owner of either the Lender's Project Budget Confirmation or a Development Budget for any Ground Lease Parcel in accordance with Section 5.5.1, upon the request of Owner, the applicable Developer Party shall make available to Owner at Developer's Nashville offices on a confidential basis as Developer's proprietary information in accordance with the provisions of Section 12.8 hereof, a then current budget for the Subject Project, including hard costs, soft costs, and contingency and sources and uses of funds (in each case to the extent then available) for review with Developer and provided that Owner take necessary precautions to ensure that the budget and any such information made available to Owner remains confidential.

5.6 Development Schedule; Diligent Efforts.

5.6.1 The anticipated schedule for Developer's design, development, and construction of the initial improvements to be constructed as a part of the Project (the "Preliminary Development Schedule"), is or will be attached hereto as **Exhibit E**.

5.6.2 Developer will be entitled to modify the Preliminary Development Schedule, provided that any modification in the Preliminary Development Schedule (or any future Development Schedule) shall be subject to Owner's approval to the extent that such modification extends the date for performance of any Development Milestone beyond the Outside Date for such Development Milestone. The Preliminary Development Schedule, as the same may be modified in accordance with this Section 5.6.2, is referred to in this Agreement as the "Development Schedule".

5.6.3 Owner acknowledges that the Development Schedule is of critical importance to Developer, and Owner agrees to promptly notify Developer of any modification to the Anticipated Stadium Opening Date.

5.6.4 Excusable Delay:

5.6.4.1 If at any time Developer sends Owner written notice of an alleged Excusable Delay, and Owner in good faith disputes the occurrence of such Excusable Delay, then the Senior Executives shall meet, each acting reasonably and in good faith, to attempt to agree on whether an Excusable Delay has in fact occurred (including the length of such delay). If the Senior Executives are unable to so agree within ten (10) Business Days after Owner's receipt of written notice of an alleged Excusable Delay from Developer, then Developer may submit to Owner an analysis prepared by a reputable third-party appraiser, broker, environmental or geotechnical consultant or other appropriate professional experienced in the commercial real estate market (each, an "Expert") selected by Developer confirming the occurrence of such Excusable Delay. Owner shall promptly respond (but in any event within ten (10) Business Days of Owner's receipt of such analysis) in writing to such analysis by either confirming or continuing, in good faith to

dispute the occurrence of the Excusable Delay. If Owner confirms the occurrence of the Excusable Delay, then the applicable Development Milestone(s) shall be adjusted accordingly.

5.6.4.2 If Owner continues to dispute the occurrence of the Excusable Delay following its review of the third-party Expert's analysis, Owner and Developer shall engage a single additional Expert mutually acceptable to Owner and Developer to determine whether such Excusable Delay has occurred. If the Parties are unable to reasonably agree on such a single additional Expert within ten (10) days after either Party's request, then each Party shall, within ten (10) days after such request, appoint one (1) Expert (each, a "Party Expert"). Developer's Party Expert may, at Developer's option, be the same Expert that prepared the analysis for Developer pursuant to the immediately preceding paragraph. Each Party Expert shall make his or her own independent determination as to whether or not the Excusable Delay has occurred and deliver such determination to both Owner and Developer within fourteen (14) days after the date of the appointment of the last Party Expert. If the Party Experts' determinations with respect to the occurrence of the Excusable Delay are the same, such determinations shall be binding on the Parties. If the Party Experts disagree in their determinations regarding the occurrence of the Excusable Delay, then, unless the Parties otherwise agree on a resolution within ten (10) days after such determinations have been delivered, the two (2) Party Experts shall then appoint a third Expert (a "Neutral Expert") within such ten (10) day period. If the two (2) Party Experts cannot agree upon the appointment of a Neutral Expert within such ten (10) day period, either Developer or Owner or both shall request that JAMS (or any successor thereto) appoint, within seven (7) days after request, an Expert to serve as the Neutral Expert. The Neutral Expert shall determine whether such Excusable Delay has occurred. The Neutral Expert may elect to meet with Owner's Party Expert and Developer's Party Expert to discuss the analysis and conclusions of the two (2) Party Experts. The Neutral Expert shall render a decision within fourteen (14) days after appointment. If the Neutral Expert confirms the occurrence of the Excusable Delay, then the applicable Development Milestones shall be adjusted to account for such Excusable Delay, as well as any further delay caused by Owner's dispute of the existence of an Excusable Delay. Each Party shall pay the fees and expenses of the Party Expert designated by such Party, and one-half of the fees and expenses of any Neutral Expert.

## 5.7 Construction Management Plan.

5.7.1 On or before the date which is ninety (90) days prior to the first Closing with respect to one or more Ground Lease Parcels, Developer shall, with Owner's input, prepare a construction management plan for such Ground Lease Parcels addressing, without limitation, construction scheduling and phasing, delivery of materials, staging and laydown areas, proposed flow of vehicular traffic to and from the Subject Premises during the construction period, perimeter protection and public safety, demolition and dust-management procedures, soil stockpiling and disposal, lighting and security, construction work parking, construction trailer



locations (such construction management plan, as approved by Owner, being referred to in this Agreement as the “Construction Management Plan” for the applicable Ground Lease Parcels). The Construction Management Plan for any Ground Lease Parcel shall be subject to any relevant provisions of the Site Coordination Documents and to Owner Reasonable Approval. Developer may revise the Construction Management Plan for any Ground Lease Parcel from time to time, provided that any revisions to such Construction Management Plan shall be subject to Owner Reasonable Approval. The Ground Lease for each Ground Lease Parcel shall incorporate by reference the applicable provisions of the Construction Management Plan. The portions of the Construction Management Plan, as approved in accordance with the terms and provisions provided in this Agreement, shall be attached as an Exhibit to each Ground Lease for a Ground Lease Parcel.

5.8 Status of Subject Project. Developer shall, from time to time, at reasonable intervals and as circumstances warrant, keep Owner informed (by meetings, conference calls, emails and/or other methods as agreed upon by the Parties) of the status of all material aspects of Developer’s progress in meeting the terms and provisions of this Agreement and its then current schedule for development of the Project, including, without limiting the generality of the foregoing, the status of obtaining of all required Approvals. Without limiting the foregoing, Owner may request in writing from time to time that Developer confirm in writing whether certain events or circumstances identified by Owner constitute Excusable Delay as of the date of such request. Subject to any limitations set forth in the Ground Leases, Owner shall have the right to review and observe the work being performed in connection with the Project by Developer or its employees, agents and contractors to the extent reasonably required by Owner to ensure that such work is being performed in a manner consistent with this Agreement, Site Coordination Documents, and all applicable Laws, provided that Owner does not in any way materially and adversely interfere with Developer’s performance of such work.

5.9 Construction Coordination Agreement. The parties hereby acknowledge that prior to commencement of construction of any Ground Lease Parcel Project on Parcel C, Developer, StadCo and Developer’s General Contractor with respect to such Ground Lease Parcels intend to enter into a construction coordination agreement (the “Construction Coordination Agreement”).

5.10 Coordination of Improvements with Third Party Construction. Developer acknowledges that concurrently with the construction of all or any part of the Subject Project, Owner, StadCo, and/or other third parties engaged by Owner, may be performing certain work in connection with the Stadium Project (as applicable, the “Section 5.10 Work”). Each Party acknowledges that the construction of the Improvements by Developer will require careful attention to and coordination between the construction of the Improvements, on the one hand, and the construction and operation of the Section 5.10 Work by Owner, the StadCo and/or the third parties engaged by Owner in connection therewith, on the other hand. The plans for such coordination shall be a part of any applicable Construction Management Plan or, with respect to StadCo, in the Construction Coordination Agreement and the applicable Site Coordination Documents. Owner

acknowledges that reasonable access to the Premises is necessary for the construction of the Subject Project by Developer and that a high level of cooperation among Developer, Owner and others constructing and operating the Section 5.10 Work is necessary to ensure Developer's reasonable access to the Premises, and thus the timely completion and occupancy of the Subject Project. Developer and Owner agree to cooperate and use reasonable efforts to seek cooperation from others in connection with the coordination of the Section 5.10 Work, the construction and operation of the Section 5.10 Work, and the construction of the Subject Project, including by complying in all material respects with the applicable portions of any applicable Construction Management Plan.

5.11 Developer's General Contractors and Architects.

5.11.1 Developer shall reasonably consult with Owner on the selection of the Architects involved in the Project, but Owner will only have the right to approve such design professional as set forth below in this Section 5.11.1. The general contractor(s) or construction manager(s) engaged by or on behalf of Developer to construct all or any portion of the Project (each, a "General Contractor") and the architect(s) of record and any landscape architect engaged by or on behalf of Developer for the design and construction of the Project (each, an "Architect" and together with the General Contractor(s), the "Third-Party Development Consultants") shall be subject to Owner Reasonable Approval; *provided, however*, that, other than with respect to the Architect for any portion of the Project to be constructed on Parcel E-1 (for which Owner Reasonable Approval shall always be required unless Parcel E-2 shall have theretofore become part of the Premises), Owner shall not be entitled to withhold its approval with respect to any Third-Party Development Consultant that (i) is properly licensed; (ii) has more than 10 years' experience in the field in which Developer proposes to engage the subject Third Party Development Consultant with respect to the Subject Project; and (iii) with respect to a General Contractor, has adequate financial capacity (which, for avoidance of doubt, can mean the ability to appropriately bond the Subject Project) as reasonably determined by Owner, to complete the Subject Project in accordance with the Final Plans. At any time prior to the commencement of construction on any portion of the Project, Developer may request that Owner approve one or more Third Party Development Consultants for such portion of the Project in accordance with this Section 5.11.1.

5.12 No Obligation of Owner. Except as set forth in the Scope of Work Document, Owner shall in no event be required to complete construction of all or any part of the Project, the Improvements, or the Developer Infrastructure Work.

5.13 Project Implementation.

5.13.1 Operation of Public Realm. At or before the first Closing with respect to any ground lease (including without limitation the ground lease with StadCo and any Ground Leases entered into pursuant to the terms hereof), the Owner shall enter into and record with the Register the Plaza/Parcel B and C Declaration. It shall be a condition precedent to Developer's obligation to close under any ground lease, as

well as a Development Milestone Condition, that Owner enter into and record with the Register the Plaza/Parcel B and C Declaration.

5.13.2 Diversity, Equity and Inclusion. In recognition of each of Owner and Developer's commitments to fostering a diverse and inclusive Project, Developer's commitments with respect to diversity, equity and inclusion are set forth on **Schedule 5.13.2**.

5.14 Failure to Meet Development Milestones. If Developer fails to achieve a Development Milestone by the applicable Outside Date, and such failure is not result of an Excusable Delay (subject to the provisions of Section 5.6.4), Owner shall be entitled as its sole remedy for such delay to either (a) waive any such delay and proceed in accordance with the terms of this Agreement or (b) by written notice delivered on or before the date which is fifteen (15) days after the date on which such determination was made, terminate this Agreement. In no event shall any failure to achieve a Development Milestone be an Event of Default hereunder.

5.15 Termination of Project. If by December 31, 2024, the Rezoning has not occurred in the manner contemplated by Section 6.3.6 due to the inability of Owner and Developer to agree on the Rezoning, either Party shall have a right to terminate this Agreement subject to the right by each Party to extend such date by up to thirty (30) days to continue to work in good faith to resolve any Rezoning dispute. The Applicable Metro Staff and/or the Metropolitan Planning Department and Developer shall each act reasonably and in good faith in an effort to achieve a Rezoning on terms acceptable to both Parties.

## 6. CLOSING OF GROUND LEASE TRANSACTION

6.1 Place and Time of Closing. Subject to the satisfaction and fulfillment of the applicable conditions as set forth in this Agreement, the Closing with respect to each Ground Lease Parcel shall take place through a customary escrow closing not later than 3:00 p.m., local time, on a date to be specified by Developer following the date on which the conditions set forth in Section 6.4 have been or are anticipated by Developer to be satisfied with respect to such Ground Lease Parcel (the "Closing Date" for such Ground Lease Parcel). Developer shall deliver written notice (a "Closing Notice") of any Closing Date to Owner on a date which is not less than sixty (60) days prior to such Closing Date, subject to Developer's right to extend the Closing date as set forth below. Developer may, by written notice delivered to Owner prior to then-scheduled Closing Date, extend the Closing Date from time to time to a date that is not later than the Outside Date for any Development Milestone applicable to such Ground Lease Parcel, as specified in Section 5.6.2; provided, however, that Developer shall have no right to extend the Closing Date if Owner has exercised its right to terminate this Agreement pursuant to Section 5.14.

6.2 Conditions Precedent to Owner's Obligations. Owner's obligation to close with respect to any Ground Lease Parcel shall be subject to satisfaction (or waiver by Owner), on or prior to the applicable Closing Date (as the same may be extended as provided in Section 6.1), of the following contingencies:

6.2.1 No Defaults. There shall be no continuing Event of Default by Developer under this Agreement, nor shall there exist any terminable Event of Default under any Ground Lease to which an Affiliate of Developer is a party beyond any applicable notice and cure periods thereunder.

6.2.2 Approved Final Plans and Construction Management Plan. The Final Plans and Construction Management Plan with respect to the Improvements proposed to be constructed by Developer on such Ground Lease Parcel shall have been approved by Owner in accordance with the applicable provisions of Section 5.2.4 and Section 5.7.

6.2.3 Guarantor Identification. Developer shall have identified the Guarantor(s) with respect to such Ground Lease Parcel, if such Guarantor(s) shall not theretofore have been identified.

6.2.4 Completion Guaranties. At the Closing with respect to such Ground Lease Parcel, Developer shall deliver to Owner a Completion Guaranty in the form attached hereto as **Exhibit G** from a Pre-Approved Guarantor or another Guarantor approved by Owner in accordance with this Agreement.

6.2.5 Approvals and Permits. Developer shall have obtained and submitted to Owner evidence of site plan approval and a copy of the grading permit required in connection the commencement of construction of the Improvements proposed to be constructed by Developer on such Ground Lease Parcel, such site plan approval and grading permit to be valid and in full force and effect.

6.2.6 Insurance. Developer shall have submitted to Owner certificates of insurance evidencing the policies of insurance and insurance coverages required by the terms of the Ground Lease for such Ground Lease Parcel to be in existence at the commencement of the term thereof, such policies to comply with the requirements of such Ground Lease.

6.2.7 Development Budget. Developer shall have delivered to Owner the Development Budget or a Lender's Project Budget Confirmation for such Ground Lease Parcel in accordance with the applicable provisions of Section 5.5.

6.2.8 Financing Assurances. Developer shall have delivered to Owner evidence, reasonably satisfactory to Owner, that the applicable Developer Party will close concurrently with Closing on the Ground Lease Parcel, debt financing, equity financing, or public or private incentives financing (or any combination thereof) that, when combined with the Developer Party's equity, is reasonably anticipated to be sufficient to pay all hard and soft costs set forth in the applicable Development Budget.

6.2.9 Other Documents. All documents required to be executed or delivered by any Developer Party in connection with the applicable Closing shall have been fully executed and delivered by such Developer Party.

6.2.10 Closing Deliverables. Developer shall have delivered or caused to be delivered to Owner or the Title Company, as applicable, at or prior to the Closing for any Ground Lease Parcel, the following items executed and acknowledged by Developer or such other party, as appropriate:

6.2.10.1 two (2) counterpart originals of the Ground Lease for such Ground Lease Parcel (the “Subject Ground Lease”);

6.2.10.2 two (2) counterpart original signatures of any Tax Allocation Agreement required under Section 3.1 to be entered into with respect to such Ground Lease Parcel;

6.2.10.3 the Developer Closing Certificate;

6.2.10.4 such further instruments as may be reasonably required by the Title Company to consummate the transactions under this Agreement in respect of such Ground Lease Parcel;

6.2.10.5 evidence reasonably satisfactory to Owner and the Title Company respecting the due organization of Developer and the due authorization and execution by Developer of this Agreement and the documents required to be delivered under this Agreement in respect of such Ground Lease Parcel; and

6.2.10.6 a joinder of the Ground Tenant to the Campus Operations Agreement in the form and substance required by the Campus Operations Agreement.

6.2.10.7 Parcel-Specific Conditions. If applicable to the Ground Lease Parcel, the conditions and requirements set forth in Sections 3.4.1, 3.4.2 and 3.4.3 must have been satisfied in full.

6.3 Conditions Precedent to Developer’s Obligations. Developer’s obligation to close (or cause one or more other Developer Parties close) with respect to any Ground Lease Parcel shall be subject to the satisfaction (or waiver by Developer), on or prior to the applicable Closing Date (as the same may be extended as provided in Section 3.5.2.1 and/or Section 6.1), of the following contingencies:

6.3.1 Title Insurance Policy. As of the applicable Closing Date, the Title Company shall be irrevocably committed to issue upon the applicable Closing a ALTA leasehold title insurance policy insuring the leasehold title to such Ground Lease Parcel subject only to the Permitted Encumbrances, together with any Required Endorsements (each, a “Leasehold Title Policy”);

6.3.2 Approvals. Developer shall have obtained and submitted to Owner evidence of site plan approval and a copy of the grading permit required in connection the commencement of construction of the Improvements proposed to be constructed by Developer on such Ground Lease Parcel, such site plan approval and grading permit to be valid and in full force and effect.

6.3.3 Owner's Responsibilities. Owner shall not be in default in any material respect of any of its obligations under this Agreement beyond any applicable notice and cure periods.

6.3.4 Existing Property Contracts. All contracts affecting the Subject Premises, other than the Site Coordination Documents, the Plaza/Parcel B and C Declaration, the Pedestrian Bridge Declaration, and other Permitted Encumbrances, shall be terminated or otherwise modified such that they are not binding on Developer or the Subject Premises following Closing.

6.3.5 Environmental. No Hazardous Materials have been released at or otherwise migrated to the Subject Premises in violation of any Environmental Law or that require any remediation or investigation in a manner that increases Subject Project costs by more than a *de minimis* amount, other than as disclosed in the Environmental Report or contemplated in the Environmental MOU.

6.3.6 Rezoning. The IDA Land shall have been rezoned to the Downtown Code (DTC) zoning classification, with a special East Bank district that would permit Developer's development of the Project in accordance with the Development Master Plan and this Agreement, with the reasonable input of and reasonably satisfactory to Developer (the "Rezoning").

6.3.7 Parcel-Specific Conditions. If applicable to the Ground Lease Parcel, the conditions and requirements set forth in Sections 3.4.3 and 3.5.3 must have been satisfied in full.

6.3.8 Parking Agreement. Owner shall over removed the Parking Agreement from title with respect to the applicable Ground Lease Parcel.

6.3.9 Pedestrian Bridge Extension Declaration. The Pedestrian Bridge Extension Declaration shall have been approved by Owner, Developer, and TPAC and shall be fully executed and or recorded with the Register.

6.3.10 Other Documents. All documents required to be executed or delivered by Owner in connection with the applicable Closing shall have been fully executed and delivered by Owner.

6.3.11 Closing Deliverables. Owner shall have delivered or caused to be delivered to Developer or the Title Company, as applicable, at or prior to the Closing for any Ground Lease Parcel, the following items executed and acknowledged by Owner or the applicable ground lessor under the Ground Lease (each, a "Ground Landlord"), as appropriate:

6.3.11.1 two (2) counterpart originals of the Subject Ground Lease;

6.3.11.2 two (2) counterpart original signatures of any Tax Allocation Agreement required under Section 3.1 to be entered into with respect to such Ground Lease Parcel;

6.3.11.3 the Owner Closing Certificate;

6.3.11.4 a customary seller/ground lessor affidavit that contains all statements necessary to enable the Title Company to issue a leasehold owner's policy in favor of the Developer Party executing the subject ground lease without exception for any so-called "standard exceptions" from the Leasehold Title Policy;

6.3.11.5 such further instruments as may be reasonably required by the Title Company to consummate the transactions under this Agreement in respect of such Ground Lease Parcel;

6.3.11.6 for any portion of the Premises that will not be ground leased to Developer pursuant to the Subject Ground Lease on which any Development Milestone improvements are to be constructed or on which construction staging is required, Developer's receipt of Owner's executed counterpart to a mutually acceptable form of access agreement with respect to such portion of the Premises;

6.3.11.7 evidence reasonably satisfactory to each of Developer and the Title Company respecting the due organization of each of Owner and the Ground Landlord, the due authorization and execution by Owner of this Agreement and the documents required to be delivered hereunder and the due authorization and execution by the Ground Landlord of the Subject Ground Lease and the documents required to be delivered under this Agreement in respect of such Ground Lease Parcel; and

6.3.11.8 a certification from the applicable Ground Landlord that such Person is not a "foreign person" as such term is defined in Section 1445 of the Internal Revenue Code, as amended and the regulations thereunder, which certification shall be signed under penalty of perjury.

6.4 Development Milestone Conditions. Developer's obligation to perform any Development Milestone by the applicable Outside Date shall be contingent on the satisfaction of each of the following conditions (each a "Development Milestone Condition" and collectively, the "Development Milestone Conditions"):

6.4.1 The Rezoning shall have occurred, and the Plaza/Parcel B and C Declaration shall have been recorded with the Register.

6.4.2 The Subject Premises on which any Development Milestone improvements are to be constructed is vacant and free and clear of all occupants or Owner has provided Developer with assurances reasonably acceptable to Developer that the Subject Premises will be vacant and free and clear of all occupants within thirty (30) days of Developer sending a Closing Notice for the applicable Subject Premises.

6.4.3 To the extent necessary for Developer to cause the construction of any Improvements on a particular Parcel in order to satisfy a Development Milestone, (i) all of the roads and parcels within such Parcel shall have been delineated and, as

applicable, subdivided, and (ii) any Infrastructure Work to be completed by Owner, TPAC or StadCo (or an Affiliate thereof) as a prerequisite to the development of such Parcel shall have been completed or, if not completed, Developer shall have received adequate assurance reasonably acceptable to Developer that such Infrastructure Work will be completed in sufficient time to enable Developer to cause the construction of any Improvements on a particular Parcel in order to satisfy a Development Milestone, , and (iii) Owner and Developer shall have determined the location of a garage, if any, to be constructed for Owner's benefit on Parcel C, and to the extent that the Parties have agreed that Developer will construct any such garage at Owner's expense, Developer and Owner shall have entered into a mutually agreeable separate agreement with respect to Developer's construction of the garage. **Exhibit D** (Scope of Work Document) identifies the specific items of Infrastructure Work to be completed by Owner, TPAC or StadCo (or an Affiliate thereof) that are prerequisites to the development of individual Parcels. The Parties acknowledge and agree that (x) the First Residential Development Milestone and the Hotel Project Component Milestone are dependent on satisfaction of the requirements set forth in (i), (ii) and (iii) above with respect to Parcels C and G, (y) the Second Residential Development Milestone and the Third Residential Development Milestone are dependent on satisfaction of the requirements set forth in (i) and (ii) above with respect to Parcels C, D, E, F and G, and (z) the Developer Pedestrian Bridge Extension Milestone is dependent on satisfaction of the requirements set forth in (i) and (ii) above with respect to Parcel D and Parcel E-1.

## 6.5 Waiver of Conditions.

6.5.1 In the event that any condition set forth in Section 6.2 has not been fulfilled on or before the Closing Date with respect to any Ground Lease Parcel (as the same may be extended in accordance with the applicable provisions of this Agreement), Owner, in its sole and absolute discretion, may elect to waive such condition and proceed with Closing, it being understood that the preceding sentence is solely for the benefit of Owner and that Owner shall have no obligation to proceed with Closing until such condition has been fulfilled.

6.5.2 In the event that any condition set forth in Section 6.3 has not been fulfilled on or before the Closing Date with respect to any Ground Lease Parcel (as the same may be extended in accordance with the applicable provisions of this Agreement), Developer, in its sole and absolute discretion, may elect (x) to waive such condition and proceed with Closing or may elect, or (y) to terminate this Agreement with respect to the Ground Lease Parcel for which this Section 6.5.2 is invoked. Developer shall have no obligation to waive any such condition, it being understood that the preceding sentence is solely for the benefit of Developer.

6.6 Failure to Close: If Owner has exercised its right to terminate this Agreement in accordance with Section 5.14 after Developer has sent a Closing Notice in accordance with Section 6.1 above and the Closing pursuant to such Closing Notice has not occurred by the Closing Date pursuant to such Closing Notice, as such date may be extended as provided in Section 3.5.2.1 or Section 6.1, then either Party may terminate this Agreement as to the



applicable Ground Lease Parcel by written notice to the other Party delivered within fifteen (15) days after the Closing Date, as extended.

## 7. RESTRICTIONS ON ASSIGNMENT AND SUBLEASE

### 7.1 Assignability.

7.1.1 Except as otherwise expressly permitted under Section 7.1.2 or Section 7.1.3, neither Party shall directly or indirectly transfer (by assignment or otherwise) all or any portion of its interest under this Agreement, the Premises, or any portion the Campus on which any of the Developer Infrastructure Work is to be performed pursuant to this Agreement or the applicable Ground Lease(s) without the prior written consent of the other Party, which consent may be withheld by such Party in its sole and absolute discretion. Without limiting the foregoing, except as otherwise expressly permitted under Section 7.1.2, Developer shall not cause or permit any transfer or assignment of any legal or beneficial interest in Developer without the prior written consent of the Owner, which consent may be withheld by Owner in its sole and absolute discretion.

7.1.2 Notwithstanding any other provision contained in this Agreement to the contrary, Developer may, without Owner's prior consent but upon no less than thirty (30) days' prior written notice to Owner, (i) assign all of its rights and obligations under this Agreement to an Affiliate of Developer or any other Person that is Controlled by one or more Approved Control Persons, subject to customary major decision and removal rights, so long as Developer provides evidence reasonably satisfactory to Owner that the proposed assignee is in fact Controlled by one or more Approved Control Persons; (ii) assign its rights and obligations under this Agreement with respect to any Ground Lease Parcel to an Affiliate of Developer or any other Person that is Controlled by one or more Approved Control Persons, so long as Developer provides evidence reasonably satisfactory to Owner that the proposed assignee is in fact an Affiliate of Developer; (iii) transfer of any direct or indirect beneficial interest in Developer between or among two or more of the individuals or entities (A) that own direct or indirect beneficial interests in Developer as of the Effective Date or (B) that acquire direct or indirect beneficial interests in Developer subsequent to the Effective Date; and (iv) transfer less than all of the outstanding ownership of Developer, so long as, in the case of each of (i), (ii), (iii), and (iv) above, after giving effect to such assignment or transfer, (x) Developer is still Controlled by one or more Approved Control Persons, (y) Fallon remains liable for its obligations under Section 13 of this Agreement, and (z) such proposed assignee or transferee is not subject to any ongoing Event of Default under any Ground Lease beyond any applicable cure or grace periods set forth in such Ground Lease. Notwithstanding the foregoing, Developer shall be entitled, without the consent of Owner but upon no less than thirty (30) days' prior written notice to Owner, to assign this Agreement as to any Income Restricted Residential Building to any Income Restricted Residential Building.

7.1.3 Notwithstanding any other provision contained in this Agreement to the contrary, upon no less than 30 days' written notice to Developer, Owner may, without Developer's prior consent, (i) transfer fee title to the Premises (and any other land in the Campus) to the East Bank Authority, (ii) assign this Agreement or delegate all of its duties under this Agreement to the East Bank Authority, or (iii) lease the Premises to the East Bank Authority; provided, however, that no such assignment of transfer may affect Developer's rights under this Agreement. Upon any assignment of all of Owner's rights and obligations under this Agreement to the East Bank Authority, Owner shall be relieved of all obligations under this Agreement arising after the date of such assignment so long as the East Bank Authority assumes such obligations of Owner. Developer hereby agrees to execute and deliver, or cause to be executed and delivered, such amendments to this Agreement and further instruments as may reasonably be requested by Owner or the East Bank Authority, in form and substance reasonably acceptable to Developer, to reflect any transfers permitted under this Section 7.1.3.

7.2 Prohibited Transfers. Notwithstanding any other provision contained in this Agreement to the contrary, neither this Agreement nor any legal or beneficial interest in Developer may be assigned or otherwise transferred to any of the following:

7.2.1 Any Prohibited Person; or

7.2.2 Any individual or entity that (directly or indirectly) Controls, is Controlled by, or is under common Control with, any Prohibited Person, with the term "Control" meaning the power to direct the management or policies of an entity or conduct the day-to-day business operations of such entity (directly or indirectly), whether through the ownership of voting securities, partnership or other ownership interests, by contract or otherwise (including being the general partner, officer or director of the entity in question); provided, however, that Control shall not be deemed absent solely because a non-managing member, partner or shareholder has the right to approve certain major decisions.

7.2.3 For purposes of this Agreement, the term "Prohibited Person" shall mean:

- i. any Person (or any Person whose operations are directed or controlled by a Person) that Developer has knowledge of (a) having been convicted of a felony in a criminal proceeding; (b) is an organized crime figure, (c) being reputed to have substantial business or other affiliations with an organized crime figure, and (d) being an ongoing target of a grand jury investigation convened pursuant to applicable statutes concerning organized crime;
- ii. any Person listed in the Annex to, or otherwise subject to the provisions of, the Executive Order No. 13224 on Terrorist Financing, effective September 24, 2001, and relating to Blocking Property and Prohibiting Transactions With Persons Who Commit, Threaten to Commit, or Support Terrorism (the "Executive Order");

- iii. any Person that is owned or controlled by, or acting for or on behalf of, any person or entity that is listed to the Annex to, or is otherwise subject to the provisions of, the Executive Order;
- iv. any Person who has been identified by any United States governmental authority having jurisdiction with respect to such matters as a Person who commits, threatens or conspires to commit or supports “terrorism” as defined in the Executive Order;
- v. any Person that is named as a “specially designated national and blocked person” on the most current list published by the U.S. Treasury Department Office of Foreign Assets Control at its official website, [www.treasury.gov/ofac/downloads/sdnlist.pdf](http://www.treasury.gov/ofac/downloads/sdnlist.pdf), or at any replacement website or other replacement official publication of such list; and
- vi. any country, or any Person that, directly or indirectly, is controlled (rather than only regulated) by a government, the effects of the activities of which are regulated or controlled pursuant to regulations of the United States Treasury Department or executive orders of the President of the United States of America issued pursuant to the following: (a) the Trading with the Enemy Act of 1917, as amended, (b) the International Emergency Economic Powers Act of 1976, as amended, and (c) the Anti-Terrorism and Arms Export Amendments Act of 1989, codified at Section 6(j) of the Export Administration Act of 1979, as amended;
- vii. any Person that controls, is controlled by, or is under common control with (including any indirect partners, members, principals or controlling equity investors thereof) any nation, organization or group adjudicated in violation, or under indictment for violation, of or under any applicable anti-money laundering and antiterrorist laws, regulations, rules, executive orders and government guidance (including, without limitation, USA PATRIOT Act, and other authorizing statutes, executive orders and regulations administered by the Office of Foreign Assets Control of the U.S. Department of Treasury), and other agency rules and regulations;
- viii. with respect to any direct transfer of this Agreement, any Person that is in pending litigation with Metro (or litigation threatened in writing against Metro); provided that (A) tax appeals and other disputes regarding administrative governmental functions shall not be considered litigation for the purposes of this provision, and (B)(i) Owner shall deliver written notice of any such pending or threatened litigation within two (2) Business Days of Developer providing Owner with notice of the identity of any such Person and (ii) Developer shall be entitled to rely on such notice or lack thereof for

a period of up to ninety (90) days after Developer's receipt of the same;

- ix. to the extent that this Agreement constitutes a contract to acquire or dispose of services, supplies, information technology, or construction for the purposes of Tennessee Code Annotated Section 12-4-119 (as the same may be amended, supplemented, or replaced from time to time), any Person engaged in a "Boycott of Israel" (as that phrase is defined in such Section); or
- x. any "sanctioned nonresident alien," "sanctioned foreign business," or "sanctioned foreign government" as those phrases are defined in Tennessee Code Annotated Section 66-2-301 (as the same may be amended, supplemented, or replaced from time to time).

## 8. INDEMNIFICATION AND INSURANCE

### 8.1 Indemnification.

8.1.1 Indemnification by Developer. Notwithstanding anything to the contrary herein, Developer, hereby agrees to indemnify and defend each and all of the Owner Parties from and against all claims, reasonable actual documented out-of-pocket costs, fees, reasonable actual documented out-of-pocket expenses, liabilities and damages (including without limitation reasonable outside attorneys' and experts' fees and costs of investigation and litigation) and to hold each and all of the Owner Parties harmless from and against any and all losses, out-of-pocket costs, fees, suits, damages, claims, obligations or liabilities, including, but not limited to, mechanics' liens and reasonable outside attorneys' fees, arising out of or in connection with Developer's activities undertaken by, for or on behalf of Developer in its implementation of this Agreement or its activities with respect to the Project; provided, however, that the foregoing indemnity obligations shall not apply with respect to Excluded Claims. The obligations of Developer under this Section 8.1.1 shall survive any termination of this Agreement.Release by Owner. Owner hereby releases the Developer Parties to the extent of all losses, out-of-pocket costs, fees, suits, damages, claims, obligations or liabilities, including, but not limited to, mechanics' liens and reasonable outside attorneys' fees caused by (i) Owner's activities undertaken by, for or on behalf of Owner in its implementation of this Agreement or (ii) the performance of Owner's other obligations under the Scope of Work Document; provided, however, that the foregoing release shall not apply with respect to (w) any Claims for which Developer is expressly obligated to indemnify the Owner Parties pursuant to Section 8.1.1; and (x) Excluded Claims. The obligations of Owner under this Section 8.1.2 shall survive any termination of this Agreement.

If either (i) Owner assigns it rights and obligations under this Agreement to a Person that is neither an Affiliate of Landlord nor a governmental or quasi-governmental entity or (ii) the Constitution of the State of Tennessee is amended to expressly

permit political subdivisions of the State of Tennessee to provide indemnification, then from and after the closing of such assignment or the date of such amendment (as applicable), this Section 8.1.2 shall automatically be amended and restated to provide as follows:

8.1.2.1 Indemnification by Owner. Notwithstanding anything to the contrary herein, Owner, at its sole cost and expense, hereby agrees to indemnify and defend each and all of the Developer Parties, their officers, directors, members, managers, and owners, from and against all claims, reasonable actual documented out-of-pocket costs, fees, reasonable actual documented out-of-pocket expenses, liabilities and damages (including without limitation reasonable outside attorneys' and experts' fees and costs of investigation and litigation) and to hold each and all of the Developer Parties harmless from and against any and all losses, out-of-pocket costs, fees, suits, damages, claims, obligations or liabilities, including, but not limited to, mechanics' liens and reasonable outside attorneys' fees, to the extent caused by (i) Owner's activities undertaken by, for or on behalf of Owner in its implementation of this Agreement or (ii) the performance of Owner's other obligations under the Scope of Work Document; provided, however, that the foregoing indemnity obligations shall not apply with respect to Excluded Claims. The obligations of Owner under this Section 8.1.2 shall survive any termination of this Agreement.

8.1.3 Additional Indemnification Procedures.

8.1.3.1 If any action or proceeding is brought by a third-party (A) against one or more Owner Parties (each, an "Owner Indemnified Party") in respect of any Claim that is covered by Section 8.1.1, or (B) against one or more Developer Parties (each, a "Developer Indemnified Party"; each Owner Indemnified Party or Developer Indemnified Party, as applicable, being sometimes referred to as an "Indemnified Party") in respect of any Claim that is covered by Section 8.1.2, the Indemnifying Party (as hereinafter defined), upon notice from the Indemnified Party, shall defend such action or proceeding by counsel approved by the Indemnified Party in writing, such approval not to be unreasonably withheld, conditioned or delayed, but no approval of counsel shall be required in any instance where the Claim is defended by counsel of an insurance carrier obligated to defend such Claim. In the event that counsel selected by the Indemnifying Party is reasonably disapproved by the Indemnified Party, and the reasons for such disapproval are provided to the Indemnifying Party in writing, then unless the Indemnifying Party shall propose alternative counsel reasonably acceptable to the Indemnified Party, the Indemnified Party may, at the Indemnifying Party's reasonable expense, retain its own counsel. As used herein, "Indemnifying Party" shall mean (x) Developer, in the context of any Claim against one or more Owner

Indemnified Parties, and (y) Owner, in the context of any Claim against one or more Developer Indemnified Parties.

8.1.3.2 If any third-party Claim shall be made against an Indemnified Party, or if any action or proceeding shall be brought against an Indemnified Party as set forth in Section 8.1, such Indemnified Party shall give written notice thereof to the Indemnifying Party so as to enable such Indemnifying Party to defend such Claim, action or proceeding. Failure to give the notice referred to in the immediately preceding sentence shall not affect or diminish the indemnity set forth herein, except to the extent the Indemnifying Party is prejudiced thereby, and except that the Indemnifying Party shall not be responsible for any defense costs or expenses, including attorneys' fees, incurred by the Indemnified Party prior to delivery of such notice to the Indemnified Party. Provided the Indemnifying Party is defending a third-party action or proceeding in accordance with this Section 8.1.3.2, the Indemnified Party shall not enter into any settlement of such action or proceeding without the approval of the Indemnifying Party, such approval not to be unreasonably withheld, conditioned, or delayed. The Indemnifying Party shall have the right to compromise and settle all such Claims that are susceptible of being settled, provided that the Indemnifying Party shall be required to obtain each applicable Indemnified Party's prior written consent in order to settle, compromise or offer to settle any claims by third parties that would result in a finding or admission of a violation of law or a violation of the rights of any Person by the Indemnified Party or its Affiliates. Each Indemnified Party shall cooperate in all reasonable respects with the Indemnifying Party in defending any third-party Claim covered by Section 8.1.

8.1.3.3 An Indemnifying Party shall have no obligation to indemnify any Indemnified Party from and against any or all amounts in respect of consequential damages, special damages, incidental damages, lost profits, or punitive damages, except, in each case, to the extent such damages are awarded to a third party in connection with a third-party Claim. The amount of any indemnification obligation under Section 8.1 shall be reduced by (i) any amounts realized by the Indemnified Party as a result of any indemnification, contribution or other payment by any party other than the Indemnified Party, (ii) any insurance proceeds or other amounts realized by the applicable Indemnified Party from parties other than the Indemnified Party with respect to such amounts and (iii) any tax savings or benefit actually realized (on a "with and without basis") by the applicable Indemnified Party from the incurrence or payment of amounts as a result of the applicable Claim; provided that any such reduction shall be net of any actual costs, expenses or premiums incurred in connection with securing or obtaining such payments by any party other than the Indemnified Party, such insurance proceeds (including any increased premiums resulting therefrom) or such tax savings or benefits. Each Indemnified Party agrees to timely make and diligently pursue any claims for insurance, tax benefits and/or other payments available from parties other than such Indemnified Party prior to seeking indemnification under Section 8.1.

8.1.3.4 To the extent that an Indemnifying Party makes any indemnification payment to an Indemnified Party pursuant to Section 8.1 that should have been paid by a party other than such Indemnified Party, including to the extent such Indemnified Party is entitled to recover any amount with respect to a Claim under any insurance maintained by any Person on behalf of such Indemnified Party, then (i) the applicable Indemnifying Party shall be fully subrogated to the rights of such Indemnified Party against such third party for such payment, (ii) such Indemnified Party shall assign to the applicable Indemnifying Party all of its rights to such indemnification, advancement or contribution and provide reasonable cooperation, at the expense of the Indemnifying Party, to recover payments through such indemnification, advancement or contribution, (iii) such Indemnified Party shall not waive, release or otherwise compromise the indemnity or contribution from such third party and (iv) to the extent such Indemnified Party receives any proceeds of any indemnification, advancement or contribution from any third party, such Indemnified Party shall promptly reimburse the applicable Indemnifying Party for any indemnification the Indemnifying Party has separately provided to such Indemnified Party up to an amount which is the lesser of (1) the aggregate amount of such proceeds and (2) the indemnification payment such Indemnified Party previously received from the Indemnifying Party.

8.2 Required Insurance. If, at any time from and after the Effective Date and prior to the execution of the Ground Leases, Developer or its employees, agent, contractors, or representatives enter onto the Premises or any other property of Owner pursuant to this Agreement, Developer shall obtain and maintain all insurance policies and coverages required to be maintained by Developer as set forth in **Exhibit F** attached hereto.

## 9. ENVIRONMENTAL MATTERS

### 9.1 Environmental Due Diligence.

9.1.1 Prior to the Closing of any Ground Lease Parcel, Developer shall have the option to order a Phase 1 Environmental Site Assessment and to undertake any required soil and/or groundwater testing, subject to the provision of Section 3.6.

9.1.2 Developer agrees that any and all information and data developed in connection with any environmental testing conducted by Developer as permitted hereunder (the "Confidential Due Diligence Information") shall be kept confidential in accordance with and subject to the provisions of Section 12.12, and further agrees that, prior to the applicable Closing, unless Owner requests that any Confidential Due Diligence Information be disclosed to Owner or to any other party, the Confidential Due Diligence Information shall not be reported or disclosed to Owner, any governmental agency (unless such reporting or disclosure by Developer is required by law), the Scope of Work Document (including the Environmental MOU), or to any other party other than to Developer's and its Affiliates' respective members, managers, employees, attorneys, prospective and actual partners, joint venturers, environmental insurers, prospective and actual lenders and any consultants or contractors engaged by Developer in connection

with the Project (or, subject to Owner Reasonable Approval, to any prospective commercial tenants of the Project) who have a need to know the Confidential Due Diligence Information in connection with the purposes contemplated under this Agreement and the applicable Ground Lease(s), and then only subject to the provisions of Section 12.12. In the event that Developer determines, after consultation with environmental counsel, that it is required by law to report or disclose Confidential Due Diligence Information to any governmental agency prior to the applicable Closing, Developer shall, in accordance with the Scope of Work Document, and to the extent permitted by applicable Laws, prior to any such disclosure, consult with Owner, provide Owner with any available information reasonably requested by Owner, and afford Owner a reasonable opportunity to review the relevant facts and circumstances and make a determination as to whether reporting is necessary and/or whether Owner will take responsibility for reporting such information to the relevant governmental agency. Developer's obligations under this Section 9.1.2 shall survive any termination of this Agreement, except that to the extent any Confidential Due Diligence Information relates specifically to any Ground Lease Parcel, Developer's obligations under this Section 9.1.2 shall not survive the Closing for such Ground Lease Parcel with respect to such Confidential Due Diligence Information.

#### 9.1.3 Environmental Contamination.

9.1.3.1 After Developer has closed on a Ground Lease, the applicable Ground Tenant shall be responsible for remediating environmental contamination on the applicable Ground Lease Parcel in accordance with the terms of the applicable Ground Lease.

9.1.3.2 If Developer's environmental diligence of the Premises discloses any soils at the Subject Premises under any Ground Lease that have been designated an EPA Regional Screening Level ("RSL") Hazard Quotient 1.0 or higher ("Premium Materials"), Owner, as landlord under the applicable Ground Lease shall reimburse Tenant in an amount equal to the sum of the applicable Developer Party's actual costs to dispose (including without limitation any additional onsite monitoring, oversight, treatment and disposal) of any soils at the Subject Premises that have been designated an RSL Hazard Quotient 1.0 or higher less the cost to dispose of such soils assuming a designation of EPA RSL Hazard Quotient of less than 1.0 (such amount, the "Premium Costs").

9.1.3.3 Owner's reimbursement of Premium Costs under an applicable Ground Lease shall be solely in the form of ground rent offsets, and shall be capped at the total of the ground rent payments due under the applicable Ground Lease, for the first five years of rent payments under only the Ground Lease applicable to the Ground Lease Parcel containing the subject Premium Materials.

9.1.3.4 Developer or the Applicable Developer Party's right to reimbursement of the Premium Costs shall be conditioned on such Developer Party, at its sole cost and expense, and in accordance with the terms of the applicable



Ground Lease, entering the Ground Lease Parcel for which reimbursement is sought into the State of Tennessee Department of Environment and Conservation (“TDEC”) Voluntary Oversight and Assistance Program (“VOAP”) and obtaining a No Further Action determination (“NFA”) from TDEC with respect to the Premium Materials for which such Developer Party seeks reimbursement of remediation costs in accordance with Section 9.1.3.2.

9.1.4 The applicable Developer Party shall act commercially reasonable and shall take into account the reasonable input of Owner in its remediation of any Premium Materials, provided that Owner shall in no event be required to remediate in such a way that restricts Owner’s use of the Subject Premises for all of the uses permitted under the Rezoning or as permitted under the applicable Ground Lease pursuant to which the applicable Developer Party is remediating such Premium Materials.

9.1.5 Brownfield Tax Credits.

9.1.5.1 Developer may, at its sole discretion and at its sole cost and expense, and in accordance with the terms of the applicable Ground Lease, enter any Ground Lease Parcel into the TDEC VOAP for the purpose of obtaining a Brownfield Voluntary Agreement and an NFA with respect to Hazardous Materials or other constituents of environmental concern at or affecting such Ground Lease Parcel.

**10. EMINENT DOMAIN**

10.1 Award Proceeds/Termination. If, prior to the Closing with respect to any Ground Lease Parcel, all or any material portion of that Ground Lease Parcel shall be the subject of a Taking, then Developer may elect to terminate this Agreement with respect to the Ground Lease Parcel affected by such Taking by giving notice thereof to Owner not later than sixty (60) days after Developer receives notice of such Taking. In the event of a termination by Developer with respect to one or more Ground Lease Parcels pursuant to the immediately preceding sentence, this Agreement shall be deemed amended to remove such Ground Lease Parcel(s) from this Agreement, including, without limitation, from the definitions of the Project and the Premises. For the purposes of this Section 10.1, a “material portion” shall mean any portion which renders the remaining portion of the Subject Premises unsuitable for the construction and development of the Subject Project proposed to be constructed on the Subject Premises in substantially the form contemplated by this Agreement including without limitation any applicable access or parking. In the event of any termination in accordance with this Section 10.1, Developer shall be entitled to a portion of any condemnation award in an amount equal to the sum of (a) the amount of out-of-pocket costs and expenses actually incurred by Developer as of the date of such termination with respect to the Subject Premises affected by such Taking, including any reasonable out-of-pocket predevelopment costs, plus (b) Developer’s costs for any Developer Infrastructure Work allocated to the Applicable Premises, as determined by Developer in good faith. Unless Developer terminates this Agreement with respect to the Ground Lease Parcel affected by such Taking (or with respect to such Ground Lease Parcel and all other Ground Lease Parcels for which a Closing has not yet occurred), the Ground Rent for each Ground Lease Parcel should be proportionately reduced to reflect the portion

of such Ground Lease Parcel affected by such Taking. This Section shall not apply with respect to any Ground Lease Parcel for which the Closing has occurred prior to the date of such Taking.

## 11. DEFAULT AND TERMINATION

### 11.1 Default .

11.1.1 The occurrence of any one or more of the following events shall constitute a “Developer Event of Default”:

(a) if (x) Developer fails to observe or perform any material covenant, condition, agreement or obligation hereunder (so long as such failure to observe or perform is not caused by the acts or omissions of any Owner Parties which constitutes a breach of this Agreement), and (y) Developer fails to cure, correct or remedy such default within thirty (30) days after the receipt of written notice thereof from Owner, describing it with reasonable specificity, unless such failure cannot with due diligence be cured within a period of thirty (30) days, in which case such failure shall not be deemed to continue if Developer proceeds promptly and with due diligence to cure the failure and uses commercially reasonable efforts to complete the curing thereof as soon as is practicable but in no event more than ninety (90) days after receipt of such written notice;

(b) if any representation or warranty of Developer set forth in this Agreement shall prove to be incorrect in any material respect as of the Effective Date, and Developer fails to cure, correct or remedy such failure to be true within thirty (30) days after the receipt of written notice thereof from Owner, unless such failure cannot with due diligence be cured within a period of thirty (30) days, in which case such failure shall not be deemed to continue if Developer proceeds promptly and with due diligence to cure the failure and uses commercially reasonable efforts to complete the curing thereof as soon as is practicable but in no event more than ninety (90) days after receipt of such written notice;

(c) If any Guarantor that is an Affiliate of Fallon defaults under a Completion Guaranty and such default continues beyond any applicable cure or grace periods set forth in such Completion Guaranty;

(d) except as otherwise provided by applicable Laws, if Developer, Fallon, or any Guarantor, shall be judicially declared bankrupt or insolvent according to law or if any assignment shall be made of the property of Developer, Fallon, any Guarantor, for the benefit of creditors, or if a receiver, guardian, conservator, trustee in bankruptcy or other similar officer shall be appointed to take charge of all or any substantial part of the property of Developer Fallon, or any Guarantor, by a court of competent jurisdiction, or if a petition shall be filed for the reorganization or liquidation

of Developer, Fallon, any Guarantor under any provisions of law now or hereafter enacted, and such proceeding is not vacated or dismissed within ninety (90) days after it is begun (in each case, other than at the request of or on behalf of the Owner), or if Developer, Fallon, or any Guarantor shall file a petition, or voluntarily submit to the filing of a petition, for such reorganization or liquidation, or for arrangements under any provisions of such laws providing a plan for a debtor to settle, satisfy or extend the time for the payment of debts.

11.1.2 Notwithstanding the foregoing to the contrary, if there shall be a Developer Event of Default pursuant to Section 11.1.1(d) and such Developer Event of Default arises out of the occurrence of any of the events listed therein solely with respect to Fallon or the Guarantor, then Developer shall have sixty (60) days from the occurrence of such event to replace Fallon or the Guarantor with a guarantor meeting the requirements of a Preapproved Guarantor hereunder or any other Person approved by Owner in Owner's reasonable discretion.

11.1.3 The occurrence of any one or more of the following events shall constitute an "Owner Event of Default":

(a) if (x) Owner fails to observe or perform any material covenant, condition, agreement or obligation hereunder (so long as such failure to observe or perform is not attributable to the acts or omissions of Developer or any of Developer's Affiliates which constitutes a breach under this Agreement) and (y) Owner fails to cure, correct or remedy such default within thirty (30) days after the receipt of written notice thereof from Developer, describing it with reasonable specificity, unless such failure cannot with due diligence be cured within a period of thirty (30) days, in which case such failure shall not be deemed to continue if Owner proceeds promptly and with due diligence to cure the failure and diligently completes the curing thereof; or

(b) except for Permitted Owner Breaches, if any representation or warranty of Owner set forth in this Agreement, or in any notice, certificate, demand, submittal or request delivered to Developer prior to Closing by Owner pursuant to this Agreement, shall prove to be incorrect in any material respect as of the time when the same shall have been made and Owner fails to cure, correct or remedy such failure to be true within thirty (30) days after the receipt of written notice thereof from Developer, unless such failure cannot with due diligence be cured within a period of thirty (30) days, in which case such failure shall not be deemed to continue if Owner proceeds promptly and with due diligence to cure the failure and diligently completes the curing thereof; and

(c) except as otherwise provided by applicable law, if Owner shall be judicially declared bankrupt or insolvent according to law or if any assignment shall be made of the property of Owner for the benefit of

creditors, or if a receiver, guardian, conservator, trustee in bankruptcy or other similar officer shall be appointed to take charge of all or any substantial part of the property of Owner by a court of competent jurisdiction, or if a petition shall be filed for the reorganization or liquidation of Owner under any provisions of law now or hereafter enacted, and such proceeding is not vacated or dismissed within ninety (90) days after it is begun, or if Owner shall file a petition for such reorganization or liquidation, or for arrangements under any provisions of such laws providing a plan for a debtor to settle, satisfy or extend the time for the payment of debts.

11.2 Termination of Agreement. Except as otherwise set forth in this Agreement, including, without limitation, Section 2.5.9 (Developer Representations), Section 2.6.13 (Owner Representations), Section 3.5.1 (Developer Title Objections), Section 3.5.2 (Additional Title Matters), Section 5.14 (Failure to Meet Development Milestones), Section 5.15 (Termination of Project); Section 6.5 (Waiver of Conditions), Section 6.6 (Failure to Close), Section 10 (Eminent Domain), and Section 11.3 (Remedies), this Agreement may be terminated only upon in a written instrument signed by Owner and Developer (each in its sole discretion). Upon any termination of this Agreement pursuant to the express provisions hereof, all obligations of the Parties under this Agreement shall cease, except for those obligations that expressly survive termination. Upon any termination of this Agreement, Developer shall assign to Owner, for no consideration, all Final Plans and Approvals related to the Public Realm Components, subject to the rights of any Institutional Lender providing construction financing in accordance with the terms of the applicable Ground Lease(s).

11.3 Remedies. In addition to the rights and remedies expressly set forth in this Agreement, the Parties shall have the following rights and remedies with respect to Events of Default under this Agreement:

(a) if a Developer Event of Default exists at any time prior to the first Closing hereunder with respect to one or more Ground Lease Parcels, Owner shall have the right to (i) terminate this Agreement in its entirety by delivering written notice thereof to Developer and (ii) seek damages from Developer for such Developer Event of Default, provided that Owner shall have no right to seek consequential damages, special damages, incidental damages, lost profits, or punitive damages;

(b) if a Developer Event of Default exists at any time following the first Closing with respect to one or more Ground Lease Parcels, then Owner shall have the right to (i) terminate this Agreement with respect to any Ground Lease Parcels with respect to which Closings have not yet occurred and (ii) seek damages from Developer for such Developer Event of Default, provided that Owner shall have no right to seek consequential damages, special damages, incidental damages, lost profits, or punitive damages;

(c) if an Owner Event of Default exists prior to the first Closing hereunder with respect to one or more Ground Lease Parcels, Developer shall have the right, as its sole and exclusive remedies, to either (i) commence an action seeking specific performance of Owner's obligations under this Agreement or (ii)(y) terminate this Agreement in its entirety and (z) seek damages from Owner for such breach in an amount not to exceed \$5,000,000.00; and

(d) if an Owner Event of Default exists any time following the first Closing with respect to one or more Ground Lease Parcels, (i) Developer shall have the right, as its sole and exclusive remedies, to either (x) commence an action seeking specific performance of Owner's obligations under this Agreement or (y) (A) terminate this Agreement with respect to any Ground Lease Parcels with respect to which Closings have not yet occurred and (B) seek damages from Owner for such breach in an amount not to exceed \$5,000,000.00, and (ii) the applicable Developer Parties shall be entitled to seek any remedies for such breach that are available to such Developer Parties, if any, as ground lessees under the Ground Leases that were previously executed.

The parties hereby waive their right to mutuality of remedies. The provisions of this Section 11.3 shall survive the termination of this Agreement.

## **12. MISCELLANEOUS**

12.1 Applicable Law; Waiver, Interpretation. This Agreement shall be governed by and construed in accordance with the laws of the State of Tennessee, without regard to conflicts of laws principles. Claims made in connection with this Agreement may only be made in and in and prosecuted in courts of competent jurisdiction in Nashville, Tennessee and each party consents to the exclusive jurisdiction of such courts and hereby waives any right to remove any such action to any other forum. The parties hereto waive a trial by jury of any and all issues arising in any action or proceeding between them or their successors or assigns under or connected with this Agreement or any of its provisions or any negotiations in connection therewith. The titles, captions, and headings of the Sections, and the Table of Contents, contained herein are for convenience only and shall not be considered in construing this Agreement. Unless otherwise expressly stated, all references in this Agreement to Sections shall be deemed to refer to the corresponding Section contained in this Agreement, as the same may be amended from time to time in accordance with the terms hereto.

12.2 No Waiver. No assent, express or implied, by either party to any breach of or default in any term, covenant or condition herein contained on the part of the other to be performed or observed shall constitute a waiver of or assent to any succeeding breach of or default in the same or any other term, covenant or condition hereof.

12.3 Notices. All notices, demands, submissions, requests, consents, approvals and other instruments required or permitted to be given pursuant to the terms hereof, shall be in writing and shall be deemed to have been properly given if (i) delivered by hand, (ii) or sent by registered or certified United States mail, postage prepaid, return receipt requested,

(iii) by nationally recognized overnight mail or courier service (with signed confirmation of receipt) or (iv) by e-mail to the following addresses, respectively:

If to Owner:

THE METROPOLITAN GOVERNMENT OF NASHVILLE  
AND DAVIDSON COUNTY  
Metropolitan Courthouse  
1 Public Square  
Nashville, Tennessee 37201  
Attention: Chief Development Officer  
Email: Bob.Mendes@nashville.gov

Metropolitan Department of Law  
1 Public Square, Suite 108  
Nashville, Tennessee 37201  
Attn.: Department of Law  
Email: tom.cross@nashville.gov

with a copy to:

Greenberg Traurig, LLP  
1000 Louisiana Street, Suite 6700  
Houston, TX 77002  
Attention: Denis Braham  
Email: Denis.Braham@gtlaw.com

If to Developer:

c/o The Fallon Company LLC  
1222 Demonbreun Street, Suite 1210  
Nashville, Tennessee  
Attention: Benjamin Farrer  
Email: bfarrer@falloncompany.com

with copies to:

The Fallon Company LLC  
ONE Marina Park Drive, 14<sup>th</sup> Floor  
Boston, Massachusetts 02201  
Attention: Brian M. Awe  
Email: bawe@falloncompany.com

DLA Piper LLP (US)  
33 Arch Street, 26<sup>th</sup> Floor  
Boston, Massachusetts 02110  
Attention: John E. Rattigan, Jr., Esq.  
Oriana R. Montani, Esq.  
Email: john.rattigan@us.dlapiper.com  
oriana.montani@us.dlapiper.com

And to:

Bradley, Arant, Boult, Cummings LLP  
ONE 22 ONE  
1221 Broadway, Suite 2400  
Nashville, Tennessee 37203  
Attention: J. Thomas Trent, Jr. Esq.  
Jim Murphy, Esq.  
Email: ttrent@bradley.com  
jmurphy@bradley.com

or to such other addresses as may from time to time be specified in writing by any party hereto. Any notices or other communications under this Agreement must be in writing, and shall be deemed duly given or made at the time and on the date when received by e-mail transmittal of pdf files or similar electronic means or when personally delivered as shown on a receipt therefor (which shall include delivery by a nationally recognized overnight delivery service) to the address for each Party set forth above or when delivery is refused. Any Party, by written notice to the other in the manner herein provided, may designate an address different from that set forth below. Notwithstanding the foregoing to the contrary, any notice received by e-mail or other electronic means after 6:00 pm CT shall be deemed given or made on the next Business Day. Any notice to be given by any party hereto may be given by the counsel for such Party.

12.4 Partial Invalidity. If any term or provision of this Agreement or the application thereof to any Person or circumstances shall, to any extent, be invalid or unenforceable, the remainder of this Agreement, or the application of such term or provision to Persons or circumstances other than those as to which it is held invalid or unenforceable, shall not be affected thereby, and each term and provision of this Agreement shall be valid and be enforced to the fullest extent permitted by law.

12.5 Entire Agreement; Amendment. This Agreement and the exhibits attached hereto include the entire agreement of the parties with respect to the construction of the Project and the Developer Infrastructure Work. No change, amendment or addition to this Agreement shall be effective unless in writing signed by all parties.

12.6 Compliance with Laws. With respect to all actions taken hereunder, each Party shall comply with all applicable Laws.

12.7 Relationship of the Parties. Until execution and delivery of the Ground Leases, nothing contained herein shall be construed as creating any possessory rights in Developer as to Ground Lease Parcels. Furthermore, nothing in this Agreement creates the relationship of principal and agent or of partnership or of joint venture or, of landlord and tenant, between Owner and Developer, it being understood and agreed that no provision contained herein, nor any acts of the parties hereto, shall be deemed to create any such relationship between the parties.

12.8 Confidentiality. The Parties recognize that each Party may be required to deliver certain proprietary information to the other under the terms of this Agreement or may have already delivered certain proprietary information to the other prior to the date hereof. Each party, upon receipt from the other party of any document designated as “Confidential” or “Proprietary” shall use reasonable efforts, subject to compliance with all applicable Laws, including (without limitation) the Tennessee Public Records Act, to protect the confidentiality of any such document and the information contained therein, but Landlord makes (and shall not be deemed to have made) any representation or warranty that such actions will prevent such information from becoming publicly available.

12.8.1 Except as otherwise required by applicable Laws, including (without limitation) the Tennessee Public Records Act, neither Party shall divulge the other Party’s Confidential Information (as hereinafter defined) concerning this Agreement, the applicable Ground Lease(s), the Project, the Premises, the other Party or its Affiliates, any land owned by such Party, any real estate development plans of such Party or its Affiliates and any permitting processes and approvals related to, and the present or projected operations or affairs of, any of the foregoing, to anyone without the other Party’s prior written consent (except for Confidential Due Diligence Information where disclosure to a governmental agency is required by law prior to the Closing and is addressed in accordance with Section 9.1.2 of this Agreement prior to any such disclosure); provided, however, that either Party may without the other Party’s consent share Confidential Information with its Affiliates and their respective employees, officers, directors, members, managers, attorneys, principals, agents, consultants or contractors who need to receive such information in order to perform services or work relating to this Agreement or the Project, or to prospective or actual partners, joint venturers, environmental insurers or lenders (or, with respect to Confidential Due Diligence Information only, in accordance with the prospective tenant review protocol to be established, to any prospective commercial tenants of the Project), or to other Persons who have executed confidentiality agreements with either Party with respect to such Party’s Confidential Information; and provided further, that the disclosing Party enforces compliance by each such Person receiving the other Party’s Confidential Information with the confidentiality requirements of this Section 12.8 and that the disclosing Party informs each such Person receiving Confidential Information of the confidential nature of such Confidential Information and directs each such Person receiving the Confidential Information to treat the Confidential Information confidentially and not to use it other than in connection with this Agreement, the applicable Ground Lease(s), the Project or the Developer Infrastructure Work. The term “Confidential Information” as used herein shall mean all knowledge, information, data, materials, trade secrets and work product gained, obtained, derived, produced, generated or otherwise acquired by either Party and/or any of its employees, officers, directors, principals, agents, consultants or contractors, with respect to this Agreement, the applicable Ground Lease(s), the Project, the Premises, the other Party or its Affiliates, any land owned by Owner, any real estate development plans and/or any permitting processes and approvals related to, and the present or projected operations or affairs of, any of the foregoing, and shall include, without limitation, all Confidential Due Diligence Information. The term “Confidential Information” shall not include information that (i) becomes generally available to the public but not due to actions or



omissions of the other Party or any of its employees, officers, directors, principals, agents, consultants or contractors (collectively, such Party's "Representatives") in violation of this Section 12.8, (ii) information already lawfully in the possession of such Party or its Representatives from a source not known by such Person to be bound by an obligation of confidentiality to the other Party with respect to such information, (iii) information that becomes available to such Party or its Representatives from a source not known by such Person to be bound by an obligation of confidentiality to the other Party with respect to such information, and (iv) information independently developed by a Party or its Representatives without reference to or use of the Confidential Information. Except as otherwise required by applicable Laws, including (without limitation) the Tennessee Public Records Act, no Party shall at any time disclose, permit the disclosure of, release, disseminate, or transfer, whether orally or by any other means, any part of the other Party's Confidential Information to any other Person of whatever kind or nature, including without limitation a corporation, government, or individual, without the express prior written consent of an authorized representative of such Party (except for Confidential Due Diligence Information where disclosure to a governmental agency is required by law prior to the Closing and is addressed in accordance with Section 9.1.2 of this Agreement prior to any such disclosure). Except as otherwise expressly provided in this Agreement or by applicable Laws, including (without limitation) the Tennessee Public Records Act, each Party shall return to the other Party or destroy any and all written Confidential Information pertaining to the other Party, and all copies made of such items, upon request from the other Party. Each Party shall take such measures to maintain the confidentiality of the other Party's Confidential Information that such Party uses to protect its own confidential information. Owner reserves the right to retain and control all of Owner's Confidential Information relating to Owner, including, without limitation, the timing of the release of any such information and the form and content of the same. In the event that a Party is involved in adversarial judicial proceedings, any disclosures made by such Party to the extent necessary to comply with applicable Laws or in connection with its defense in such judicial proceeding shall not be considered a disclosure in violation of this provision, provided that such Party complies with the provisions of Section 12.8. Notwithstanding anything to the contrary herein, to the extent that any of Developer's Confidential Information could become public information by virtue of delivering such information to Owner, Developer shall be entitled to provide such information to Owner by (a) making such information available to Owner for review, (b) providing such information to Owner via an online repository or share file, or (c) any other reasonable means of providing information that could be reasonably anticipated to prevent the information from becoming publicly available pursuant to the Tennessee Public Records Act or any other applicable Law.

12.8.2 To the extent permitted by applicable Laws, each Party shall immediately notify the other Party of any court order or subpoena requiring disclosure of any Confidential Information of the other Party and shall cooperate (at such other Party's sole expense) with legal counsel for such other Party in the appeal or challenge of any such order or subpoena. Either Party may disclose the other Party's Confidential Information required to be disclosed pursuant to court order or subpoena, only (to the extent permitted by applicable Laws) after such Party, as

receiver, has exhausted any lawful and timely appeal or challenge that such Party, as receiver, elects to file or make in connection with such court order or subpoena.

12.8.3 Each Party acknowledges that money damages may not be a sufficient remedy for any violation of the terms of this Section 12.8 and accordingly any aggrieved Party will be entitled to specific performance and injunctive relief as remedies for any violation of this Section 12.8. These remedies will not be exclusive remedies but will be in addition to all other remedies available at law or equity.

12.8.4 The provisions of this Section 12.8 shall survive for a period of four (4) years following any termination of this Agreement in its entirety.

12.9 Time of the Essence. Time shall be of the essence hereof. For purposes of this Agreement, whenever the date for performance of any obligation hereunder (as such date may be extended by either Party pursuant to any applicable extension right provided in this Agreement) falls on a day that is not a Business Day, such obligation shall be performed by not later than the next following Business Day.

12.10 Intentionally Omitted.

12.11 Remedies Cumulative. Except as otherwise expressly provided in this Agreement, each right and remedy of either party provided for in this Agreement shall be cumulative and shall be in addition to every other right or remedy provided for in this Agreement (except as otherwise expressly limited by the terms of this Agreement), and the exercise or beginning of the exercise by a Party of any one or more of the rights or remedies provided for in this Agreement (except as otherwise expressly limited by the terms of this Agreement), shall not preclude the simultaneous or later exercise by such Party of any or all other rights or remedies provided for in this Agreement (except as otherwise expressly limited by the terms of this Agreement).

12.12 Approval.

12.12.1 Unless otherwise expressly provided in this Agreement, wherever this Agreement requires the consent, approval or authorization of or from a Party, such Party shall have the right to grant or to withhold the same in its sole and absolute discretion. No Party shall have any claim, and hereby waives the right to any claim, against the other Party for money damages by reason of any refusal, withholding or delaying by such other Party of any consent, approval or statement of satisfaction, and, in such event, the only remedies therefor shall be an action for specific performance or injunction to enforce any such requirement. Any approval rights of Owner, whether or not subject to Owner Reasonable Approval, shall be subject solely to the review and approval of Appropriate Owner Staff. For avoidance of doubt, Developer's receipt of Owner Reasonable Approval shall in no event constitute any approval required under applicable Law (including without limitation zoning or other Approvals).

12.12.2 Owner Reasonable Approval:

12.12.2.1 With respect to any matter for which “Owner Reasonable Approval” or “Owner’s Reasonable Approval” is required in accordance with the terms of this Agreement or any of the Exhibits or Schedules hereto (including any matters requiring Owner Reasonable Approval under the Scope of Work Document attached hereto as **Exhibit D**) (an “Approval Matter”), approval of such Approval Matter shall be undertaken by Appropriate Owner Staff and shall not be unreasonably withheld, delayed or conditioned. Any dispute between Developer and Owner regarding the reasonableness of Owner’s withholding, delay or conditioning of its approval with respect to any Approval Matter shall be resolved pursuant to the Expedited Dispute Resolution Procedure. In connection with any Approval Matter, unless a specific Owner approval period with respect to such Approval Matter is expressly set forth in another provision of this Agreement, including the Scope of Work Document attached hereto as **Exhibit D** (in which case such other express provision shall govern and control with respect to Owner’s time to approve such Approval Matter), Developer shall submit to Owner a written request for approval of such Approval Matter (an “Initial Approval Request”), and unless a specific Owner approval period with respect to such Approval Matter is expressly set forth in another provision of this Agreement, including the Scope of Work Document attached hereto as **Exhibit D** (in which case such other express provision shall govern and control with respect to Owner’s time to approve such Approval Matter), if Owner fails to disapprove of such Approval Matter within ten (10) days after Owner’s receipt of such Initial Approval Request, Developer shall be entitled to deliver to Owner a second request for Owner’s approval of such Approval Matter (a “Second Approval Request”). Owner Reasonable Approval shall be deemed to have been granted with respect to any Approval Matter if such Approval Matter is not disapproved in writing by Owner within ten (10) days after Owner’s receipt of a Second Approval Request.

12.12.2.2 Any applicable deadlines to which Developer is subject under this Agreement shall be deemed extended (i) by the period during which, pursuant to the Expedited Dispute Resolution Procedure, the Senior Executives are discussing a Deadlock (as defined in **Schedule 1.B**) with respect to any Approval Matter, and (ii) if Owner is determined, pursuant to a Final Court Determination, to have unreasonably withheld, delayed or conditioned its approval, by the period of delay resulting from such unreasonable withholding, delaying or conditioning of such approval by Owner.

12.12.2.3 Each Initial Approval Request submitted pursuant to this Section 12.12.2.3 shall include, in bold, conspicuous large font at the top of the front page, the following language: “THIS IS AN INITIAL APPROVAL REQUEST FOR OWNER REASONABLE APPROVAL UNDER SECTION [ ] OF THE DEVELOPMENT AGREEMENT.” Any Second Approval Request submitted pursuant to this Section 12.12.2.3 shall include the following language: “THIS IS A SECOND APPROVAL REQUEST FOR OWNER REASONABLE APPROVAL UNDER SECTION [ ] OF THE DEVELOPMENT AGREEMENT. OWNER’S FAILURE TO RESPOND TO THIS SECOND APPROVAL REQUEST WITHIN TEN (10) DAYS SHALL BE

DEEMED OWNER'S APPROVAL OF THE APPROVAL MATTER REFERENCED HEREIN.”

12.13 Bind and Inure. The covenants and agreements contained in this Agreement shall bind and inure to the benefit of Owner, its permitted successors and assign, and Developer, and its permitted successors and assigns. Without limiting the generality of the foregoing, any covenant or agreement in this Agreement that pertains to any Ground Lease Parcel and/or purports to confer rights upon the Ground Tenant under any Ground Lease may be enforced by Developer on behalf of the applicable Ground Tenant.

12.14 Limitation of Liability. Notwithstanding anything to the contrary contained in this Agreement, but without limitation of any Party's equitable rights and remedies, except as otherwise provided in any separate guaranty, indemnification agreement, or other instrument executed and delivered to either Party in connection with this Agreement or the Premises (including, without limitation, the Guaranty), no direct or indirect member, manager, partner, owner, shareholder, director, officer, employee, trustee, agent or representative in or of a Party or any of its Affiliates (each, other than a Party, a “Nonrecourse Party”) shall have any personal liability in any manner or to any extent under this Agreement and no Party nor any Person claiming by, through or under such Party shall have any recourse to any assets of a Nonrecourse Party. The limitation of liability provided in this Section 12.14 is in addition to, and not in limitation of, any limitation on liability applicable to a Nonrecourse Party provided by law or by this Agreement or any other contract, agreement or instrument.

12.15 No Advertisement. (i) Developer shall not, without Owner's prior written approval, refer to Owner in any advertising, letterheads, bills, invoices or in other printed materials and (ii) Owner shall not, without Developer's prior written approval, refer to Developer, any of its Affiliates or “Fallon” in any advertising, letterheads, bills, invoices or in other printed materials.

12.16 When Agreement Becomes Binding; Counterparts; Electronic Signatures. This Agreement shall become effective and binding only upon the execution and delivery hereof by both Owner and Developer. This Agreement may be executed in two or more counterparts, and by each or either of the parties in separate counterparts, each of which shall be deemed an original, but all of which together shall constitute one and the same instrument. Delivery by fax or by electronic mail file attachments of any executed counterpart of this Agreement will be deemed the equivalent of the delivery of the original executed instrument.

12.17 Survival. As provided herein, Sections 8.1.1, 8.1.2, 9.1.2, 11.3, and 12.8 by their express terms shall survive the Closings and/or any termination of this Agreement.

12.18 Memorandum of Agreement. Owner and Developer agree to execute, deliver and record with the Register the Memorandum of Agreement in the form of **Exhibit I** attached hereto at Developer's sole cost and expense on or immediately following the Effective Date. Upon the any termination of this Agreement, in whole or in part, Owner shall deliver to Developer a notice of termination of memorandum agreement in form and substance reasonably acceptable to both

parties and, unless Developer has delivered to Owner written notice that Developer disputes whether the Agreement has been validly terminated in whole or in part, Developer shall, within thirty (30) days of receipt thereof, execute and deliver the same to Owner for Owner's execution and recordation with the Register at Owner's sole cost. If Developer fails to deliver an executed termination of memorandum of agreement or any dispute thereof as set forth above, and Owner sends a second notice to Developer after such initial thirty (30)-day period and Developer fails to deliver such executed termination of memorandum of lease or dispute thereof within seven (7) days after receipt of such second notice, Owner may unilaterally record a memorandum of termination in the Register, which third parties may rely upon as conclusive evidence of the termination of this Agreement. Such second notice shall include the following language in bold and capitalized text: "THIS IS A SECOND REQUEST FOR DEVELOPER'S EXECUTION OF THE TERMINATION OF MEMORANDUM OF AGREEMENT UNDER SECTION 12.18 OF THE MASTER DEVELOPMENT AGREEMENT."

12.19 No Recording. Neither Party may record this Agreement without the prior written consent of the other Party.

12.20 Incorporation of Exhibits and Schedules. The Exhibits and Schedules identified in this Agreement are incorporated herein by reference and made a part hereof.

### **13. LIMITED GUARANTY FROM FALLON**

Fallon hereby guarantees the prompt and full payment and performance of all obligations of Developer under this Agreement. Fallon's obligations under this Section 13 shall continue unaffected by any assignment of this Agreement or transfer of legal or beneficial ownership in Developer.

[Signatures on next page]

EXECUTED under seal as of the day and year first above written.

OWNER:

THE METROPOLITAN GOVERNMENT  
OF NASHVILLE AND DAVIDSON  
COUNTY

ATTEST:

By: \_\_\_\_\_  
Freddie O'Connell  
Metropolitan Mayor

By: \_\_\_\_\_  
Metropolitan Clerk

APPROVED AS TO FORM AND  
LEGALITY:

\_\_\_\_\_  
Director of Law

DEVELOPER:

TFC NASHVILLE DEVELOPMENT LLC

By: \_\_\_\_\_  
Name: Brian M. Awe  
Title: President

**JOINDER OF FALLON**

The undersigned has executed this Agreement solely to confirm its agreements set forth in Section 13 of this Agreement.

THE FALLON COMPANY LLC, a  
Massachusetts limited liability company

By: \_\_\_\_\_

Name: \_\_\_\_\_

Title: \_\_\_\_\_

## **Schedule 1.A**

### Expedited Dispute Resolution Procedure

If Owner withholds, delays or conditions its approval of any Approval Matter requiring Owner Reasonable Approval under the Development Agreement to which this Schedule 1.A is annexed, then a “Deadlock” shall be deemed to have occurred, which Deadlock shall be subject to the procedures set forth in this Schedule 1.A.

1. Following the occurrence of a Deadlock, Developer may deliver a written notice to Owner (a “Deadlock Notice”) pursuant to which Developer (A) notifies Owner that a Deadlock has occurred, (B) identifies the Approval Matter giving rise to such Deadlock (the “Deadlock Matter”), and (C) describes in reasonable detail Developer’s final proposal with respect to such Deadlock Matter, which, if agreed to by Owner, would resolve the Deadlock (the “Deadlock Resolution Proposal”).
2. If Owner does not agree to the Deadlock Resolution Proposal as described in the Deadlock Notice within seven (7) Business Days following Owner’s receipt of the Deadlock Notice containing such Deadlock Resolution Proposal (the “First Resolution Deadline”), then the Parties shall refer the Deadlock Matter to their respective Senior Executives, and the Parties shall cause the Senior Executives to meet at least once (in person or ZOOM meeting or similar videoconference) within seven (7) Business Days after the First Resolution Deadline and negotiate in good faith to resolve the Deadlock. In the event that a Party designates a designee as its Senior Executive, such designee must have familiarity with the Project and the issue that is the subject of the dispute, and the authority to resolve the Deadlock (on terms other than such Party’s position).
3. If the Senior Executives fail to resolve the Deadlock to the Parties’ mutual satisfaction by the date (the “Second Resolution Deadline”) that is seven (7) Business Days after the First Resolution Deadline, then, either Party may pursue any and all rights and remedies that it might otherwise have under this Agreement.



**Schedule 1.B**  
Senior Executives

Owner Senior Executives

1. The Mayor of the Metropolitan Government of Nashville and Davidson County, Tennessee or any designee of the Mayor so long as such designee either has the title of Director or otherwise reports directly to the Mayor, and has been authorized by the Mayor to make decisions regarding the Campus; and
2. Following an assignment of this Agreement to the East Bank Authority, the Chief Executive Officer of the East Bank Authority

Developer Senior Executive

1. Joseph F. Fallon
2. Michael J. Fallon
3. Brian M. Awe

### **Schedule 3.5.5**

#### Required Endorsements

1. ALTA 17-06 (Direct Access)
2. ALTA 17.2-06 (Utility Access)
3. ALTA 9.01-06 (Unimproved Land)
4. ALTA 9.9-06 (Private Rights)
5. ALTA 8.2-6 (Commercial Environmental Protection Lien)
6. ALTA 26-06 (Subdivision), if applicable as of the Closing Date
7. ALTA 13.1-06 (Leasehold)
8. ALTA 18.1-06 (Multiple Tax Parcel), if applicable as of the Closing Date
9. ALTA 39-06 - (Policy Authentication)
10. ALTA 28.1-061 (Encroachments - Boundaries and Easements) (04-02-12), if applicable as of the Closing Date
11. Waiver of Arbitration

---

<sup>1</sup> Note: ALTA 28.1-06 may include exceptions for any Developer Party buildings or improvements.

**Schedule 4.1.1.1**

Base Value per Rentable Square Foot  
(to be attached after MDA Execution but not later than [\_\_\_\_\_, 2024])

## Schedule 4.1.1.2

### Base Rent Calculation Methodology

#### OVERVIEW:

Base Rent shall be an annual amount paid monthly commencing on the Rent Commencement Date (as defined in the Ground Lease) calculated by multiplying the number of rentable square feet (or keys) of each use constructed on a Parcel, times a rental value for each use on a Parcel, times the applicable lease yield. The base rental value for each use shall be determined by an appraisal performed promptly following the later to occur of the execution of this Agreement and completion of the Rezoning. The application of such values to particular buildings will be determined at the time of execution of the Ground Lease, subject to escalation based on change in the CPI (as defined in the Ground Leases) from the initial calculation of the values to the time of execution of the applicable Ground Lease except as otherwise described below. The foregoing is described with more specificity below.

#### BASE VALUE DETERMINATION (ALL USES):

Promptly after the later to occur of the execution of this Agreement and completion of the Rezoning, the parties will engage a mutually-agreed upon appraiser to determine the value of the land as of such time with an appraisal of the fair market value of the land comprising the IDA Land as a whole, determined as if the land will be owned in fee simple and will be developed for each of the uses permitted in the IDA Land and otherwise in accordance with the Appraisal Instructions set forth below. Such fair market value will be expressed by the Appraiser as a per rentable square foot amount (or for hotels, a per key amount) for each applicable use on each parcel within the IDA Land. Such appraisal will identify a single per square foot (or per key) amount for each of the following uses: high-rise residential (eight stories or more); low-rise residential (seven stories or less); affordable residential (assumed to be financed with LIHTC and other customary local capital/grant sources); full-service hotel; limited-service hotel; retail; office; and any other applicable commercial use. Such per unit amounts will be called the “Base Value” for each applicable use.

If either Party does not agree with the results of the appraisal, [*NTD: To include three appraiser method for disagreement over appraisal results.*].

#### BASE RENT DETERMINATION (RESIDENTIAL/RETAIL/PARCEL B):

For any residential or retail uses, or any use located on Parcel B, Base Rent under the Ground Lease will be determined as follows:

After Developer has delivered a Closing Notice to Owner for any applicable Ground Lease Parcel, the Base Value for each use to be developed on the applicable Ground Lease Parcel will be adjusted to take into account changes in the CPI from the date of the appraisal to the date which is sixty (60) days prior to then-scheduled Closing Date (as the same may be extended in

accordance with this Agreement) for such Ground Lease Parcel (such value, the “Adjusted Base Value”).

The Adjusted Base Value will be multiplied by the number of rentable square feet or, with respect to hotel uses on Parcel B, keys in the building(s) to be constructed pursuant to such Parcel Ground Lease for each use (the product of such equation is referred to herein as the “Total Rent Value”).

The Total Rent Value will be multiplied by a lease yield of 4.5% for any non-residential use, or 4% for any residential use, allocated according to the respective rentable square feet of residential use and non-residential use on the specific Parcel (if applicable), and the product of such equation is the “Base Rent” under the applicable Ground Lease.

#### BASE RENT DETERMINATION (HOTEL/OFFICE OTHER THAN PARCEL B):

For any hotel or office use, unless located on Parcel B, Base Rent under the Ground Lease will be determined as follows:

After Developer has delivered a Closing Notice to Owner for any applicable Ground Lease Parcel for hotel or office use (other than any Hotel or Office Project Component located on Parcel B), the Base Value for each such Parcel Ground Lease will be adjusted as follows to determine the Adjusted Base Value:

- (a) From the Effective Date through the 8<sup>th</sup> anniversary of the Effective Date: The Base Value for the applicable Ground Lease will be adjusted to take into account changes in the CPI from the Effective Date to the date which is sixty (60) days prior to then-scheduled Closing Date (as the same may be extended in accordance with this Agreement) for such Ground Lease Parcel.
- (b) From the 8<sup>th</sup> anniversary of the Effective Date through the 15<sup>th</sup> anniversary of the Effective Date: the Base Value for the applicable Ground Lease will be adjusted to take into account changes in the CPI plus 1% annually to the date which is sixty (60) prior to the applicable Ground Lease Closing Date (as the same may be extended in accordance with this Agreement).
- (c) On the 15<sup>th</sup> anniversary of the Effective Date: there will be a reappraisal for each applicable use on each non ground leased Parcel or portion thereof within the IDA Land using the Appraisal Instructions set forth below to reset the Base Value for such uses going forward, provided that if Excusable Delay has occurred, such reappraisal will be delayed for a period commensurate with the period in which the Excusable Delay delayed Developer’s performance under this Agreement. For any Hotel or Office Project Component Ground Lease Closing occurring after any such reappraisal, the Adjusted Base Value for such Ground Lease Parcel will be adjusted to take into account changes in the CPI from the date of such reappraisal to the date which is sixty (60) days prior to then-scheduled Closing Date (as the same may be extended in accordance with this Agreement) for such applicable Ground Lease Parcel.
- (d) On and after the 20<sup>th</sup> anniversary (regardless of the occurrence of Excusable Delay): On the 20<sup>th</sup> anniversary of the Effective Date (regardless of whether Developer has delivered a Closing Notice but only if the Base Value has not previously been reset pursuant to (c) above), there will be a reappraisal for each applicable use on each undeveloped parcel or

portion thereof within the IDA using the Appraisal Instructions set forth below to reset the Base Value for such uses going forward. For any Hotel or Office Project Component Ground Lease Closing occurring after any such reappraisal, the Adjusted Base Value for will be adjusted to take into account changes in the CPI from the date of such reappraisal to the date which is sixty (60) days prior to then-scheduled Closing Date (as the same may be extended in accordance with this Agreement) for any applicable Ground Lease Parcel.

- (e) If the reappraisal has been delayed for Excusable Delay pursuant to (c) above, from the 15<sup>th</sup> anniversary to the Effective Date through the 20<sup>th</sup> anniversary of the Effective Date, during the period of Excusable Delay prior to reappraisal, the Base Value for the applicable Ground Lease will be adjusted to take into account changes in the CPI plus 2% as determined on the date which is sixty (60) prior to the applicable Ground Lease Closing Date (as the same may be extended in accordance with this Agreement).

The Adjusted Base Value will be multiplied by the number of rentable square feet or, with respect to hotel uses, keys in the building(s) to be constructed pursuant to such Parcel Ground Lease for each use (the product of such equation is referred to herein as the “Total Rent Value”). The Total Rent Value will be multiplied by a lease yield of 4.5% for any non-residential use, or 4% for any residential use, allocated according to the respective rentable square feet of residential use and non-residential use on the specific Parcel (if applicable), and the product of such equation is the Base Rent under the applicable Ground Lease.

#### Appraisal Instructions:

1. The Appraiser will determine the fair market value of the land comprising the IDA Land as a whole, determined as if the land will be owned in fee simple, and will be developed for each of the uses permitted in the IDA Land. Such fair market value will be expressed by the Appraiser as a per rentable square foot amount (or for hotels, a per key amount) for each applicable use on each parcel within the IDA Land. Such appraisal will identify a single per square foot (or per key) amount for each of the following uses: high-rise residential (eight stories or more); low-rise residential (seven stories or less); affordable residential use (assumed to be financed with LIHTC and other customary local capital/grant sources); full-service hotel; limited-service hotel; retail; office; and any other applicable commercial use. Such per unit amounts shall be the “IDA Fee Simple Land Values” for each applicable use.
2. The Appraiser will then make adjustments to the IDA Fee Simple Land Values to take into account the characteristics of the individual Parcels, by calculating adjustments to the per rentable square foot amount (or for hotels, per key amounts) to reflect each of the following matters, to the extent applicable to the Parcel:
  - a. Zoning limitations or ground lease restrictions applicable to the Parcel, including height restrictions, use provisions and any other matters affecting value.
  - b. Environmental conditions at the property, including clean-up and compliance costs as well as any premium costs (in excess of ordinary soil removal costs) for soil disposal assuming a proposed development of the parcel which requires excavation for an underground garage on substantially all of the property, but in each case excluding Owner’s reimbursement obligation for Premium Costs.
  - c. Restrictions or obligations under the applicable title documents and other agreements: Campus Operations and Use Agreement, any declarations, easements, or similar documents and title matters which impose obligations on the development or use of the parcel or require contribution to the maintenance of public or publicly accessible improvements in the IDA Land.

- d. Infrastructure elements required to be funded by Developer or the tenant of such Parcel as defined in the Scope of Work Document and that the tenant is not otherwise being reimbursed for through other public financing mechanisms (including hard, soft, and financing costs to reflect the cost of upfront capital).
  - e. In the case of a residential parcel or use, any affordable housing obligations attributable to such parcel or use.
3. The Appraiser will set out the IDA Fee Simple Land Values for each applicable use and will list separately the adjustments to IDA Fee Simple Land Values, as applicable, the items listed in 2(a)-2(f) above to derive the Base Values.

**Schedule 5.1.1.1**

Provisions Relating to Residential Project Component (collectively, the “Residential Component Milestones”)

Measure	Requirement
Minimum Residential Units	Not fewer than 1,550 Units (including all IDA Parcels)
Minimum Residential Buildings	Not fewer than 5 Residential Buildings
Income Restricted Residential Units	Not fewer than 695 Income Restricted Residential Units (in the aggregate within all Market Residential Buildings and Income Restricted Residential Buildings)
Residential Buildings with all Residential Units being Income Restricted Residential Units (“ <u>Income Restricted Residential Building</u> ”)	<p>Not fewer than 2 Income Restricted Residential Buildings with a minimum of 600 Residential Units in the aggregate.</p> <p>Two-thirds of the Residential Units in each Income Restricted Residential Building are reserved for income level of less than or equal to 60% of the Area Median Income; provided that Ground Tenant will reserve 25% of units for Housing Choice or Project based Vouchers, and so long as such programs are in place and available. Ground Tenant will use good faith efforts to stay in/re-enroll the programs upon any expiration.</p> <p>One-third of the Residential Units in each Income Restricted Residential Building are reserved for income level of greater than 60% but less than or equal to 80% of the Area Median Income.</p>
Minimum Income Restricted Residential Units in Residential Buildings that are not Income Restricted Residential Buildings (“ <u>Market Buildings</u> ”)	<p>A minimum of 10% of Residential Units in Market Buildings, will be reserved as Income Restricted Residential Units.</p> <p>Income Restricted Residential Units in Market Buildings are reserved for income level of less than or equal to 80% of the Area Median Income.</p>
Affordability Requirements	<p>The applicable Ground Tenant shall provide Owner with an affirmative marketing plan for the Income Restricted Residential Units. All Income Restricted Residential Units shall be income restricted for the Term of the Ground Lease.</p> <p>The applicable Ground Tenant shall not adjust the rents of tenants of Income Restricted Residential Units during the term of such tenant’s</p>



lease unless the tenant has a voucher or the applicable Ground Tenant is utilizing project-based vouchers, where, in either instance, the voucher subsidy would satisfy the difference in monthly rent and the tenant's portion of the monthly rent would remain the same.

For tenants of Income Restricted Residential Units within Market Buildings, if the tenant's income has increased above the maximum income level described above, at the end of the lease term the tenant may renew the lease and the applicable Ground Tenant may charge such tenant market rate rent (as established by such applicable Ground Tenant). In the event of the foregoing, the next available comparable Residential Unit shall be designated as income restricted and leased to a tenant meeting the income standards above for Income Restricted Residential Units in Market Buildings.

The processes used for the Barnes Fund and Mixed Income PILOT programs shall be used to determine tenant income eligibility for Income Restricted Residential Units.

The applicable Ground Tenant shall accept Housing Choice Vouchers for Income Restricted Residential Units if the applicant is otherwise eligible, unless the applicable Ground Tenant has secured Project-based vouchers.

### **Schedule 5.1.1.2**

#### Provisions Relating to Office Project Component (the “Office Component Milestone”)

For a period commencing on the Effective Date and continuing for ten (10) years (such ten-year period, the “Office Period”), (1) Developer shall not construct a permanent building on Parcel G-2 for any primary uses other than office use and (2) Developer shall hire a broker to actively market Parcel G-2 as and when appropriate as determined by the Developer and the broker. If Developer (1) is unable to secure an office tenant on market terms for Parcel G-2 during the Office Period or (2) is able to secure an office tenant for another parcel within the IDA during the Office Period, then Parcel G-2 may thereafter be developed for another use (other than a Prohibited Use under the Ground Lease), and if the parcel is developed as a hotel, such hotel shall not count toward the Hotel Maximum.

**Schedule 5.1.1.3**

Provisions Relating to Hotel Project Component

Measure	Requirement
Maximum Hotels (Excluding Parcel B)	3 Hotels*

\* Hotel uses on Parcel B or permitted in accordance with Schedule 5.1.1.2 shall not be counted toward the Hotel Maximum and shall be in addition to the Hotel Maximum.

### **Schedule 5.13.3**

#### Diversity, Equity & Inclusion Commitments

##### **General SMWBE Goals**

- The Fallon Company – together with our partners and co-developers Pillars Development and Holladay Ventures – are committed to a robust diversity and inclusion program that sets a new market standard.
- We will look to maximize the participation of small business enterprises and minority and woman owned business enterprises (SMWBEs) and will encourage our consultants to do the same. We will explore numerous solutions to meet or exceed diversity and inclusion goals in the design, development, construction, and operation phases of the project.
- We pride ourselves on being a leader to advance DE&I in the real estate industry. This commitment extends from hiring diverse project teams, to workforce development initiatives, to our equity partnerships. As a key pillar to our philosophy, we make a concerted effort to provide meaningful investment opportunities dedicated to minority-owned firms, having done so successfully on multiple recent projects.
- Our DE&I strategy includes attacking the inequities at their root, investing in young people while also involving already-established minority and women-owned firms in our projects to provide immediate impact.

##### **Design Consultant SMWBE Target:**

- 25% of design consultants.

##### **Construction SMWBE Target:**

- 30% of construction contracts.
- General Contractor to additionally implement the following five-phase process:
  - Community Outreach: Develop relationships with primes, first-tier, and second-tier contactors and suppliers to position SMWBE firms to win work.
  - Preconstruction Phase: Identify strategic bid packages to attract SMWBE firms and provides physical and digital plans for convenience. Inform non-SMWBE firms that a portion of their selection will depend on their utilization of SMWBE firms in their subcontracting plans.
  - Procurement Phase: Contact SMWBE vendors to participate in preliminary bid meetings to address concerns, ensuring SMWBE firms are prequalified to work on the project.
  - Operations Support and Tracking: Maintain continuous communication with SMWBE firms to identify those who require additional support and assistance which maximizes SMWBDE growth and profitability. Report SMWBE awards and contractual commitments on a monthly basis to ensure successful achievement in meeting the project goals.

- Post-Project Evaluation: Conduct an in-depth, post-project review with SMWBE firms to solicit feedback from team members, set foundation for continued partnerships, and ensure continued improvement of the processes.

**Development Partner SMWBE Target:**

- Provide meaningful investment and equity opportunities dedicated to SMWBE firms, including Pillars Development (MBE) and Holladay Ventures (SBE).

**Workforce Development Project:**

Fallon shall participate with training, apprenticeship, and placement programs. In an effort to create job opportunities for local Davidson County residents, Fallon shall leverage partnerships with local educational institutions and training providers, and community and state agencies to grow a job-ready workforce. Awarded trade partners will be aware of and expected to participate in workforce development (WFD) programs.

Fallon shall require its construction manager(s) to implement this WFD program:

**Construction's Workforce Development Program (WFD):**

- WFD Goals:
  - Create individual economic independence by providing skills-based training leading to a career in construction.
  - Support the construction of East Bank by helping trade partners get connected to talent and retain and grow their workforce.
  - Increase awareness of high wage career opportunities in the commercial construction industry.
  -
- WFD Pillars
  - K-12 Career Exploration
  - Partnership with PENCIL & If I Had a Hammer
  - Summer Teacher Externships
  -
- Career Training & Job Placement
  - Pre-Apprenticeship Training
  - NCCER Core Certification
    - Safety
    - Employability Skills
    - Communication Skills
    - Introduction to Power Tools
    - Introduction to Hands Tools
    - Introduction to Material Handling
    - Construction Drawings
    - Introduction to Construction Math
  - CPR training and medical attention classes
  - OSHA 10 Certification

- Participant paid weekly for training time. Funded through WIOA Funds for individuals that fall within a certain socioeconomic category; individuals that do not will be covered by project cost at \$18/hr.
- 
- TN Department of Labor Adult Education Program
  - Support learners with construction math and literacy
  - Translation assistance
  - Job shadow experience
  - Guaranteed job interview with trade partner(s) upon successful completion
- Wrap around support provided by American Job Center & Community Partners
  - Job Placement assistance
- Turner and Polk School of Construction Management (if Turner Construction or Polk & Associates is the General Contractor)
  - The objective of this program will be to increase visibility, improve economic viability, and expand opportunities for SMWBEs. Participants enrolled in the program will gain insight and access to meaningful tools to prepare their business for sustainable growth and develop new strategic professional relationships. We will structure the program to help build the capacity of SMWBE firms on the East Bank Redevelopment. The free eight-week program will be taught by Turner and Polk's local experts and uniquely devoted to a separate topic. Subjects covered during the program will include:
    - Safety
    - Accounting, insurance, and bonding
    - Project delivery systems and contract risk management
    - Bidding, estimating, and procurement
    - Scheduling and field operations
    - Marketing and business development

In addition, Fallon also will encourage reintegration of the vulnerable population. Fallon intends to work with groups like the Urban League of Middle Tennessee to provide expungement clinics for Davidson County residents. Fallon intends to work on building new relationships with other impactful groups in Nashville which could include the following:

- Project Return
- 4:13 Strong
- Men of Valor
- Urban League of Middle Tennessee

**Wage Theft:**

Fallon is proud to say wage theft is something that has never happened on a Fallon job site.

Fallon's construction manager's contracts shall hold the subcontractors to FLSA and Wage & Hour requirements. Violations to FLSA are punishable through fines and in extreme cases, could result in criminal prosecution. In addition, Fallon's construction manager shall also hold subcontractors to monthly certification that they have wage theft prevention procedures in place and certify that through all levels of their subcontracts.

Trade time records will be entered by front-line supervisors who have first-hand knowledge and supervision over hours worked.

Fallon shall require all subcontractors to uphold state and federal laws regarding paying any wages, and submit proper documentation on the monthly project pay application. Fallon shall require their construction manager(s), If there are violations of these laws, to require in their indemnification section of their contract with each subcontractor to withhold payment and/or issue joint checks directly to suppliers, vendors, and sub-subcontractors. Fallon shall require its construction manager(s) to require every subcontractor employee to attend an in-person site specific orientation on their first day on the project site. They will be issued a project specific sticker with a QR code that includes the employee's name, subcontractor employer, and date starting on project. This allows accurate records of each person working on the project to be kept.

In addition, Fallon shall implement a new policy requiring all subcontractors at each pay requisition (monthly) to certify that they verify to have paid all of their employees on a fair and equitable basis.

**Other Agreements:**

- Fallon agrees to make a good faith commitment to paying all construction employees an hourly wage equal to or better than the established living wage for Nashville as updated each year. See <https://www.nashvillelivingwage.com/> for wage information.
- All objectives and standards will apply to contractors, subcontractors, and sub-developers.
- Fallon shall require its construction manager(s) to use best efforts to track and report subcontractors' SMWBE business certification on a disaggregated basis, by category. Fallon shall collaborate with Metro's BAO to jointly set project specific goals for both small business and minority-owned business participation within the overall SMWBE project goal.
- Fallon shall report the latest data on a quarterly basis. Fallon shall ensure the construction manager provides data on each category of business. SMWBE participation efforts will be monitored, tracked, and reported throughout performance of contracts to identify and assess commitments and actual participation utilization progress for subcontractors and the overall goals.
  - Fallon shall collect and share information on vendors who are new to Metro projects participate in each project, so that Metro will have access to this information for analytical purposes.
- Fallon agrees to ensure the construction manager(s) timely share all reporting data relevant to this commitments on a public facing dashboard that can be housed on the project website.

**Exhibit A**

Legal Description of Campus Premises

Parcel Numbers

09302006800  
08215003000  
09303002200  
09302008700  
09303006600  
09303017400  
09303015300  
09307001000  
09303017100  
09303011500  
09307004600  
09307005100

Such parcels being lots 2, 3, 4, 5, 8, 9, 10, 11, and 12 on the Phase Two Subdivision Plat, Tennessee NFL Stadium, East Bank Redevelopment Plan, of record in Book 9700, Pages 986 and 987, R.O.D.C., and lots 13 and 14A on the Unified Plat of Subdivision of Lots 6, 13 & 14 of the Phase Two Subdivision Plat, Tennessee NFL Stadium, East Bank Redevelopment Plan, of record at Instrument No. 20100929-0077565, R.O.D.C., and lot 15 on the Resubdivision to Phase 2 Lot 15, Tennessee NFL Stadium, East Bank Redevelopment Plan, of record at Instrument No. 20100924-0076276, R.O.D.C., and further having been conveyed to Metro by deed of record at Instrument No. 20230901-0068581, R.O.D.C.



**Exhibit B-1**  
Depiction of IDA Land



**Exhibit B-2**  
Depiction of Premises



**Exhibit B-3**

Legal Description of the Premises  
[To be inserted upon survey completion]

**Exhibit B-4**  
Developer Pedestrian Bridge Component

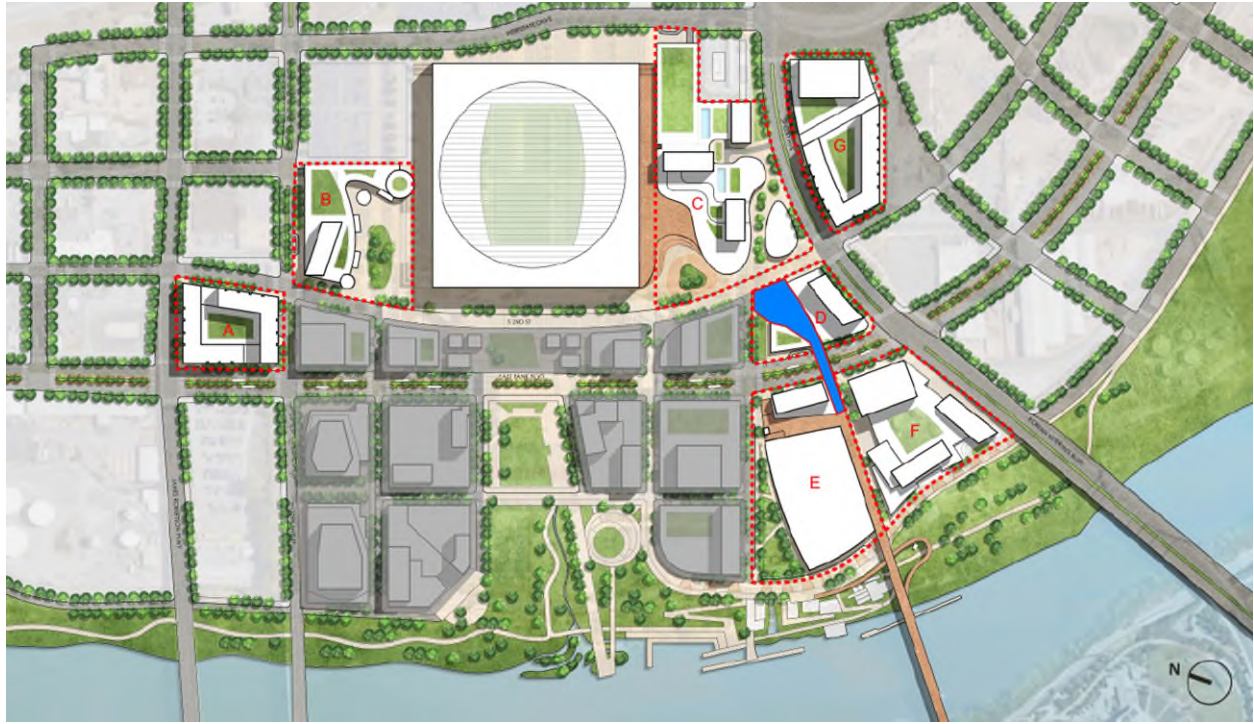

**Exhibit B-5**  
TPAC Pedestrian Bridge Extension Component



**Exhibit B-6**  
Second Street Plaza



**Exhibit B-7**  
TPAC Street Improvements

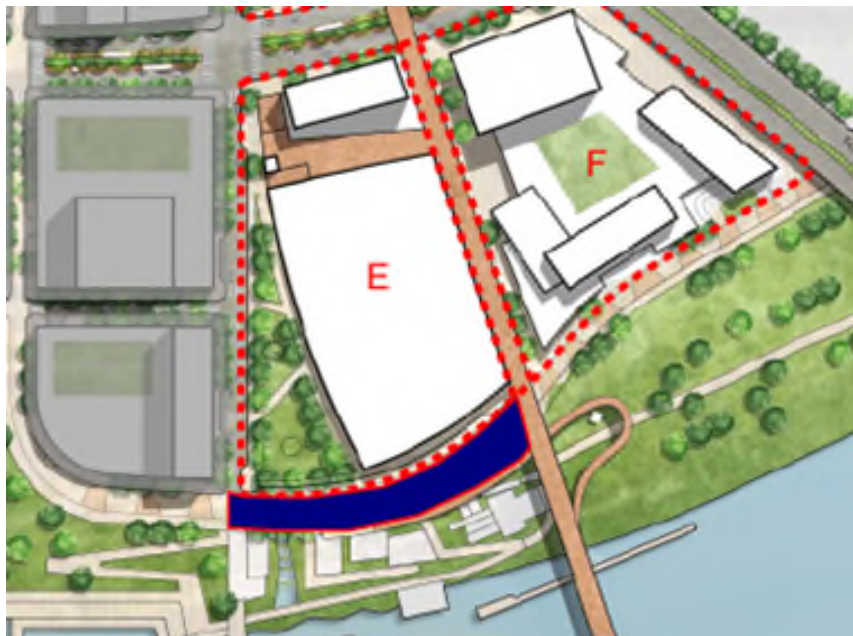
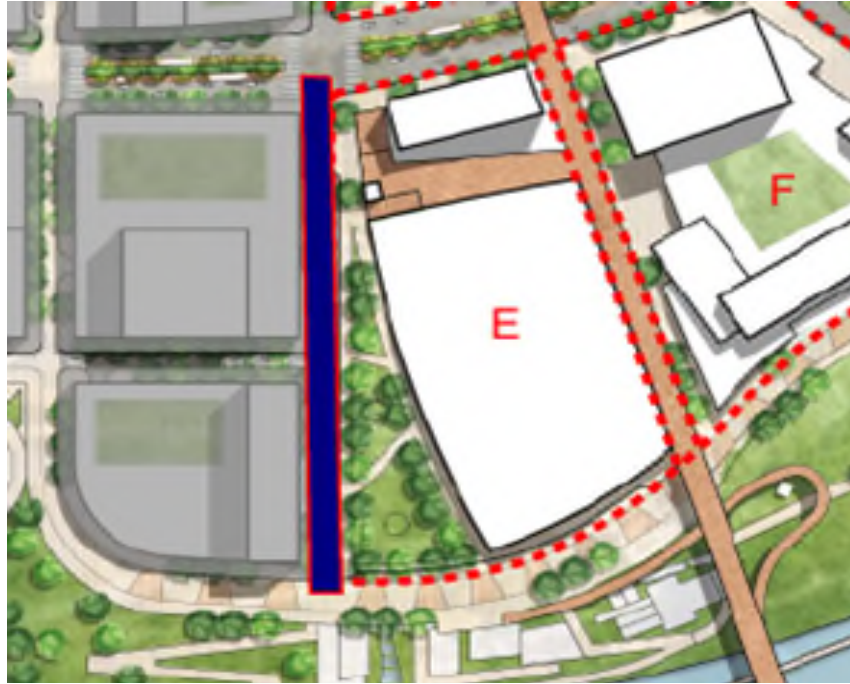

**Exhibit C-1**  
Form of Ground Lease



FORM OF GROUND LEASE

GROUND LEASE

Dated \_\_\_\_\_, 202\_\_

between

THE METROPOLITAN GOVERNMENT OF NASHVILLE AND DAVIDSON COUNTY,

as Landlord,

and

[\_\_\_\_\_],

as Tenant

For Premises Located at:

[\_\_\_\_\_]

**TABLE OF CONTENTS**

	<b>Page</b>
<b>ARTICLE 1 BASIC LEASE DATA; DEFINITIONS; EXHIBITS .....</b>	<b>1</b>
1.1 <b>Basic Lease Data .....</b>	1
1.2 <b>Additional Definitions .....</b>	3
1.3 <b>Exhibits and Schedules.....</b>	13
<b>ARTICLE 2 LEASE OF PREMISES; DELIVERY .....</b>	<b>14</b>
2.1 <b>Lease of Premises .....</b>	14
2.2 <b>Delivery of Premises .....</b>	14
2.3 <b>Declarations and other Permitted Encumbrances; Additional Easements .....</b>	14
2.4 <b>Reservation of Rights in Favor of Landlord .....</b>	16
2.5 <b>Memorandum of Lease.....</b>	16
<b>ARTICLE 3 TERM .....</b>	<b>16</b>
3.1 <b>Term.....</b>	17
3.2 <b>No Termination.....</b>	17
<b>ARTICLE 4 CONSTRUCTION OF IMPROVEMENTS.....</b>	<b>17</b>
4.1 <b>Improvements .....</b>	17
4.2 <b>Design and Construction Documents.....</b>	17
4.3 <b>Project Approvals .....</b>	18
4.4 <b>Initial Construction of Improvements .....</b>	19
4.5 <b>Mitigation Obligations.....</b>	21
4.6 <b>Soils Management and Tenant Environmental Work.....</b>	21
4.7 <b>Construction Insurance.....</b>	22
4.8 <b>Alterations .....</b>	22
<b>ARTICLE 5 RENT .....</b>	<b>24</b>
5.1 <b>Base Rent .....</b>	24
5.2 <b>Base Rent Adjustments .....</b>	24
5.3 <b>Additional Rent.....</b>	24
5.4 <b>Payment of Rent.....</b>	24
5.5 <b>Absolute Net Lease .....</b>	24
<b>ARTICLE 6 PAYMENT OF IMPOSITIONS.....</b>	<b>25</b>
6.1 <b>Payment of Impositions .....</b>	25
6.2 <b>Permitted Contests.....</b>	25
6.3 <b>Apportionment of Premises Not Separately Taxed .....</b>	25
6.4 <b>Receipt for Payment of Impositions .....</b>	25
6.5 <b>Special Provisions Regarding Property Taxes.....</b>	25
<b>ARTICLE 7 USE; COMPLIANCE WITH LEGAL REQUIREMENTS; MAINTENANCE             AND REPAIRS .....</b>	<b>26</b>
7.1 <b>Permitted Use .....</b>	26
7.2 <b>Prohibited Uses .....</b>	26
7.3 <b>No Adverse Possession.....</b>	26
7.4 <b>Compliance with Legal Requirements.....</b>	26
7.5 <b>Maintenance and Repairs.....</b>	26
7.6 <b>Waste; Nuisance.....</b>	27
7.7 <b>Repairs by Landlord.....</b>	27
<b>ARTICLE 8 UTILITIES.....</b>	<b>27</b>
8.1 <b>Tenant’s Responsibility For Utilities.....</b>	27

## TABLE OF CONTENTS

(continued)

	Page
<b>ARTICLE 9 INSURANCE AND INDEMNITY .....</b>	<b>27</b>
9.1 Insurance Requirements .....	27
9.2 Insurance Provisions .....	27
9.3 Waiver of Subrogation .....	28
9.4 Tenant's Indemnity .....	28
9.5 Tenant's Indemnity Unrelated to Insurance .....	29
9.6 Tenant's Assumption of Risk and Waiver .....	29
9.7 Landlord's Release .....	29
9.8 Survival .....	30
<b>ARTICLE 10 DAMAGE TO OR DESTRUCTION OF THE PREMISES.....</b>	<b>30</b>
10.1 Continuance of Lease .....	30
10.2 Damage or Destruction.....	30
10.3 Payment for Restoration. ....	31
10.4 Conditions to Payment. ....	32
10.5 Inconsistency with Financing Documents. ....	32
10.6 Destruction in the Last Twenty-Four Months. ....	32
<b>ARTICLE 11 CONDEMNATION .....</b>	<b>33</b>
11.1 Significant Taking.....	33
11.2 Restoration .....	34
11.3 Excess Cost .....	35
11.4 Taking of Fee.....	35
11.5 Temporary Taking.....	35
11.6 General Provisions.....	36
<b>ARTICLE 12 ASSIGNMENT AND TRANSFERS .....</b>	<b>36</b>
12.1 Assignment and Transfer Generally. ....	36
12.2 Definitions. ....	36
12.3 Transfers Allowed as of Right. ....	39
12.4 Transfers During Transfer Restriction Period.. ....	39
12.5 Transfers After Transfer Restriction Period. ....	39
12.6 Additional Requirements for Transfers. ....	39
12.7 Tenant's Liability. ....	40
12.8 Additional Encumbrances.....	40
12.9 Miscellaneous. ....	40
<b>ARTICLE 13 LEASEHOLD MORTGAGES .....</b>	<b>40</b>
13.1 Right to Mortgage and Obtain Mezzanine Financing.....	40
13.2 Leasehold Mortgage and Mezzanine Financing Security Not Requiring Landlord's Consent .....	40
13.3 Leasehold Mortgage and Mezzanine Financing Security Requiring Consent.....	41
13.4 General Limitations on Leasehold Mortgages and Mezzanine Financings.....	41
13.5 Permitted Leasehold Mortgagee and Permitted Mezzanine Lender .....	41
13.6 Rights of Permitted Leasehold Mortgagees and Permitted Mezzanine Lenders.....	42
<b>ARTICLE 14 SUBLETTING .....</b>	<b>44</b>
14.1 Right to Sublet .....	44
14.2 Attornment Provisions of Occupancy Sublease. ....	44
14.3 Occupancy Subtenants.....	45
14.5 Rights of Occupancy Subtenants.....	45

**TABLE OF CONTENTS**

(continued)

	<b>Page</b>
14.6 Termination of Subleases Other Than Occupancy Subleases .....	45
14.7 Delivery of Rent Rolls.....	45
<b>ARTICLE 15 FORCE MAJEURE.....</b>	<b>45</b>
15.1 Force Majeure.....	45
<b>ARTICLE 16 LIENS AND ENCUMBRANCES.....</b>	<b>46</b>
16.1 No Liens .....	46
16.2 Obligation to Obtain Release.....	46
16.3 NO SUBORDINATION .....	47
<b>ARTICLE 17 TITLE TO IMPROVEMENTS; SURRENDER OF PREMISES.....</b>	<b>47</b>
17.1 Title to Tenant Improvements and Tenant Equipment; Surrender; Holding Over.....	47
17.2 Re-Entry .....	49
17.3 Confirming Documents .....	50
17.4 Survival.....	50
<b>ARTICLE 18 DEFAULT; REMEDIES OF DEFAULT .....</b>	<b>50</b>
18.1 Event of Default Defined .....	50
18.2 Rights and Remedies of Landlord.....	51
18.3 Right of Re-entry .....	52
18.4 Late Fees and Default Interest.....	52
18.5 Landlord’s Right to Cure.....	52
<b>ARTICLE 19 REMEDIES CUMULATIVE .....</b>	<b>53</b>
19.1 Remedies Cumulative.....	53
19.2 Acceptance of payments.....	53
19.3 Restraining Orders .....	53
<b>ARTICLE 20 QUIET ENJOYMENT .....</b>	<b>53</b>
20.1 Landlord’s Covenant.....	53
<b>ARTICLE 21 ADDITIONAL COVENANTS AND REPRESENTATIONS .....</b>	<b>54</b>
21.1 Additional Covenants .....	54
21.2 Tenant Representations.....	54
21.3 Landlord Representations.....	55
<b>ARTICLE 22 LANDLORD TRANSFERS.....</b>	<b>56</b>
22.1 Landlord Transfers .....	56
22.2 East Bank Authority.....	56
22.3 Fee Mortgage.....	57
<b>ARTICLE 23 ENVIRONMENTAL MATTERS .....</b>	<b>57</b>
23.1 Hazardous Materials .....	57
23.2 Definitions.....	57
23.3 Indemnifications and Releases for Environmental Claims .....	58
23.4 Obligation to Remediate.....	58
23.5 Obligation to Notify .....	58
23.6 Right to Remediate .....	58
23.7 Acknowledgments of Tenant .....	59
23.8 General Provisions.....	59
<b>ARTICLE 24 RESERVED.....</b>	<b>59</b>

**TABLE OF CONTENTS**

(continued)

	<b>Page</b>
<b>ARTICLE 25 DISPUTE RESOLUTION .....</b>	<b>59</b>
25.1 <b>General .....</b>	59
25.2 <b>Resolution Proposal.....</b>	59
25.3 <b>Meet and Confer .....</b>	59
25.4 <b>Other Remedies.....</b>	60
<b>ARTICLE 26 NON-DISCRIMINATION AND AFFIRMATIVE ACTION.....</b>	<b>60</b>
26.1 <b>Compliance with Equal Opportunity Laws and Regulations.....</b>	60
26.2 <b>Information and Reports .....</b>	60
26.3 <b>Notices to Occupants, Contractors and Vendors.....</b>	60
<b>ARTICLE 27 NOTICES .....</b>	<b>60</b>
27.1 <b>Notices.....</b>	60
<b>ARTICLE 28 MISCELLANEOUS .....</b>	<b>62</b>
28.1 <b>Entire Agreement.....</b>	62
28.2 <b>Modifications.....</b>	62
28.3 <b>Captions and Section Numbers .....</b>	62
28.4 <b>Counterparts .....</b>	63
28.5 <b>Pronouns.....</b>	63
28.6 <b>Severability.....</b>	63
28.7 <b>Consents and Approvals.....</b>	63
28.8 <b>Satisfaction of Requirements .....</b>	63
28.9 <b>Waiver.....</b>	64
28.10 <b>Relationship of Parties .....</b>	64
28.11 <b>Binding Effect .....</b>	64
28.12 <b>Independent Covenants.....</b>	64
28.13 <b>Joint and Several Liability .....</b>	64
28.14 <b>Authority .....</b>	64
28.15 <b>Brokerage .....</b>	64
28.16 <b>Specific Performance of Landlord’s and Tenant’s Rights .....</b>	64
28.17 <b>No Recording.....</b>	65
28.18 <b>Depositaries .....</b>	65
28.19 <b>Development Agreement.....</b>	65
28.20 <b>Governing Law; Venue .....</b>	65
28.21 <b>Rule Against Perpetuities.....</b>	65
28.22 <b>No Merger .....</b>	65
28.23 <b>Exculpation.....</b>	65
28.24 <b>Estoppel Certificate .....</b>	66
28.25 <b>Confidentiality .....</b>	66

**GROUND LEASE**

THIS GROUND LEASE (this “**Lease**”) made as of this \_\_\_\_ day of [\_\_\_\_\_] (the “**Lease Commencement Date**”), by and between THE METROPOLITAN GOVERNMENT OF NASHVILLE AND DAVIDSON COUNTY, whose address is [\_\_\_\_\_] (“**Landlord**”), and [\_\_\_\_\_] (“**Tenant**”), whose address is [\_\_\_\_\_]. Each of Landlord and Tenant is sometimes referred to herein individually, as a “**Party**”, and Landlord and Tenant are sometimes referred to herein collectively, as the “**Parties**”.

In consideration of the mutual covenants and agreements contained herein, Landlord and Tenant hereby covenant and agree as follows:

**ARTICLE 1**

**BASIC LEASE DATA; DEFINITIONS; EXHIBITS**

Terms defined elsewhere in this Lease shall have the meanings ascribed to them. In addition, the terms defined below shall have the meanings ascribed to them wherever such terms shall appear in the Lease, unless the context requires otherwise.

1.1 **Basic Lease Data**. Each reference in this Lease to any of the following subject shall incorporate the data stated for that subject in this Section 1.1.

Landlord: As defined in the introductory paragraph above, together with its successors and permitted assigns.

Tenant: As defined in the introductory paragraph above, together with its successors and permitted assigns.

Premises: That certain parcel of land located in Nashville, Tennessee described in **Exhibit A-1** attached hereto (the “**Land**”) and shown as [\_\_\_\_\_] on that certain plan entitled “\_\_\_\_\_”, dated \_\_\_\_\_ and prepared by \_\_\_\_\_, a copy of which is attached hereto as **Exhibit A-2** (the “**Premises Plan**”), together with (i) the Tenant Improvements (as defined below), and (ii) the easements and rights benefitting the Land that are contained in the Declarations (as defined below) and specifically granted in this Lease to Tenant.

Campus: Certain real property in the East Bank area of the City of Nashville, comprising approximately 95 acres of land as described on **Exhibit B**.

Lease Commencement Date: As defined in the introductory paragraph above.

Lease Expiration Date: 11:59:59 p.m. on the last day of the initial Term.

Term: Ninety nine (99) years, beginning on the Lease Commencement Date and ending on the date that is ninety-nine (99) years thereafter.

Project: The Tenant Improvements that Tenant shall construct on the Premises, as described in the Approved Development Master Plan (as defined

below) and the Final Plans and Specifications (as defined below), subject to the terms and provisions of this Lease.

Approved Development

Master Plan:

That certain development master plan for the development and construction of the Project attached hereto as **Exhibit D-1**, as the same may be modified from time to time subject to the provisions of this Lease. **[NTD: ATTACH THE APPROVED DEVELOPMENT MASTER PLAN UNDER THE DEVELOPMENT AGREEMENT]**

Final Plans and Specifications:

Those certain plans and specifications for the design of the Project listed on **Exhibit E-1** attached hereto, as the same may be modified from time to time subject to the provisions of this Lease. **[NTD: INCLUDE THE LIST OF PLANS AND SPECIFICATIONS PREPARED IN ACCORDANCE WITH THE DEVELOPMENT AGREEMENT]**

Development Agreement:

That certain Master Development Agreement by and between The Metropolitan Government of Nashville and Davidson County, (“**Owner**”) and TFC Nashville LLC, a Delaware limited liability company (together with its successors and assigns, “**Developer**”), and joined by The Fallon Company LLC, a Massachusetts limited liability company, dated as of [\_\_\_\_], 2024 together with the exhibits and schedules thereto, as the same has been amended to date and as the same may hereafter be amended or modified from time to time. Wherever this Lease contains a cross-reference to the Development Agreement (including but not limited to any provision of this Lease entitling Landlord or Tenant to exercise a right hereunder, or requiring Landlord or Tenant to perform an obligation hereunder, “as provided in” or “in accordance with” the Development Agreement, or words to similar effect), Landlord or Tenant, as applicable, shall be entitled to exercise its rights hereunder or enforce the other Party’s obligations hereunder, as applicable, in reliance upon and with reference to the applicable provision(s) of the Development Agreement to the same extent as if Landlord and Tenant were the “Owner” and the “Developer” thereunder, respectively. All references herein to the Development Agreement shall include all exhibits and schedules thereto.

Permitted Uses:

All uses permitted on the Land under the Project Approvals (as defined below), in each case, other than Prohibited Uses (as defined below).

Base Rent:

The annual Base Rent for the first Lease Year shall be equal to \$[\_\_\_\_\_], (plus if the first Lease Year includes a partial month, a pro rata amount for such partial month, at such annual rate). Base Rent is payable in equal monthly installments in advance on the first day of each calendar month commencing on the Rent Commencement Date, as set forth in Section 5.1 and subject to adjustment as set forth in Section 5.2

Scope of Work Document: That certain scope of work document attached hereto as Exhibit D-2. [All references herein to the Scope of Work Document shall include the Environmental MOU (as defined below) and all other attachments.]

1.2 **Additional Definitions.** In addition to the terms set forth above, the following terms shall be defined as indicated.

“**Acquisition Financing**” shall mean (i) the loan evidenced by the first Leasehold Mortgage and if applicable, the loan evidenced by the first Mezzanine Financing on the Premises, and (ii) any subsequent debt financing which serves as the source of capital for a purchase of the Tenant’s interest in the Premises in a Sale Transaction, including any amounts used for costs attributable to such acquisition as well as improvements to the Premises by the new Tenant.

“**Additional Rent**” shall have the meaning set forth in Section 5.3.

“**Affiliate**” shall mean with respect to any person or entity, any other person or entity that, directly or indirectly (through one or more intermediaries), Controls, is Controlled by, or is under common Control with, such first person or entity.

“**Alterations**” shall have the meaning set forth in Section 4.8 herein.

“**Anticipated Project Schedule**” shall mean the anticipated development schedule for Tenant’s development and construction of the Project attached hereto as **Exhibit G**, as of the Effective Date, as the same may be modified from time to time subject to the provisions of this Lease. [NTD: TO INCLUDE DEVELOPMENT SCHEDULE (OR THE APPLICABLE PORTION THEREOF) PREPARED BY DEVELOPER IN ACCORDANCE WITH THE DEVELOPMENT AGREEMENT.]

“**Applicable Declaration**” shall mean either the Pedestrian Bridge Declaration or the Second Street Plaza Declaration as and to the extent that either such Declaration actually encumbers the Premises.

“**Appropriate Metro Staff**” means the Metropolitan Mayor or such employees of the Metropolitan Government with expertise in the applicable approval matter as he or she may reasonably designate from time to time.

“**Approvals**” shall mean collectively, all environmental, land use, building, construction, occupancy and related permits, and any other permits, licenses and approvals required by applicable federal, state or local statutes, laws, rules, regulations, codes, ordinances, directives, orders or decrees (whether now existing or hereafter enacted, promulgated or issued), as the same may be amended from time to time, which are necessary to enable Tenant to construct and use the Tenant Improvements or any portion thereof, including, without limitation, zoning and project review approvals and any agreements related thereto or required in connection therewith; permits required for off-site mitigation; permits relating to sewer, water or drain connections, parking and traffic management; and Federal Aviation Authority determinations, if applicable.

“**Approved Development Master Plan**” shall have the meaning set forth in Section 1.1.

“**Approved Plans**” shall have the meaning set forth in Section 4.2(a).

“**Approved Project Budget**” shall mean the development budget for the development and construction of the Project attached hereto as **Exhibit F**, as the same may be modified from time to time by



Developer. [NTD: TO INCLUDE DEVELOPMENT BUDGET (OR THE APPLICABLE PORTION THEREOF) PREPARED BY DEVELOPER IN ACCORDANCE WITH THE DEVELOPMENT AGREEMENT.]

“**Approved Project Documents**” shall mean, collectively, the Scope of Work Document, the Approved Project Budget, the Anticipated Project Schedule and the Construction Management Plan, in each case as may be modified in accordance with the terms of this Lease.

“**Architect**” shall have the meaning set forth in Section 4.4(d).

“**Base Rent**” has the meaning forth in Article 1.

“**Base Rent Adjustment**” has the meaning set forth in Section 5.2.

“**Base Rent Escalator**” shall mean the applicable percentage as follows: (a) for each of the first ten (10) Lease Years, 2.5%, and (b) at the commencement of Lease Year eleven (11), and at the commencement of each tenth Lease Year thereafter, the applicable percentage for each succeeding ten (10)-Lease Year period will be the greater of (x) 2.5% or (y) one-tenth of the percentage increase in the CPI over the preceding ten (10)-Lease Year period, but in no event more than 2.75% (i.e., the annual Base Rent Escalator will start at 2.5% per year for the first ten Lease Years and reset at the start of each ten (10)-Lease Year period thereafter, and will always be in the range of 2.5% and 2.75%).

“**Borrower**” means the borrower under a Refinancing Transaction.

“**Building(s)**” shall mean singly each of, and collectively, as the context requires, the building or buildings to be constructed on the Premises pursuant to the Approved Development Master Plan and the Final Plans and Specifications for such building(s).

“**Business Day**” shall mean each day of the week, Monday through Friday, excluding holidays that are officially observed in the State of Tennessee or Commonwealth of Massachusetts.

“**Campus**” has the meaning forth in Article 1.

“**Campus Operations Agreement**” means that certain Campus Operations and Use Agreement between Landlord, Developer, and Tennessee Stadium, LLC dated as of \_\_\_\_\_, 2024.

“**Casino**” means any building that provides gambling-based games typically found in casinos that consist of dealing, operating, carrying on, conducting, maintaining, or exposing for play any game played with cards, dice, equipment, or any mechanical or electromechanical device, such as poker, roulette, craps, twenty-one, black jack, baccarat, slot machines, keno or any other gambling-based game similar in form or content where money or credit is wagered.

“**Certificate of Occupancy**” shall have the meaning set forth in Section 4.4(a)(ii).

“**Code**” shall mean the Internal Revenue Code of 1986, as amended from time to time, or any successor statute.

“**Construction Management Plan**” shall mean that certain construction management plan attached hereto as **Exhibit H**, as the same may be modified from time to time subject to the provisions of this Lease.

**“Control”** shall mean the power to direct the management or policies of an entity or conduct the day-to-day business operations of such entity (directly or indirectly), whether through the ownership of voting securities, partnership or other ownership interests, by contract or otherwise (including being the general partner, officer or director of the entity in question); provided, however, that Control shall not be deemed absent solely because a non-managing member, partner or shareholder has the right to approve certain customary major decisions.

**“CPI”** shall mean and refer to the Consumer Price Index for All Urban Consumers (CPI-U), All Items, South (Index 1982-1984=100, not seasonally adjusted), as published by the Bureau of Labor Statistics, United States Department of Labor. If at any time during the Term of this Lease, the United States Bureau of Labor Statistics discontinues the issuance of such Index, or such Index shall be superseded as the generally accepted cost of living index, the “CPI” shall mean the successor cost of living index or any other standard nationally recognized cost of living index agreed upon by Landlord and Tenant. If any monthly CPI is not available for use, the CPI as issued and published for the earliest preceding month shall be used. If the CPI ceases to be published on a monthly basis, then the shortest stated period for which it is published shall be used for purposes of this Lease.

**“Date of Taking”** shall have the meaning set forth in Section 11.1(c).

**“Default Rate”** shall mean the maximum non-usurious rate of interest, if any, that may be contracted for, taken, reserved, charged or received under applicable Legal Requirements.

**“Depository”** shall mean the Leasehold Mortgagee, if at the subject time there is a Leasehold Mortgage on the Premises, and otherwise, any bank or trust company chartered under the laws of the United States of America or the State of Tennessee with a combined capital and surplus account of not less than \$50,000,000.00, (which amount shall be adjusted annually on each anniversary of the Lease Commencement Date to reflect any increases in CPI during the period from the Lease Commencement Date through the applicable date upon which the adjustment shall take place), selected by the mutual agreement of Landlord and Tenant, which, in accordance with such terms as the parties may agree, shall agree to act as depository of funds for purposes provided in this Lease.

**“Developer”** shall have the meaning set forth in Section 1.1.

**“Development Agreement”** shall have the meaning set forth in Section 1.1.

**“Dispute”** shall have the meaning set forth in Section 25.1.

**“Dispute Notice”** shall have the meaning set forth in Section 25.1.

**“Dispute Resolution Proposal”** shall have the meaning set forth in Section 25.2.

**“East Bank Authority”** shall mean an authority or instrumentality formed with the reasonable input of Developer for the purposes of owning and/or administering the IDA Land.

**“East Bank Authority Transfer”** shall have the meaning set forth in Section 22.2.

**“Eligibility Requirements”** shall mean with respect to any Person, that such Person (a) has total assets (in name or under management or advisement) in excess of \$500,000,000 (which amount shall be adjusted on each anniversary of the Lease Commencement Date to reflect any increases in CPI during the period from the Lease Commencement Date through the date on which the adjustment shall take place) and (b) is regularly engaged in the business of making or owning (or, in the case of a pension advisory firm or

similar fiduciary, regularly engaged in managing investments in) commercial real estate loans (including mezzanine loans to direct or indirect owners of commercial properties, which loans are secured by pledges of direct or indirect ownership interests in the owners of such commercial properties) or operating commercial properties.

**“Environmental Due Diligence Information”** shall mean any and all information and data developed in connection with any environmental studies, investigations, reports, testing or remediation conducted or prepared by or for Developer or Tenant as permitted under the Development Agreement or this Lease or provided by Landlord or Owner to Developer or Tenant.

**“Environmental MOU” shall have the meaning assigned to such term in the Scope of Work Document. [NTD: To be deleted if no premium costs at subject Ground Lease Premises]**

**“Environmental Report”** shall mean collectively, (i) the Phase I Environmental Site Assessment Report dated March 17, 2021, prepared by Professional Service Industries, Inc. for Tennessee Football, Inc. (PSI Project Number 03581624-1), (ii) the Report of Phase II Environmental Site Assessment prepared by Geo-Technology Associates, Inc for Tennessee Football, Inc. (GTA Project Number 31230396), and (iii) any environmental assessments prepared with respect to the Premises on behalf of Tenant.

**“Environmental Requirements”** shall have the meaning set forth in Section 23.2(a).

**“Equity Pledge”** shall mean the granting of a pledge of the direct or indirect interests in Tenant as collateral for any indebtedness secured by a Leasehold Mortgage or for any Mezzanine Financing, in each case to the extent permitted by this Lease.

**“Event(s) of Default”** shall have the meaning set forth in Section 18.1.

**“Excess Refinancing Proceeds”** means the Refinancing Proceeds less the amounts, if any, required to (i) pay in full the loan(s) being refinanced by the Refinancing Transaction and (ii) achieve a Return of Owners’ Capital. For the avoidance of doubt, for a typical loan extension or similar transaction where the principal amount of the loan is not increased or where no loan proceeds are distributed, there will be no Excess Refinancing Proceeds.

**“Excluded Claim”** shall mean any Liability that arises from (x) the fraud, gross negligence, bad faith or willful misconduct of a Party seeking indemnification hereunder (or any of its Affiliates, agents, officers or employees), or (y) the intentional breach by such Party (or any of its Affiliates) of this Lease or the Development Agreement.

**“Exempt Sale Transactions”** means (i) Transfer of eighty percent (80%) or less of the direct or indirect beneficial interests in Tenant in the aggregate (whether in a single transaction or in a series of related transactions) that does not result in a change in Control of Tenant, (ii) any Transfers Allowed as of Right (other a Transfer of eighty (80%) or more of the direct or indirect beneficial interests in Tenant, whether in a single transaction or in a series of related transactions (except for a Foreclosure Sale)), and (iii) the sale or grant of any other security interest Tenant’s leasehold interest or in equipment, inventory, fixtures, and other personal property at the Premises in connection with a financing or refinancing of the same permitted under this Lease.

**“Fee Mortgage”** shall have the meaning set forth in Section 22.3.

**“Final Completion”** shall have the meaning set forth in Section 4.4(a)(iii).

“**Final Plans and Specifications**” shall have the meaning set forth in Section 1.1.

“**First Dispute Resolution Period**” shall have the meaning set forth in Section 25.2.

“**Force Majeure Event**” shall have the meaning set forth in Section 15.1.

“**Foreclosure Sale**” shall have the meaning set forth in Section 12.2(a)(6).

“**Future Environmental Conditions**” shall have the meaning set forth in Section 23.2(f).

“**Future Migration Conditions**” shall have the meaning set forth in Section 23.2(g).

“**Future Participation Rent**” shall have the meaning set forth in Section 5.5(a).

“**Future Project Approvals**” shall have the meaning set forth in Section 4.3(a).

“**Future Project Approvals Filings**” shall have the meaning set forth in Section 4.3(b).

“**Future Tenant Environmental Work**” shall have the meaning set forth Section 4.6(a).

“**General Contractor**” shall have the meaning set forth in Section 4.4(d).

“**Governmental Authority (Authorities)**” shall mean any governmental authority, agency, board or other public party having jurisdiction over the Premises (or any portion thereof), the development of the Project, or the granting of any of the Approvals, and any subcommittee or other subgroup or any member or members thereof.

“**Ground Leases**” shall have the meaning set forth in the Development Agreement.

“**Guarantor**” shall mean [\_\_\_\_\_]. **[NTD: Guarantor to be a Guarantor as defined in the Development Agreement]**

“**Guaranty**” shall mean that certain Guaranty of Completion of even date herewith executed by Guarantor in favor of Landlord with respect to certain of Tenant’s obligations under this Lease as more particularly set forth therein.

“**Hazardous Materials**” shall mean collectively, all substances defined or classified as a “hazardous substance”, “hazardous material”, “hazardous waste”, “pollutant”, or otherwise denominated as a regulated or hazardous substance, waste or material, toxic or pollutant in any of the following: (i) the federal Comprehensive Environmental Response, Compensation and Liability Act of 1980; (ii) the federal Hazardous Materials Transportation Uniform Safety Act of 1990; (iii) the federal Toxic Substances Control Act; (iv) the federal Resource Conservation and Recovery Act; (v) the Tennessee Air Quality Act, T.C.A. 68-201-101 *et seq.*; (vi) the Tennessee Hazardous Waste Management Act, T.C.A. 68-212-101 *et seq.*; (vii) the Tennessee Petroleum Underground Storage Tank Act, T.C.A. 68-215-101 *et seq.*; (viii) the Tennessee Water Quality Control Act of 1977, T.C.A. 69-3-101 *et seq.*; (ix) any other federal, state or local law addressing itself to environmental contamination, waste or health and safety; and (x) any regulations promulgated under any of the foregoing, including, without limitation, regulations promulgated by TDEC; as any of the foregoing may be promulgated or amended from time to time. “Hazardous Materials” shall specifically include, but not be limited to, oil, asbestos, explosives, polychlorinated biphenyls, petroleum and petroleum based derivatives, and urea formaldehyde.

**“Impositions”** shall mean (a) real property taxes and assessments (including without limitation, all assessments for public improvements or benefits, whether or not commenced or completed prior to the Lease Commencement Date and whether or not to be completed within the Term) and all payments in lieu of such taxes; (b) personal property taxes and all payments in lieu of such taxes; (c) occupancy and rent taxes; (d) water, water meter and sewer rents, rates and charges; (e) vault charges; (f) levies; (g) license and permit fees; (h) service charges, with respect to police protection, fire protection, street and highway maintenance, construction and lighting, sanitation and water supply, if any; (i) excise or similar taxes imposed or levied upon, assessed against or measured by Rent payable hereunder, (j) all excise, sales, value added, use and similar taxes; (k) payments in lieu of each of the foregoing expressly so designated; (l) fines, penalties and other similar or like governmental charges applicable to any of the foregoing and any interest or costs with respect thereto; and (m) any and all other federal, state, county and municipal governmental and quasi-governmental levies, fees, rents, assessments or taxes and charges, general and special, ordinary and extraordinary, foreseen and unforeseen, of every kind and nature whatsoever, and any interest or costs with respect thereto, in each case solely to the extent attributable to the Premises.

**“Initial Tenant Environmental Work”** shall have the meaning set forth Section 4.6(a).

**“Institutional Lender(s)”** shall mean (i) any real estate investment trust, bank, saving and loan association, investment bank, insurance company, trust company, commercial credit corporation, pension plan, pension fund or pension advisory firm, mutual fund, government entity or plan, *provided* that any such Person referred to in this *clause (i)* satisfies the Eligibility Requirements; (ii) an investment company, money management firm or “qualified institutional buyer” within the meaning of Rule 144A under the Securities Act, or an institutional “accredited investor” within the meaning of Regulation D under the Securities Act, *provided* that any such Person referred to in this *clause (ii)* satisfies the Eligibility Requirements; (iii) a governmental authority or quasi-governmental agency empowered to make loans or issue bonds; (iv) an institution substantially similar to any of the entities described in *clause (i)*, *(ii)* above or *clause (vi)* below that satisfies the Eligibility Requirements; (v) any entity Controlled by, Controlling or under common Control with any of the entities described in *clause (i)*, *(ii)* or *(iii)* above or *clause (vi)* below; or (vi) an investment fund, limited liability company, limited partnership or general partnership where a Permitted Fund Manager acts as general partner, managing member or fund manager and at least fifty percent (50%) of the equity interests in such investment vehicle are owned, directly or indirectly, by one (1) or more of the following: an Institutional Lender, an institutional “accredited investor”, within the meaning of Regulation D promulgated under the Securities Act, or a “qualified institutional buyer” or both within the meaning of Rule 144A promulgated under the Exchange Act, *provided* such institutional “accredited investors” or “qualified institutional buyers” that are used to satisfy the fifty percent (50%) test set forth above in this *clause (v)* satisfy the financial tests in *clause (a)* of the definition of Eligibility Requirements; provided that in any case such Person is not a Prohibited Person, and in each case irrespective of whether any such entity is acting individually or in a fiduciary or representative (such as an agency) capacity.

**“Known Existing Conditions”** shall have the meaning set forth in Section 23.2(c).

**“Land”** shall have the meaning set forth in Section 1.1.

**“Landlord”** shall have the meaning set forth in the Preamble.

**“Landlord Environmental Obligations”** shall be mean Landlord’s reimbursement obligations set forth in Section 4.6(c).

**“Landlord Interested Party”** shall have the meaning set forth in Section 28.24.

**“Landlord Party/Parties”** shall mean Landlord and any Affiliate of Landlord and any other party as may now or hereafter be owned by Landlord, as may be identified by written notice from Landlord to Tenant from time to time, and any and all of their respective officers, trustees, directors, shareholders, partners, members, managers, equity owners, members of governing boards, employees, contractors, agents, representatives or Persons acting on behalf of any of them.

**“Landlord Transfer”** shall have the meaning set forth in Section 22.1.

**“Landlord’s Confidential Information”** shall have the meaning set forth in Section 28.25(a).

**“Landscape Architect”** shall have the meaning set forth in Section 4.4(d).

**“Lease”** shall have the meaning set forth in the Preamble.

**“Lease Commencement Date”** shall have the meaning set forth in the Preamble.

**“Lease Expiration Date”** shall have the meaning set forth in Section 1.1.

**“Lease Year”** shall mean each period of twelve calendar months during the Term, beginning on the Rent Commencement Date, provided, however, that if the Rent Commencement Date does not occur on the first day of a calendar month, the first Lease Year shall include the partial month in which the Rent Commencement Date occurs, and will end on the anniversary of the first day of the month immediately following the Rent Commencement Date, and further provided that the last Lease Year shall end on the Lease Expiration Date.

**“Leasehold Mortgage”** shall mean any mortgage on Tenant’s leasehold estate in the Premises under this Lease pursuant to Article 13.

**“Leasehold Mortgagee”** shall mean the holder of a Leasehold Mortgage.

**“Legal Requirements”** shall mean (1) all applicable present and future statutes, regulations, rules, ordinances, codes, common law, licenses, permits, orders, approvals, plans, authorizations, concessions, franchises, and similar items, and all amendments thereto, of all Governmental Authorities, and all applicable judicial, administrative and regulatory decrees, judgments, and orders relating to, including the Americans With Disabilities Act, 42 U.S.C. §12101 et seq., the regulations and guidelines issued pursuant thereto, and any law of like import, and all rules, regulations and government orders with respect thereto, and (2) all Environmental Requirements.

**“Liability(s)”** shall have the meaning set forth in Section 9.5.

**“Material Alteration”** shall mean any Alteration that (i) does not comply with applicable zoning laws or building regulations then existing or prevailing or the Approved Master Plan (as the same may have been modified or otherwise supplemented in accordance with this Agreement), (ii) would result in a change in use that is inconsistent with the Approved Master Plan, (iii) would materially and adversely affect access to or use of the Second Street Plaza or the Pedestrian Bridge (as those terms are defined in the Second Street Plaza Declaration and Pedestrian Bridge Declaration, respectively), (iv) would materially and adversely affect the character of the public or quasi-public areas on the Premises, or (v) would materially and adversely affect pedestrian access between the Premises and other areas of the Campus.

**“Mezzanine Financing”** shall mean one or more loans made to Tenant or to any person or entity that owns (directly or indirectly) an ownership interest in Tenant, in each case, in connection with Tenant’s

leasehold interest under this Lease, which is secured by a security interest in or pledge in Tenant or in any entity which owns (directly or indirectly) an ownership interest in Tenant, and such other security given to the Mezzanine Lender as is customary for mezzanine loans and related to the foregoing collateral (such as guaranties, letters of credit, or financial instruments) (“**Mezzanine Financing Security**”). Any and all Mezzanine Financing shall (a) not be cross-collateralized with any other loan, (b) have a maturity date not later than the end of the Term, and (c) be made by an Institutional Lender.

“**Mezzanine Financing Security**” shall have the meaning set forth above in the definition of Mezzanine Financing.

“**Mezzanine Lender**” shall mean an Institutional Lender under any Mezzanine Financing.

“**Nonrecourse Party**” shall have the meaning set forth in Section 28.23.

“**Obsolescence Notice**” shall have the meaning set forth in Section 17.1(e).

“**Obtained Project Approvals**” shall have the meaning set forth in Section 4.3(a).

“**Occupancy Sublease**” shall have the meaning set forth in Section 14.3.

“**Occupancy Subtenant**” shall have the meaning set forth in Section 14.3.

“**Other Institutional Projects**” shall have the meaning assigned to such term in the Development Agreement.

“**Owner**” shall have the meaning set forth in Section 1.1.

“**Owner-Caused Delays**” shall have the meaning set forth in the Development Agreement.

“**Owner Mitigation Obligations**” shall have the meaning set forth in the Development Agreement.

“**Parties**” shall have the meaning set forth in the Preamble.

“**Party**” shall have the meaning set forth in the Preamble.

[“**Pedestrian Bridge Declaration**” shall mean that certain [\_\_\_\_\_] dated [\_\_\_\_\_, 20\_\_], [to be] recorded [as Instrument \_\_\_\_] with the Registry, as the same may be amended, modified or supplemented from time to time].

“**Permitted Closures**” means (i) any period during which Tenant (or any Subtenant) is unable to open for business or operate due to a Force Majeure Event (so long as Tenant is actively pursuing the collection of applicable proceeds and, subject to any further Force Majeure Event, restoration following any such event), (ii) temporary closures of portions of the Premises periodically for Restoration, or in order to remodel or refurbish or make Alterations to the same so long as Tenant accomplishes such remodeling or refurbishment or Alterations with commercially reasonable diligence and endeavors to keep the remainder of the Premises open as much as reasonably practical during that period, or (iii) any vacancy or closure resulting from the termination or cessation of operations of occupants under Subleases so long as Tenant is actively marketing the affected area for sublease.

**“Permitted Encumbrances”** shall mean all Permitted Encumbrances (as such term is defined in the Development Agreement) applicable to the Land as of the Lease Commencement Date, as the same may be amended, modified, restated, supplemented or eliminated from time to time with the prior written consent of Tenant. [NTD: This Lease is subject to revision to (i) accurately capture all applicable CC&Rs, REAs, and other similar documents of record and encumbering the Premises, entered into and recorded in accordance with the Development Agreement (e.g., to the extent of record and encumbering the Premises, the Campus Operations and Use Agreement, Parking Development Agreement, Site Coordination Agreement, Etc.), and (ii) clarify the allocation of respective rights and/or obligations under such documents]

**“Permitted Fund Manager”** shall mean any Person that on the date of determination is (i) any nationally-recognized manager of investment funds investing in debt or equity interests relating to commercial real estate, (ii) investing through a fund with committed capital of at least \$250,000,000 (as adjusted on each anniversary of the Lease Commencement Date for any increases in CPI during the prior year), and (iii) not subject to a proceeding or other action under any existing or future law of any jurisdiction relating to bankruptcy, insolvency, reorganization or relief of debtors.

**“Permitted Leasehold Mortgagee”** shall have the meaning set forth in Section 13.5.

**“Permitted Mezzanine Lender”** shall have the meaning set forth in Section 13.5.

**“Permitted Uses”** shall have the meaning set forth in Section 1.1.

**“Person”** (or the term **“person”**) shall mean a natural person or a corporation, partnership, limited liability company, unincorporated organization or government, or any agency or political subdivision thereof and any other entity, whether or not incorporated, and the heirs, executors, administrators, legal representatives, successors and assigns of such Person where the context so admits.

**“Pre-Existing Environmental Conditions”** shall have the meaning set forth in Section 23.2(d).

**“Premises”** shall have the meaning set forth in Section 1.1.

**“Premises Plan”** shall have the meaning set forth in Section 1.1.

**“Prime Rate”** shall mean the rate announced (whether or not actually charged) from time to time by Citibank, N.A., or any successor of such bank, as its base/reference rate (or the equivalent) in effect in New York City, or, if no such bank shall exist, the rate published by The Wall Street Journal (or, if The Wall Street Journal shall no longer regularly publish such rate, a domestic financial newspaper of comparable status) from time to time as the generally prevailing rate of interest charged by commercial banks on ninety (90) day unsecured loans (or if no such rate is available a replacement rate reasonably designated by Landlord).

**“Prohibited Person”** shall have the meaning set forth in Section 12.2(c).

**“Prohibited Uses”** shall mean the following uses: (1) any discotheque (except as an ancillary use); (2) beauty school or barber college; (3) any gasoline or service station, automotive service or repair business; (4) any dry cleaner that has on-site dry cleaning; (5) any “second hand” store, used clothing or thrift store, pawn shop, salvation army type store, “surplus” store or liquidation outlet; (6) any mortuary or funeral parlor not part of a medical institutional use; (7) any coin operated laundry, except as an ancillary use in a residential, hotel, assisted living or similar facility; (8) the sale, display, cultivation, development, distribution, and/or administration of narcotics or any other controlled substances not part of a doctor’s



office or laboratory, or full-service pharmacy, including any adult-use cannabis establishment, cannabis retailer, cannabis manufacturer, cannabis cultivator, or methadone clinic; (9) any massage parlor not accessory to a fitness center, residential or office building, spa or hotel; (10) “head” shop, adult book shop or adult movie house, or piercing parlor; (11) sports betting and Casinos, provided, however the foregoing shall not prohibit gambling or games of chance unrelated to real world sports competition operated by the Tennessee Lottery or an event benefitting a non-profit organization that is permitted by other Governmental Authorities or legal online gambling by Persons using their own devices; (12) short term rentals (such as, by way of example only, Air BnB and VRBO) of any non-hotel multifamily or other residential property; and (13) any other use to the extent prohibited by the Campus Operations Agreement or by the Applicable Declaration.

“**Project**” shall have the meaning set forth in Section 1.1.

“**Project Approvals**” shall mean the Obtained Project Approvals and Future Project Approvals.

“**Refinancing Proceeds**” shall mean the gross proceeds received by Borrower in a Refinancing Transaction less (i) the portion of such proceeds used or to be used for the construction, repair, replacement, refurbishment, expansion, leasing, marketing or maintenance of the Tenant Improvements or used or to be used for similar purposes related to the Tenant Improvements or the Premises, (ii) the portion of such proceeds escrowed or reserved or, without duplication, otherwise not available for the use of Borrower, (iii) the portion of such proceeds used for working capital, interest on such financing by Borrower, and (iv) Transaction Costs.

“**Refinancing Transaction**” shall mean any of the following transactions, but in all cases excluding Acquisition Financing:

- (a) Any indebtedness incurred by Tenant that is secured by a Leasehold Mortgage on all or any portion of Tenant’s interest in the Premises;
- (b) Any Mezzanine Financing incurred by Tenant or any person or entity that owns (directly or indirectly) an ownership interest in Tenant;
- (c) The issuance by Tenant or any borrower under Mezzanine Financing of any indebtedness, the proceeds of which are used to repay existing indebtedness;
- (d) Any amendment or modification (other than an amendment or modification entered into solely to correct a manifest or clerical error), novation, extension, renewal, supplement, defeasance, or replacement of any of the foregoing transactions, the effect of which is to provide additional loan proceeds to Borrower;
- (e) Any other arrangement put in place by Tenant or any person or entity that owns (directly or indirectly) an ownership interest in Tenant that has a purpose and effect that is similar to any of items (a) through (d) above.

“**Registry**” shall mean the Office of the Register of Deeds for Davidson County, Tennessee.

“**Release**” shall have the meaning set forth in Section 23.2(b).

“**Removal Notice**” shall have the meaning set forth in Section 17.1(e).

“**Rent**” shall mean, collectively, Base Rent and Additional Rent.

**“Rent Commencement Date”** shall mean the first day of the month following the date on which Tenant achieves Substantial Completion of the Tenant Improvements; provided, however, that if Tenant has entered into construction financing for the Project with a Permitted Leasehold Mortgagee or Permitted Mezzanine Lender, then the Rent Commencement Date shall be the date that is ninety (90) days following the outside date for Tenant to achieve substantial completion of the Tenant Improvements, as set forth in the loan documents for the Tenant’s construction financing and as disclosed to Landlord promptly following the closing of such construction financing.

**“Rent Roll”** shall mean a rent roll for the Tenant Improvements on the Premises, which shall be a true and correct copy of the rent roll maintained by the Tenant in its ownership and/or operation of the Project.

**“Repairs”** shall have the meaning set forth in Section 7.5.

**“Representatives”** shall mean, with respect to any Person, such Person’s employees, officers, directors, principals, agents, consultants and contractors.

**“Restore”** shall have the meaning set forth in Section 10.2.

**“Restoration”** shall have the meaning set forth in Section 10.2.

**“Restoration Funds”** shall have the meaning set forth in Section 10.3.

**“Restricted Party”** means Tenant and any shareholder, partner, member or non-member manager, or other direct or indirect legal or beneficial owner of Tenant that has the right, directly or indirectly, to Control Tenant.

**“Return of Owners’ Capital”** means the payment of the amount, if any, that is necessary to reduce the Unreturned Capital to zero dollars.

**“Second Street Declaration”** shall mean that certain [\_\_\_\_\_] dated [\_\_\_\_\_, 20\_\_], [to be] recorded [as Instrument \_\_\_\_\_] with the Registry, as the same may be amended, modified or supplemented from time to time.

**“Sale Proceeds”** means the gross proceeds of a Sale Transaction received by Tenant or transferor, regardless of the time at which the same are disbursed to or on behalf of Tenant or transferor

**“Sale Transaction”** means any direct or indirect Transfer, whether in a single transaction or in a series of related transactions, of a legal or beneficial interest in this Lease, all or any part of Tenant’s leasehold interest in the Premises or the Tenant Improvements, or any direct or indirect ownership interest in Tenant, except for Exempt Sale Transactions. The term “Sale Transaction” includes, without limitation, except to the extent such transactions or series of transactions constitute an Exempt Sale Transaction, (i) an installment sales agreement wherein Tenant agrees to sell all or any portion of Tenant’s leasehold interest in the Premises or any part thereof for a price to be paid in installments; (ii) an agreement by Tenant leasing all of Tenant’s leasehold interest in the Premises other than for actual occupancy by a tenant thereunder; (iii) if a Restricted Party is a corporation, any merger, consolidation or Transfer of such corporation’s stock or the creation or issuance of new stock in one or a series of transactions, excluding any of the foregoing that (x) is a part of a portfolio sale or other similar multi-asset sale that is not effected primarily for the purpose of transferring the Premises and (y) does not result in a change in Control of Tenant; (iv) if a Restricted Party is a limited or general partnership or joint venture, any merger or consolidation or the Transfer of the partnership interest of any general or limited partner or any profits or proceeds relating to

such partnership interests or the creation or issuance of new limited partnership interests, excluding any of the foregoing that (x) is a part of a portfolio sale or other similar multi-asset sale that is not effected primarily for the purposes of transferring the Premises and (y) does not result in a change in Control of Tenant; (v) if a Restricted Party is a limited liability company, any merger or consolidation or the Transfer of the membership interest of any member or any profits or proceeds relating to such membership interest, excluding any of the foregoing that (x) is a part of a portfolio sale or other similar multi-asset sale that is not effected primarily for the purpose of transferring the Premises and (y) does not result in a change in Control of Tenant; (vi) if a Restricted Party is a trust or nominee trust, any merger, consolidation or the Transfer of the legal or beneficial interest in a Restricted Party or the creation or issuance of new legal or beneficial interests in a Restricted Party, excluding any of the foregoing that (x) is a part of a portfolio sale or other similar multi-asset sale that is not effected primarily for the purpose of transferring the Premises and (y) does not result in a change in Control of Tenant; and (v) any other Transfer that results in a change in Control of Tenant.

“**Scope of Work Document**” shall have the meaning set forth in Section 1.1.

“**Second Dispute Resolution Period**” shall have the meaning set forth in Section 25.3.

“**Senior Executives**” shall have the meaning set forth in Schedule 25.3.

“**Significant Portion**” shall have the meaning set forth in Section 11.1(d).

“**Subordination, Nondisturbance and Attornment Agreement**” or “**SNDA**” shall have the meaning set forth in Section 14.4.

“**Substantial Completion**” or “**Substantially Complete**” shall have the meaning set forth in Section 4.4(a)(ii).

“**Substantial Completion Date**” shall have the meaning set forth in Section 4.4(a)(ii).

“**Subtenant(s)**” shall have the meaning set forth in Section 7.2.

“**Taking**” shall have the meaning set forth in Section 11.1(a).

“**TDEC**” shall have the meaning set forth in Section 4.6(a)i.

“**Tenant**” has the meaning set forth in the Preamble.

“**Tenant’s Confidential Information**” shall have the meaning set forth in Section 28.25(c).

“**Tenant Equipment**” shall mean any and all fixtures, equipment and machinery of every kind and nature whatsoever now or hereafter affixed or attached to the Tenant Improvements, or now or hereafter used or procured for use in connection with the operation, use or occupancy thereof, and the appurtenances thereof, but excluding therefrom all trade fixtures and articles of personal property title to which is vested in the subtenants under any subleases of space therein or in contractors engaged in maintaining the Premises.

“**Tenant Improvements**” shall mean all buildings, structures, driveways, walkways, parking areas, utility facilities, drainage/detention facilities, lighting facilities, signage, landscaping, and other improvements and fixtures located on the Premises from time to time, and any and all alterations, additions, and replacements thereto or thereof from time to time, including, without limitation, the improvements

which are to be constructed by Tenant on the Premises pursuant to this Lease as further described in part in Section 4.1 below (including the Building) and any alterations, additions, or replacements thereto or thereof from time to time.

“**Tenant Interested Party**” shall have the meaning set forth in Section 28.24.

“**Tenant Party/Parties**” shall mean singly, each of, and collectively, Tenant and all of Tenant’s Affiliates, Tenant’s managing agent, and their respective officers, directors, shareholders, partners, members, managers, direct and indirect equity owners, members of any governing boards, employees, contractors, firms, and agents, and any representatives, persons or entities acting on behalf of any of them, and any other person or entity claiming by, through or under any of them, and any of their respective invitees.

Any reference to the “**termination of this Lease**” shall be deemed to include any termination hereof by expiration, default or otherwise.

“**Term**” shall have the meaning set forth in Section 1.1.

“**Transaction Costs**” means any and all customary and reasonable transaction costs associated with a Refinancing Transaction, including, without limitation, brokerage commissions, loan fees and costs (including loan origination fees), title premiums and fees, due diligence costs, attorneys’ fees, consultant fees, transfer taxes, documentary stamp taxes, surtaxes, intangible taxes or other transfer or mortgage taxes, and other closing costs paid by Borrower.

“**Transfer**” shall mean any sale, assignment, conveyance, transfer, exchange, mortgage, pledge, or grant of security interest, including any agreement to sell, assign, convey, transfer, exchange, mortgage, pledge, or grant a security interest, whether made voluntarily or by operation of law or otherwise, and whether made with or without consideration.

“**Transfer Restriction Period**” shall have the meaning set forth in Section 12.2(b).

“**Transfers Allowed as of Right**” shall have the meaning set forth in Section 12.2(a).

“**Treasury Regulations**” shall mean the Treasury Regulations, including Temporary Treasury Regulations, promulgated under the Code, as such regulations may be amended from time to time.

“**Unknown Existing Conditions**” shall have the meaning set forth in Section 23.2(e).

“**Unpermitted Lien**” shall have the meaning set forth in Section 16.1.

“**Unreturned Capital**” means, as to each of the direct or indirect owners of Borrower, the positive difference, if any, between (x) the aggregate capital contributions by such owners to Borrower since the formation of Borrower (in the case of the original owners of Borrower) or since the closing of the last Sale Transaction (in the case of owners after the first Sale Transaction) and (y) the aggregate distributions from Borrower to each of such owners since such formation or the last Sale Transaction (as applicable) on account of their ownership interests in Borrower.

“**Value of Landlord’s Estate**” means the fair market value of the Premises, vacant and unencumbered by any liens and encumbrances (including, without limitation, by this Lease, any Occupancy Sublease or other agreement entered into by Tenant), determined by an independent MAI appraiser selected by Landlord and reasonably approved by Tenant.

“**Value of Tenant’s Estate**” means the fair market value of Tenant’s leasehold estate (including, for the avoidance of doubt, the fair market value of any Tenant Improvements), as determined by an independent MAI appraiser selected by Tenant and reasonably approved by Landlord. For purposes of Section 11.1, such fair market value shall be determined as if this Lease had not been terminated by Tenant pursuant to that Section.

1.3 **Exhibits and Schedules**. The exhibits and schedules listed below and attached hereto are incorporated into this Lease by reference and are to be construed as a part hereof for all purposes.

- Exhibit A-1:** Description of the Land
- Exhibit A-2:** Premises Plan
- Exhibit B:** Description of the Campus
- Exhibit C:** Form of Memorandum of Lease
- Exhibit D-1:** Approved Development Master Plan
- Exhibit D-2:** Scope of Work Document
- Exhibit E-1:** Final Plans and Specifications
- Exhibit E-2:** Obtained Project Approvals
- Exhibit F:** Approved Project Budget
- Exhibit G:** Anticipated Project Schedule
- Exhibit H:** Construction Management Plan
- Exhibit I:** SMWBE Requirements
- Exhibit J:** Amended and Restated Provisions Upon Certain Transfers
- Schedule 4.7:** Construction Insurance
- Schedule 9.1:** Insurance Requirements
- Schedule 25.3:** Senior Executives

## ARTICLE 2

### **LEASE OF PREMISES; DELIVERY**

2.1 **Lease of Premises.** Landlord, for and in consideration of the rent to be paid, the sufficiency of which is hereby acknowledged, and the covenants and agreements hereinafter contained on the part of Tenant to be paid, kept and performed, does hereby demise and lease to Tenant, and Tenant does hereby lease and take from Landlord the Premises subject to (i) the Permitted Encumbrances, and (ii) the terms and conditions set forth herein. The Premises shall have the benefit of (in common with all others entitled thereto) and be subject to all rights, easements, servitudes, rights-of-way, and appurtenances belonging to or appertaining to the Premises and to all covenants, easements, restrictions, agreements and encumbrances affecting the Premises which, in any such case, constitute Permitted Encumbrances. The Premises shall not include Landlord's rights and interest, if any, in and to the fee in the land lying in any public streets and/or private ways abutting or through the Premises, subject to the Applicable Declaration.

2.2 **Delivery of Premises.** Landlord shall deliver to Tenant the Premises in its present condition, "AS IS", "WHERE-IS", it being agreed that Landlord shall not have any obligation to do any work on or with respect to the Premises, or the condition thereof, except as otherwise specifically set forth in the Development Agreement. Tenant acknowledges that Tenant has entered into this Lease making and relying upon its own investigation or the physical, environmental, land use entitlements, economic use, compliance, and legal condition of the premises. Tenant accepts the Premises in the existing condition and state of repair in an "AS-IS," "WHERE-IS" condition, with all faults, and, except as otherwise expressly set forth in this Lease or in the Development Agreement, (A) no representations, statements or warranties, written or oral, express or implied, have been made by or on behalf of Landlord in respect of (i) the Premises, (ii) the status of title thereof, (iii) the physical condition thereof, (iv) the reliability of any information furnished to Tenant, (v) the presence of any Hazardous Materials or other environmental conditions, (vi) the zoning or other laws, regulations, rules and orders applicable thereto, (vii) any Impositions, or (viii) the use that may be made of the Premises, (B) that Tenant has relied on no such representations, statements or warranties, and (C) that Landlord shall in no event whatsoever be liable for any latent or patent defects in the Premises. By entering this Lease, all Permitted Encumbrances shall be conclusively deemed to be satisfactory to Tenant, Tenant shall be conclusively deemed to have waived all objections thereto, and Tenant shall be deemed to have agreed to accept leasehold title to the Premises in the condition thereof as of the Lease Commencement Date subject to the Permitted Encumbrances. None of the terms of this Section 2.2 shall minimize or negate the obligations of Landlord under the Scope of Work Document or the obligations of Owner under the Development Agreement.

2.3 **Declarations and other Permitted Encumbrances; Additional Easements.**

(a) **Declarations and other Permitted Encumbrances.** This Lease and the Tenant's interest in the Premises shall be subject and subordinate to the Applicable Declaration and the other Permitted Encumbrances of record as of the Effective Date. Each of Landlord and Tenant shall have all of the rights and obligations assigned to such party pursuant to the Applicable Declarations and the other Permitted Encumbrances.

(b) **Granting of Additional Easements by Landlord.** At Tenant's reasonable request, made from time to time, Landlord agrees, at no out-of-pocket cost or expense to Landlord, to join (and, to the extent applicable, cause its Affiliates that own any other land within the Campus or adjacent thereto to join) with Tenant in burdening and benefiting the Land and Tenant Improvements with additional, commercially reasonable (i) reciprocal easements permitting passage to and from the Premises to other portions of other structured parking areas outside of the Premises within other portions of the Campus, (ii) easements that may be required by a Governmental Authority and/or utility services provider that are customarily required in connection with the development, use and operation of the Premises and (ii) other easements that may be necessary or desirable in connection with the development, use and operation of the Premises or the overall functioning of the Campus.

(c) Granting of Additional Easements by Tenant. At Landlord's reasonable request, made from time to time, Tenant agrees, at no out-of-pocket cost or expense to Tenant, to reasonably cooperate without obligation to grant any easement or other interests, with Landlord in Landlord's requests to burden and/or benefit the Land and Tenant Improvements with additional, commercially reasonable (i) reciprocal easements permitting passage to and from the Premises to other portions of other structured parking areas outside of the Premises within other portions of the Campus or (ii) easements that are required by a Governmental Authority and/or utility services provider that are customarily required in connection with the development, use and operation of the Premises in connection with the development, use and operation of the Premises or the overall functioning of the Campus, provided that any such easement would not have a material adverse effect on the Project, the Tenant Improvements, or in each case, any part thereof.

(d) Term of Easements. Unless otherwise herein expressly provided, all easements granted or to be granted under this Section 2.3 shall continue for the Term of this Lease, and any replacement thereof or additional extensions thereof, and expire as of the date of termination of this Lease.

(e) Cooperation. The parties agree to cooperate in determining the exact description, nature, need and extent of such easements to be granted under Section 2.3(b) and shall execute and record instruments or documents reasonably acceptable to both Landlord and Tenant evidencing such easements within forty-five (45) days after a request by Tenant. Tenant, and not Landlord, shall be solely responsible for all cost, expense, responsibility, and liability incurred with respect to the easements granted under Section 2.3(b) and evidenced in the applicable easement agreement instrument and Landlord, and not Tenant, shall be solely responsible for all cost, expense, responsibility, and liability incurred with respect to the easements granted under Section 2.3(c) and evidenced in the applicable easement agreement instrument.

(f) Obligations. Landlord and Tenant each agree that its rights and interest herein (and the right and interest of any Subtenant hereunder) are and shall be subject to and with the benefit of this Lease and any easements granted pursuant to this Section 2.3 and each will comply with and observe (and, if applicable, cause Subtenants to comply with and observe) all applicable provisions thereof.

**2.4 Reservation of Rights in Favor of Landlord**. Landlord hereby reserves and retains the right, subject to the rights of Subtenants (including, without limitation, any notice and other applicable provisions under each applicable sublease that would apply to the exercise of such rights, such as limitations regarding access and protocols set forth in any sublease to protect the applicable Subtenant's intellectual property, formulas, operations and confidential information), to enter the Premises for any purposes in this Lease authorized, including to go upon and into the Premises for the purpose of (1) inspecting the performance by Tenant of the terms, covenants, agreements, and conditions of this Lease; (2) to the extent Tenant's responsibility under this Lease or Legal Requirements and Tenant has failed to do so, performing any environmental testing on or about the Land to the extent required by a Governmental Authority pursuant to applicable Legal Requirements in connection with any past or future environmental remediation work on or about the Land; and (3) during the twenty (24) months preceding the expiration of the Term, to show the Premises to prospective purchasers and mortgagees. In the exercise of the foregoing right, Landlord shall not permit interference with Tenant's and the Subtenants' use and enjoyment of the Premises, and the accessing party (i) shall provide Tenant no less than five (5) Business Days' advance written notice, except in the case of an emergency when only such notice to Tenant as reasonably practicable under the circumstances shall be required; (ii) shall avoid (x) interference with the use, occupancy and enjoyment of,

or conduct of operations at, construction of any Tenant Improvements on or performance of any Alterations in, the Premises and (y) adversely affecting the Anticipated Project Schedule; (iii) shall comply with any security and insurance protocols established by Tenant and/or any Subtenant and provided to the accessing party not later than twenty-four (24) hours prior to the initial entry onto the Premises (and provided such protocols are non-discriminatory and equitably enforced by Tenant); (iv) shall not store materials and equipment in the Premises; (v) shall not enter any Premises occupied by a Subtenant except in case of an emergency or otherwise accompanied by a representative of Tenant; (vi) shall not have access to any secure or sensitive portions of a Subtenant's premises except in case of an emergency or otherwise accompanied by a representative of Tenant and/or such Subtenant, and (vii) except in case of an emergency, shall not access the Premises pursuant to the terms of this Section 2.4 more than two (2) times per calendar year. Tenant shall have the right to designate, by written notice to Landlord, areas within the Premises as secure areas to which Landlord shall not have access without being accompanied by a representative of Tenant (except in the case of an emergency).

2.5 **Memorandum of Lease.** Landlord and Tenant agree to execute, deliver and record with the Registry the Memorandum of Lease in the form of **Exhibit C** attached hereto at Tenant's sole cost and expense on or immediately following the Lease Commencement Date. Upon the expiration or earlier termination of this Lease, Landlord shall deliver to Tenant a notice of termination of memorandum lease in form and substance reasonably acceptable to both parties and, unless Tenant has delivered to Landlord written notice that Tenant disputes whether the Lease has been validly terminated, Tenant shall, within thirty (30) days of receipt thereof, execute and deliver the same to Landlord for Landlord's execution and recordation with the Registry. If Tenant fails to deliver an executed termination of memorandum of lease or any dispute thereof as set forth above, and Landlord sends a second notice to Tenant after such initial thirty (30)-day period and Tenant fails to deliver such executed termination of memorandum of lease or dispute thereof within seven (7) days after receipt of such second notice, Landlord may unilaterally record a memorandum of termination in the Registry, which third parties may rely upon as conclusive evidence of the termination of this Lease. Such second notice shall include the following language in bold and capitalized text: "THIS IS A SECOND REQUEST FOR TENANT'S EXECUTION OF THE TERMINATION OF MEMORANDUM OF LEASE UNDER SECTION 2.5 OF THE GROUND LEASE."

### ARTICLE 3

#### **TERM**

3.1 **Term.** The Term of this Lease shall commence on the Lease Commencement Date and end on the Lease Expiration Date, unless terminated sooner pursuant to the terms of this Lease.

3.2 **No Termination.** Tenant shall remain obligated under this Lease in accordance with its terms and shall not take any action to terminate, rescind or avoid this Lease, notwithstanding any action for bankruptcy, insolvency, reorganization, liquidation, dissolution or other proceeding affecting Landlord or any assignee of Landlord or any action with respect to this Lease which may be taken by any trustee, receiver or liquidator or by any court. Except as provided in this Lease, Tenant hereby waives all right to terminate this Lease or to surrender this Lease.



## ARTICLE 4

### CONSTRUCTION OF IMPROVEMENTS

#### 4.1 Improvements.

(a) Tenant Improvements. At Tenant's sole expense and cost, Tenant shall construct or cause to be constructed, in accordance with and subject to the terms and conditions of this Lease, the Approved Plans, the Approved Project Documents, the Project Approvals, and all applicable Legal Requirements upon the Premises, the Tenant Improvements hereafter described in part and at all times during the Term maintain on the Premises the Tenant Improvements, subject to the terms of this Lease, described in part below:

- i. the Building(s);
- ii. all landscaped and planted areas to be located on the Premises, as indicated on the Approved Plans; and
- iii. any other improvements or structures to be located on the Premises, as indicated on the Approved Plans.

(b) Infrastructure. Each of Landlord and Tenant shall perform or cause to be performed all infrastructure work to the extent delegated to it as specified in the Scope of Work Document relating to the Premises, and such work shall be performed in compliance with the applicable terms of the Scope of Work Document.

4.2 Design and Construction Documents. The parties acknowledge and agree that the Tenant Improvements described in Section 4.1 above have been designed in accordance with the Development Agreement, and that Tenant shall construct such Tenant Improvements as specified in the Approved Plans and subject to the Approved Project Budget and the Anticipated Project Schedule, in all material respects, as each may be modified in accordance with the terms hereof and subject further to the terms and provisions of this Lease.

(a) Approved Plans. As of the Lease Commencement Date, Tenant has prepared and submitted to Landlord, and Landlord has approved, the Approved Development Master Plan, which is attached hereto as Exhibit D-1, and the Final Plans and Specifications, a list of which is attached hereto as Exhibit E-1, in accordance with the Development Agreement. The Approved Development Master Plan and the Final Plans and Specifications are collectively referred to herein as the "Approved Plans". Prior to the Substantial Completion of the Project, any changes, modifications, amendments, addendum, or supplements to the Approved Plans shall be made in accordance with the terms of the Development Agreement. If, at any time prior to the Final Completion of the Project, the Development Agreement is no longer in force or effect, any changes, modifications, amendments, addendum, or supplements to the Approved Plans shall be made in accordance with the terms of the Development Agreement last in effect.

(b) Approved Project Budget. As of the Lease Commencement Date, Tenant has prepared the Approved Project Budget in accordance with the Development Agreement, and such Approved Project Budget is attached hereto as Exhibit F. If at any time Tenant changes the Approved Project Budget in any material respect, then (a) Tenant shall promptly deliver or otherwise make available to Landlord such updated Approved Project Budget for the purposes of verifying that such material modification does not reasonably alter Owner's determination

under the Development Agreement that the costs provided for in the Approved Project Budget generally meet the development costs associated with the development of the Project in accordance with the Final Plans and Specifications. Notwithstanding the foregoing, in lieu of making such materially modified Approved Project Budget available to Landlord, Landlord will rely on the written report/certification of the Leasehold Mortgagee to Landlord as to sufficiency of such materially modified Approved Project Budget.

(c) Anticipated Project Schedule. As of the Lease Commencement Date, Tenant has prepared, and Landlord has reviewed, the Anticipated Project Schedule in accordance with the Development Agreement, and such Anticipated Project Schedule is attached hereto as Exhibit G. Any material changes, modification, amendments, addendum, or supplements to the Anticipated Project Schedule shall be made available to Owner.

(d) Construction Management Plan. As of the Lease Commencement Date, Tenant has prepared, and Landlord has approved, the Construction Management Plan, which is attached hereto as Exhibit H. Tenant shall incorporate all relevant portions of the Construction Management Plan into Tenant's contract with its General Contractor or shall otherwise cause its General Contractor to comply with the relevant terms of the Construction Management Plan. *[NTD: To be revised to refer to Construction Management Agreement under Parcel C ground leases.]*

(e) Record Set/As-Built Set. Promptly after Final Completion of the Project, Tenant shall deliver to Landlord (i) a set of as-built architectural, landscaping, site/civil, mechanical, electrical, plumbing and structural plans for the Project; and (ii) an ALTA survey showing the location of the Tenant Improvements, in each case in the form delivered to the Permitted Leasehold Mortgagee.

#### 4.3 Project Approvals.

(a) Project Approvals. As of the Lease Commencement Date and for the initial construction of the Tenant Improvements, Tenant has obtained all of the Approvals listed on Exhibit E-2 attached hereto (collectively, the "Obtained Project Approvals") in accordance with the Development Agreement, and Tenant has provided Landlord with a copy of each Obtained Project Approval to the extent required pursuant to the Development Agreement. Tenant shall obtain, at Tenant's cost and expense, all other Approvals required for the initial construction of the Tenant Improvements to be issued by the applicable Governmental Authorities and, to the extent necessary, any amendments or modifications to any Obtained Project Approval (collectively, the "**Future Project Approvals**"). Notwithstanding the foregoing, for the avoidance of doubt, Tenant shall not be responsible for preparing, filing, pursuing, and obtaining any Approvals (as defined under the Development Agreement) for which Owner is responsible pursuant to the Development Agreement, and any such Approvals shall not constitute Obtained Project Approvals or Future Project Approvals for purposes of this Section 4.3.

(b) Landlord's Approval Rights With Respect To Future Project Approvals. Tenant shall obtain Landlord's approval for all submissions, filings, or applications for Future Project Approvals ("**Future Project Approvals Filings**") if and to the extent Developer would be required to obtain Owner's approval for such filing if it were made in connection with the initial development of the Project, in accordance with the relevant terms of the Development Agreement. If, at any time prior to the Final Completion of the Project, the Development Agreement is no longer in force or effect, any Future Project Approvals Filings shall be made in accordance with the terms of the Development Agreement last in effect. After the Final

Completion of the Project, any Future Project Approvals Filings shall be subject to Landlord's prior written approval, which approval shall not be unreasonably withheld, conditioned or delayed. *[NTD: To substitute this section (b) with the relevant provisions of the MDA once finalized.]*

(c) Not Binding on Governmental Authorities. Landlord's approval of any Approvals under this Section 4.3 is for purposes of this Lease only and will not constitute any other Approvals required from Governmental Authorities under Legal Requirements.

#### 4.4 Initial Construction of Improvements.

(a) Commencement of Construction; Diligent Prosecution of Construction.

i. Commencement. Subject to Force Majeure, Tenant shall Commence Construction of the Tenant Improvements within sixty (60) days after the Lease Commencement Date. For the purposes of this Section 4.4, "Commence Construction" means that Tenant has obtained a grading permit required to commence construction of the Building and has either: (A) begun, or caused to begin, a continuous program of physical on-site preparation for construction (such as erecting necessary construction fencing), subject to the Approvals; or (B) entered into binding agreements or contractual obligations to undertake actual construction of the Tenant Improvements within a contracted period of time, which cannot be canceled or modified without substantial economic loss to the Tenant.

ii. Substantial Completion. Tenant shall diligently proceed with construction so as to cause construction of the Tenant Improvements to be Substantially Completed in accordance with the Approved Plans. The term "Substantial Completion" or "Substantially Complete" shall mean, with respect to the Tenant Improvements, the point at which subject to any subtenant fit out work (i) the Metropolitan Government of Nashville and Davidson County issues a certificate of occupancy (which may be a temporary certificate of occupancy provided that Tenant is diligently pursuing a permanent certificate of occupancy) allowing the use and occupancy of the Building (other than Subtenant spaces) so that the core and shell of the Building can be put into operation (the "**Certificate of Occupancy**") and (ii) the Tenant notifies Landlord in writing to Landlord that Substantial Completion of the Tenant Improvements has been achieved, and delivers to Landlord, together with such notice, a certificate in the form of AIA Document G704 Certificate of Substantial Completion signed by the Architect and addressed to Tenant certifying as to (a) the Substantial Completion of the Tenant Improvements and the date of such Substantial Completion achievement (the "Substantial Completion Date"), and (b) the performance of any remaining work with regard to such Tenant Improvements will not materially interfere with the proposed use of the Building. Tenant shall use commercially reasonable efforts to deliver to Landlord the certificate described in the preceding sentence within fifteen (15) days after Tenant's receipt of the Certificate of Occupancy from the Metropolitan Government of Nashville and Davidson County.

iii. Final Completion. After achievement of Substantial Completion for the Tenant Improvements, Tenant shall use diligent efforts to prosecute all work necessary to achieve Final Completion of the Tenant Improvements in an efficient manner (and in the case of any delays, Tenant shall continue to use diligent efforts to achieve Final Completion of the Tenant Improvements). Tenant shall notify Landlord in writing promptly after Final Completion of the Tenant Improvements has been achieved and shall provide to Landlord, together with such notice, a certificate of payment signed by the Architect and addressed to Landlord certifying that the Tenant Improvements is Finally Complete and the date of such Final Completion achievement. The term "**Final Completion**" or "**Finally Complete**" shall mean, with respect to the Tenant Improvements, the point at which, the

full and final completion of such Tenant Improvements in accordance with the Approved Plans, the Project Approvals, each as the same may have been modified in accordance with this Lease, and all applicable Legal Requirements, as certified by the Architect.

(b) Quality and Performance. Tenant shall perform or cause to be performed all construction and other work required or permitted by this Lease in a good and workmanlike manner in accordance with good construction, architectural, and engineering practices and subject to the terms and conditions of this Lease, the Approved Plans, the Approved Project Documents, the Project Approvals, and all applicable Legal Requirements. Tenant shall be solely responsible for compliance with the Project Approvals for the Tenant Improvements and otherwise satisfying all applicable Legal Requirements for the Tenant Improvements, unless and to the extent Landlord or any of its Affiliates is responsible for the foregoing pursuant to the terms of the Development Agreement.

(c) Progress Reporting. Tenant will keep Landlord reasonably apprised of Tenant's progress in the construction of the Project.

(d) Architect/Landscape Architect/General Contractor. Tenant's architect, landscape architect, and general contractor for the initial construction of the Tenant Improvements (respectively, the "Architect," the "Landscape Architect," and the "General Contractor") have been approved by Owner pursuant to the Development Agreement. Selection of an Architect, Landscape Architect, or General Contractor for any Material Alterations after such initial construction will be subject to Owner's review and approval, not to be unreasonably withheld, provided that Landlord's approval shall be deemed given if Tenant provides evidence that such Architect, Landscape Architect and/or General Contractor meets the qualifications to be pre-approved pursuant to the relevant provisions of the Development Agreement. Selection of an Architect, Landscape Architect, or General Contractor for any Alterations other than Material Alterations after such initial construction will not be subject to Owner's review and approval.

(e) Construction Safeguard. Tenant shall cause to be erected and properly maintained at all times during the construction phase of the Project as required by the conditions and progress of work performed by or at the request of Tenant all necessary safeguards for the protection of works and the public.

(f) SMWBE; Hiring. In connection with the design and construction of the Project, Tenant shall comply with the requirements set forth in the plan annexed hereto as Exhibit I that are applicable to the Project.

(g) Guaranty. Tenant shall deliver to Landlord the Guaranty executed by Guarantor concurrently with the execution of this Lease.

4.5 **Intentionally Omitted**.

4.6 **Soils Management and Tenant Environmental Work**.

(a) Soils Management and Environmental Work. Tenant shall perform or cause to be performed the soils management and environmental remediation work specified in the Scope of Work Document to be performed by Developer at or relating to the Premises (collectively, the "Initial Tenant Environmental Work"); such work shall be performed in compliance with the applicable terms of the Scope of Work Document. Except as expressly provided in the Scope of Work Document, throughout the Term Tenant shall otherwise comply with the provisions of

clauses (i)-(iii) below with respect to any use, treatment, keeping, handling, storage, transport, sale or Release at, on, under or from the Premises of any Hazardous Materials during the Term which arises out of, is the result of, or is related to the acts or omissions of Tenant or its Affiliates, subtenants or invitees on or about the Premises during the Term (collectively, **“Future Tenant Environmental Work”**):

i. Tenant shall ensure that the Premises complies with all applicable Environmental Requirements and reporting any existence or release of any Hazardous Materials discovered in connection with its activities at, on, or about the Premises as anticipated under this Lease to the Tennessee Department of Environment and Conservation (**“TDEC”**) to the extent such reporting is required by and in accordance with the requirements of the TDEC.

ii. For any Future Environmental Condition, Tenant shall perform any investigation, testing, assessment, monitoring, remediation, clean up, removal, disposal, excavation, abatement, encapsulation, barrier construction, venting, containment, risk assessment, or other response actions required under applicable Environmental Requirements in connection with Hazardous Materials located at, on, under or migrating to or from the Premises and/or in connection with completion of the Project thereon, including dewatering activities; and

iii. For any Future Environmental Condition, Tenant shall prepare, execute and file, subject to the Scope of Work Document and approval of the Landlord, or if caused by Tenant, file, as a potentially responsible party and, if applicable, as an “Eligible Person” or as an owner or operator of a downgradient property, all regulatory submittals required in connection with Hazardous Materials discovered at, on, under or migrating to or from the Premises under applicable Environmental Requirements.

(b) Brownfields Tax Credits.

i. Tenant may, at its sole discretion and at its sole cost and expense, enter the Premises into the TDEC Voluntary Oversight and Assistance Program (**“VOAP”**) for the purpose of obtaining a Brownfield Voluntary Agreement (**“BVA”**) and a No Further Action determination (**“NFA”**) with respect to Hazardous Materials or other constituents of environmental concern at or affecting the Premises.

ii. Landlord acknowledges that, in connection with entering the Premises into the VOAP, land use restrictions and other encumbrances will be required by TDEC through a Notice of Land Use Restriction (**“NLUR”**). The form and substance of each NLUR shall be determined by Tenant with Landlord’s approval (which approval shall not be unreasonably withheld. Landlord shall execute the NLUR upon TDEC’s approval and execution. The form and substance of all other documents related to the VOAP, including the BVA, shall be determined by Tenant at its reasonable discretion.

iii. Landlord shall reasonably cooperate with Tenant, at no out-of-pocket expense to Landlord, with respect to entering the Premises into the VOAP and all associated actions.

iv. Tenant may, at its sole discretion, conduct any testing, sampling, or other assessment in connection with entering the Premises into the VOAP.

v. Tenant shall be entitled to any tax credits which are or may become available in connection with the BVA for the Property.

(c) Landlord Environmental Obligations.

i. Landlord shall reimburse Tenant an amount equal to [*NTD: to conform to corresponding provision in MDA*].

ii. For any environmental condition occurring at the Premises after the Effective Date which is not an Existing Environmental Condition and which is caused by Landlord or any Landlord Affiliate, Landlord (or at Tenant's option, Tenant at Landlord's sole cost) shall perform any investigation, testing, assessment, monitoring, remediation, clean up, removal, disposal, excavation, abatement, encapsulation, barrier construction, venting, containment, risk assessment, or other response actions required under applicable Environmental Requirements in connection with Hazardous Materials located at, on, under or migrating to or from the Premises and/or in connection with completion of the Project thereon, including dewatering activities.

Nothing in this Section 4.6 shall negate or minimize the Developer's obligations under the Development Agreement with respect to the subject matter of the provisions of this Section 4.6.

4.7 **Construction Insurance.** The provisions of **Schedule 4.7** annexed hereto are incorporated herein by reference with regard to the insurance required to be maintained by Tenant, General Contractor, and Landlord in connection with the design and construction of the Project pursuant to this Article 4.

4.8 **Alterations.**

(a) Permitted Alterations. Following Final Completion of the Project, Tenant may undertake at any time and from time to time changes, renovations, reconstruction, repairs, and alterations to the Land and the Tenant Improvements (collectively, "**Alterations**") in accordance with this Section 4.8. Tenant shall be entitled to make any Alterations to the Premises; provided, however that Tenant shall not make any Material Alteration without the prior approval of Landlord, which approval shall not be unreasonably conditioned, withheld or delayed.

(b) Landlord's Review and Approval of Material Alterations.

i. With respect to any Material Alteration, Landlord shall have twenty-five (25) days from its receipt of Tenant's underlying plans for such Material Alteration to review and approve or object to such plans and specifications, in each case in Landlord's reasonable discretion. If Landlord objects in writing to such plans within such twenty-five (25)-day period and if Tenant desires to continue its pursuit of the proposed Material Alterations, then Tenant may revise the plans and specifications to address Landlord's concerns and resubmit the revised plans and specifications for Landlord's reasonable review and approval, and the process shall be repeated until Landlord is reasonably satisfied with the revised plans for the proposed Material Alterations, Landlord's approval is deemed to have been granted in accordance with Section 4.8(b)(ii) below, or Tenant otherwise withdraws its proposal.

ii. With respect to any Material Alteration, Landlord's reasonable approval shall be deemed to have been granted if (i) such plans and specifications are not disapproved by Landlord in writing within the twenty-five (25) day period described in Section 4.8(b)(i) and (ii) Tenant sends a second notice to Landlord after such initial twenty (20) day period and Landlord fails to disapprove such plans and specifications within ten (10) days after receipt of such second notice. Such second notice shall include the following language in bold and capitalized text: "THIS IS A SECOND APPROVAL REQUEST FOR LANDLORD'S REASONABLE APPROVAL OF TENANT'S MATERIAL ALTERATIONS UNDER SECTION 4.8(b) OF THE GROUND LEASE."

LANDLORD'S FAILURE TO RESPOND TO THIS SECOND APPROVAL REQUEST WITHIN SEVEN (7) BUSINESS DAYS SHALL BE DEEMED LANDLORD'S APPROVAL OF THE APPROVAL MATTER REFERENCED HEREIN."

iii. All Material Alterations for which Landlord's consent has been received shall be performed substantially in accordance with the plans approved (or deemed approved) by Landlord pursuant to this Section 4.8(b), and no material amendments or material additions to such plans, to the extent constituting a Material Alteration, shall be made without the prior written consent of Landlord in accordance with the terms of this Section 4.8(b).

(c) Approvals for Material Alterations. Tenant shall obtain Landlord's approval, which shall not be unreasonably withheld, conditioned, or delayed, for all submissions, filings, or applications for Approvals for any Material Alterations. Tenant shall procure, at its sole cost and expense, any and all necessary Approvals required with respect to all such Alterations performed pursuant to this Section 4.8, and Tenant shall cause such work to be done in conformance with all applicable Approvals and Legal Requirements, and in a good and workmanlike manner, using materials and equipment at least equal in quality and class to the original quality of the Tenant Improvements that are being replaced.

(d) Costs of Alterations. Tenant shall be solely responsible for all costs and expenses incurred with respect to all Alterations performed pursuant to this Section 4.8, and Landlord shall not incur any out-of-pocket third-party costs under this Section 4.8 (other than out-of-pocket costs for which Tenant agrees in writing to reimburse Landlord). In addition to the foregoing, Tenant shall reimburse Landlord for all such actual and reasonable out-of-pocket, third party architectural and engineering expenses reasonably incurred by Landlord in connection with its review of any proposed Alterations that require Landlord's consent pursuant to the terms of this Lease, including the actual reasonable fees and expenses of any architect or engineer or other consultants employed for such purposes. Such reimbursement as required by this Section 4.8(d) shall be considered Additional Rent and payable to Landlord not later than thirty (30) days following receipt of an itemized invoice therefor. Any amounts not paid to Landlord within such thirty (30) days will accrue interest at the Default Rate until paid.

(e) Compliance with Lease Provisions. With respect to any Alterations, Tenant shall comply with the terms and conditions of this Lease, including without limitation, Section 4.4(e), Section 4.4(f), Section 4.6, Section 4.7, Section 7.5, Article 9, and Article 23 with respect to such Alterations, in each case to the extent applicable.

(f) As-Built Plans. Upon Landlord's request, after completion of the applicable Material Alterations, Tenant shall provide Landlord with "as-built" plans, if any, for the Premises (as then constructed) that were prepared in connection with such Material Alterations and that are in Tenant's possession or control (or as may be reasonably obtained without out-of-pocket cost to Tenant), which may be provided on a data site established by Tenant (which data site need not be maintained by Tenant for longer than thirty (30) days).

## ARTICLE 5

### RENT

5.1 **Base Rent**. Commencing on the Rent Commencement Date, Tenant shall pay to Landlord as Base Rent for the Premises, the annual amount set forth in Section 1.1, as such amount may be adjusted for each year after the first Lease Year, as provided in Section 5.2. Base Rent shall be paid in equal monthly

installments, in advance on, or before, the first day of each calendar month during the Term. If there is a partial month at the beginning of the first Lease Year, the Base Rent for such partial month shall be a pro rata amount for the actual number of days in such partial month, such partial month Base Rent shall be paid on the Rent Commencement Date, and such partial month Base Rent will not be included in the first Lease Year Base Rent for purposes of the adjustments described in section 5.2 below.)

5.2 **Base Rent Adjustments.** Base Rent shall be subject to an annual upward adjustment in accordance with this Section 5.2 (the “**Base Rent Adjustment**”). For each Lease Year after the initial Lease Year, Base Rent shall be equal to (i) the Base Rent in effect for the preceding Lease Year, plus (ii) an amount equal to the product of (x) the Base Rent in effect for the preceding Lease Year and (y) the applicable Base Rent Escalator. The first such adjustment shall become effective commencing on the first day of the second Lease Year, and subsequent adjustments shall become effective on the first day of every successive Lease Year for so long as this Lease continues in effect. Annual increases in Base Rent shall be compounding and cumulative. Not less than sixty days prior to the start of each Lease Year, Landlord shall provide Tenant with notice of the Base Rent Adjustment for such Lease Year and Tenant shall have thirty (30) days to send Landlord notice of any disagreement over Landlord’s determination of such adjustment. Tenant’s failure to respond within such thirty (30)-day period shall be deemed Tenant’s acceptance of Landlord’s determination of the Base Rent Adjustment. Not less than sixty (60) days prior to the first day of the tenth Lease Year, and each tenth Lease Year thereafter, Landlord shall provide Tenant with notice of Landlord’s calculation of the Base Rent Escalator, along with any backup information used by Landlord in determining the Base Rent Escalator and Tenant shall have thirty (30) days to send Landlord notice of any disagreement over Landlord’s determination of the Base Rent Escalator. Tenant’s failure to respond within such thirty (30)-day period shall be deemed Tenant’s acceptance of Landlord’s calculation of the Base Rent Escalator and the Base Rent Adjustment. If Tenant disagrees with the Landlord’s calculation of the Base Rent Escalator or the Base Rent Adjustment, and the Parties are unable to agree on the Base Rent Adjustment or Base Rent Escalator within fifteen (15) Business Days of Landlord’s receipt of Tenant’s notice, the dispute will be resolved in accordance with the dispute resolution procedure set forth in Article 25 hereof.

5.3 **Additional Rent.** From and after the Lease Commencement Date, Tenant shall also pay and discharge prior to delinquency all Impositions and insurance premiums required to be paid under this Lease and all other sums, charges, costs and expenses of every kind and nature that Tenant in any of the provisions of this Lease agrees to pay to Landlord (collectively, the “**Additional Rent**”).

5.4 **Payment of Rent.** Rent shall be paid by ACH or wire transfer to Landlord (but in no event may Rent be paid in cash), without abatement, deduction or offset, in lawful money of the United States of America to the address set forth below or to such other person or at such other place as Landlord may from time designate in writing.

5.5 **Future Participation Rent.**

(a) Tenant shall pay Landlord, within five (5) Business Days following the closing of any Sale Transaction or a Refinancing Transaction, [\_\_\_\_\_] percent (\_\_\_\_%)<sup>1</sup> of the Sale Proceeds from such Sale Transaction or [\_\_\_\_\_] percent (\_\_\_\_%)<sup>2</sup> of the Excess Refinancing Proceeds from such Refinancing Transaction, as applicable. The foregoing payments to

---

<sup>1</sup> NTD: Insert 0.75% for any market residential ground lease; insert 1% for any other ground lease (other than 100% affordable; parties to allocate proceeds for any 100% affordable building between residential and retail with 0% of Sales Proceeds for residential and 1% for retail).

<sup>2</sup> NTD: Insert 0.75% for any market residential ground lease; insert 1% for any other ground lease (other than 100% affordable; parties to allocate proceeds for any 100% affordable building between residential and retail with 0% of Refi Proceeds for residential and 1% for retail).



Landlord are referred to herein as the “**Future Participation Rent.**” For avoidance of doubt, in no event shall Tenant be obligated to pay Future Participation Rent on both Refinancing Proceeds and Sale Proceeds arising out the same transaction.

(b) Following the consummation of any Sale Transaction or Refinancing Transaction, Tenant shall provide Landlord with a certification of the amount of Future Participation Rent due hereunder, together with the calculation of the same and reasonable back up materials evidencing the same (which may be redacted as reasonably required to protect confidential information that is not necessary for such calculation). For a period of twelve (12) months following the final payment of Future Participation Rent in accordance with the applicable Sale Transaction or Refinancing Transaction, Landlord shall have the right to review and copy the applicable settlement documents, including the applicable, relevant transfer documents and closing statements, and books and records necessary for the calculation of Future Participation Rent, whether such books and records are the property of or under the possession or control of Tenant, any holder of a direct or indirect beneficial interests in Tenant or any entity holding a direct or indirect a beneficial interest in Tenant, to verify the calculation of the amounts due hereunder, with any such information reviewed by Landlord being treated as Tenant’s Confidential Information pursuant to Section 28.25(c) hereof. Any dispute as to the determination of Future Participation Rent will be resolved in accordance with the dispute resolution procedure set forth in Article 25 hereof.

5.6 **Absolute Net Lease.** This Lease shall be deemed and construed to be an “absolute net lease” and it is intended that, except where specifically provided in this Lease, Tenant, and not Landlord, shall bear all costs, expenses, responsibilities, and obligations of every kind and nature whatsoever foreseen and unforeseen relating to the condition, use, operation, management, maintenance, repair, restoration, or replacement of the Premises and all improvements and appurtenances related thereto. Except as otherwise expressly provided in this Lease, Tenant shall pay all sums payable hereunder without notice or demand, and without set-off, abatement, suspension or deduction.

## ARTICLE 6

### **PAYMENT OF IMPOSITIONS**

6.1 **Payment of Impositions.** Tenant shall pay, or cause to be paid, on or before the last day on which they may be paid without penalty or interest, and discharge or cause to be discharged all Impositions, which at any time during, prior to or after (but attributable to a period falling within) the Term are (i) assessed, levied, confirmed, imposed upon, accrue or would otherwise become due and payable out of or in respect of, or would be charged with respect to, the Premises or any document to which Tenant is a party creating or transferring an interest or estate in the Premises, the use and occupancy thereof by Tenant, or this transaction, and/or (ii) encumbrances or liens on: (a) the Premises; (b) any other appurtenances of the Premises; or (c) any personal property, Tenant Equipment or other facility used in the operation thereof. Notwithstanding the foregoing, if any Imposition may be paid, at the option of the taxpayer, in installments, then Tenant may pay the same in installments including any interest which accrues thereon, and Tenant shall only be responsible for the portion of Imposition properly allocable to the Term regardless of when an installment (and/or portions thereof) is due and payable. Any rebate made on account of any Imposition paid by Tenant shall belong to and be paid to Tenant, for Tenant’s account.

6.2 **Permitted Contests.** Tenant may, upon prior written notice to Landlord, at Tenant’s option and at Tenant’s sole cost and expense, protest, appeal, or institute such other proceedings as Tenant may deem appropriate to effect a reduction of Impositions or personal property assessments. Notwithstanding the foregoing, Tenant shall not be required to pay any Impositions the amount, validity or payment of which

after notice to Landlord is being contested, in good faith, by appropriate legal proceedings, provided that Tenant must provide such reasonable security as may be requested by Landlord to ensure proper payment of such Imposition to the extent required to prevent any sale or forfeiture of the Premises by reason of such nonpayment, and Tenant hereby indemnifies Landlord for any such liability or penalty.

6.3 **Apportionment of Premises Not Separately Taxed.** In the event that the Premises are not separately taxed or assessed for or with respect to any applicable taxation period, then, in that event, the Impositions as levied shall be apportioned for the Premises in such a manner that Tenant shall pay to the Landlord only an equitable portion of any such Imposition properly apportioned or allocated to the Premises upon receipt from Landlord of a bill for such period.

6.4 **Receipt for Payment of Impositions.** Tenant shall within ten (10) Business Days of payment and in any event on Landlord's request, deliver to Landlord copies or duplicate receipts (or, if the same are not available, other materials reasonably acceptable to Landlord) showing the timely payment of all Impositions paid by Tenant as required by this Lease.

6.5 **Special Provisions Regarding Property Taxes.** Tenant acknowledges and agrees that, pursuant to Tenn. Code. Ann. § 67-5-203(e), ad valorem property taxes will be assessed against the Premises, including (without limitation) the Land, as if Tenant were the fee owner thereof, notwithstanding the fact that Landlord owns fee simple title to the Land. If, at any time during the Term, Tenn. Code. Ann. § 67-5-203(e) or any other applicable Legal Requirements are amended or repealed so as to make the Land or any other portion of the Premises exempt from ad valorem property taxes, unless otherwise agreed to by Landlord and Tenant, Tenant shall pay to Landlord, as Additional Rent each year, an amount equal to the positive difference between (x) the ad valorem property taxes that would be due if fee simple title to the Land were owned by Tenant, and not Landlord, and (y) the ad valorem property taxes actually paid by Tenant for the Premises for such year. The provisions of this Section 6.5 will apply only so long as fee title to the Land is held by Metro, the East Bank Authority, or any other governmental or quasi-governmental entity that is exempt from ad valorem property taxes.

## ARTICLE 7

### **USE; COMPLIANCE WITH LEGAL REQUIREMENTS; MAINTENANCE AND REPAIRS**

7.1 **Permitted Use.** Throughout the Term and subject to all provisions and limitations contained in this Lease, Tenant shall have the right to occupy and/or use the Premises only for the Permitted Uses and for no other uses.

7.2 **Prohibited Uses.** Tenant shall not occupy and/or use the Premises or permit any part thereof to be used or occupied for the Prohibited Uses or any unlawful use. Upon discovery of any occupancy or use of the Premises for a Prohibited Use, Tenant shall use and exercise reasonable and diligent efforts to compel the discontinuance of such use by any subtenants, operators, licensees, concessionaires, and other occupants of the Premises (individually, a "**Subtenant**"; and collectively, "**Subtenants**"), other than Landlord, that are engaging in, or permitting, such Prohibited Use.

7.3 **No Adverse Possession.** Except for acts or omissions of Landlord or parties claiming by, through or under any of the Landlord Parties, Tenant shall not suffer or permit the Premises or any portion thereof to be used by the public in such manner as may result in a claim of adverse possession by the public, as such, or of implied dedication of the Premises or any portion thereof.

7.4 **Compliance with Legal Requirements.** Throughout the Term, Tenant shall, at Tenant's sole cost and expense, comply in all material respects with any and all applicable Legal Requirements then

affecting the Premises. Except as expressly set forth herein or in the Development Agreement and/or the Scope of Work Document, it is intended that Tenant bear the sole risk of compliance with any and all applicable Legal Requirements affecting the Premises and Landlord shall not be liable for their enforcement, except as resulting from the acts or omissions of the Landlord Parties. Tenant, at its option and sole expense, shall have the right to contest in good faith by appropriate legal proceedings, and delay compliance thereof during the pendency of such proceedings, the validity or applicability of any applicable Legal Requirement, provided Tenant pays to Landlord on request security in an amount reasonably estimated by Landlord to effect compliance and pays any penalties accruing if the contest of the Legal Requirement is not upheld.

7.5 **Maintenance and Repairs.** Throughout the Term and at Tenant's sole cost and expense, Tenant shall (i) take good care of the Premises (including, without limiting the generality of the foregoing, the Tenant Improvements), (ii) put, keep, and maintain the Premises in good, safe, clean, and sanitary order, repair, operation, maintenance, and condition, (iii) promptly make or cause to be made all necessary repairs therein, thereon, and thereto, interior and exterior, structural and nonstructural, ordinary and extraordinary, foreseen and unforeseen, to keep the same in good, safe, clean, sanitary and working order and condition (ordinary wear and tear and damage excepted), and to comply in all material respects with all applicable Legal Requirements, and whether or not necessitated by wear and tear, obsolescence or defects, latent or otherwise. The necessity and adequacy of repairs to be made shall be measured by a first-class standard for buildings of similar age, construction and use in the Nashville, Tennessee metropolitan area. When used in this Lease, the term "repairs" shall include all alterations, additions, installations, replacements, removals, renewals and restorations. Tenant shall perform all necessary or required repairs to the Premises (including, without limitation, except to the extent the responsibility of any other Person pursuant to the Development Agreement or Declarations), the landscaping and parking areas, driveways, entrance and exit ramps, sidewalks, curbs, and other publicly accessible spaces) in a quality and class equal to the original work and in compliance with all Legal Requirements, as then in force. Except as otherwise expressly set forth in this Lease or the Development Agreement, Tenant assumes the full and sole responsibility for the condition, operation, repair, alteration, improvement, replacement, maintenance and management of the Premises, including the impact of the condition, operation, repair, alteration, improvement, replacement, maintenance and management of the Premises on the existing utilities within the Premises.

7.6 **Waste; Nuisance.** Tenant shall not, either with or without negligence, injure, damage or otherwise harm the Premises or any part of component thereof; commit any nuisance; permit the emission, release or other escape of any Hazardous Materials or allow the storage or use of such Hazardous Materials, in each case, in any manner not sanctioned by law; nor shall Tenant bring or allow to be brought onto the Premises any such Hazardous Materials except to use in the ordinary course of business of Tenant or its Subtenants and in accordance with applicable Legal Requirements, nor make, allow or suffer any intentional physical waste whatsoever to the Premises.

7.7 **Repairs by Landlord.** If Tenant fails to perform its obligations under Section 7.4 or Section 7.5 above, then Landlord may give written notice to Tenant and any Permitted Leasehold Mortgagee and/or Permitted Mezzanine Lender of such failure. If Tenant fails to remedy such failure within thirty (30) days after receipt of such written notice, or at any time in the event of an emergency, Landlord shall have the right, at its option (but without any obligation), to make any repairs, replacements, or renewals to the Premises necessary (i) to maintain the Premises in a safe condition, (ii) to cure any violation of Legal Requirements that Landlord reasonably deems necessary or advisable to prevent imminent harm to public health or safety or (iii) to abate any violation of Environmental Law. Landlord, and its authorized representatives may enter the Premises for such purpose and take all such action as may be necessary therefor, and such entry shall not constitute or be deemed to be an eviction of Tenant. Tenant shall pay to Landlord on demand any out-of-pocket third-party costs reasonably incurred by Landlord in making such

repairs, replacements, and renewals, and if not paid within thirty (30) days of Tenant's receipt of such demand, together with interest at the Default Rate on such amounts until paid.

## ARTICLE 8

### UTILITIES

8.1 **Tenant's Responsibility For Utilities.** Landlord and Tenant acknowledge and agree that their respective obligations with respect to the initial utilities that will serve the Premises are set out in the Scope of Work Document. Tenant shall arrange, provide and promptly pay directly for all utilities used upon or furnished to the Premises during the Term, including, without limitation, water, sewer, gas, electricity, telephone, data and other energy or utility service. Tenant acknowledges and agrees that Landlord shall have no responsibility or liability under the terms and conditions of this Lease for any interruption, curtailment, stoppage, or suspension of utilities, except to the extent caused by Landlord or its Affiliates, agents or contractors. Tenant shall also, at its sole cost and expense, procure any and all necessary Approvals required for the lawful and proper installation and maintenance upon the Premises of all appropriate utility or other connections to the applicable utility infrastructure.

## ARTICLE 9

### INSURANCE AND INDEMNITY

9.1 **Insurance Requirements.** Tenant shall maintain or cause to be maintained, where applicable, in full force and effect throughout the Term the insurance required pursuant to **Schedule 9.1** annexed hereto.

9.2 **Intentionally Omitted.**

9.3 **Waiver of Subrogation.** Tenant and Landlord (to the extent Tenant so waives its rights) hereby waive any and every claim for recovery from the other for any and all loss or damage to the Tenant Improvements or to the contents thereof, whether such loss or damage is due to the negligence of Landlord or Tenant or their respective agents or employees, which loss or damage is insured pursuant to this Lease by valid and collectible property insurance policies (or would have been covered by the insurance such Party is required to carry under this Lease); provided that Landlord and Tenant each agree to give written notice of the terms of this mutual waiver to each insurance company which has issued, or in the future may issue, policies of physical damage insurance to it, and to have said insurance policies properly endorsed to prevent the invalidation of said insurance coverage by reason of said waiver; and provided further that such insurance company waives all rights of subrogation which it might have against Landlord or Tenant, as the case may be.

9.4 **Tenant's Indemnity.** Tenant shall not do or permit any act or thing to be done upon the Premises which may subject Landlord to any materially increased liability or responsibility for injury, damage to Persons or property, or to any increased liability by reason of a failure of Tenant to comply with any Legal Requirement as required pursuant to this Lease, and shall exercise such control over the Premises so as to protect Landlord against any such increased liability. Tenant shall indemnify and save each of the Landlord Parties harmless from and against any and all liabilities, suits, obligations, fines, damages, penalties, claims, costs, charges and expenses, including, without limitation, reasonable engineers', architects' and attorneys' fees, court costs and disbursements (collectively, the "**Liabilities**"; individually, a "**Liability**") which are imposed upon or incurred by or asserted against any Landlord Party during the Term and arising out of the Premises or any act of the Tenant Parties related to the Premises, including, the following:

(a) any demolition or razing or construction of the Tenant Improvements or any other work or thing done in or on the Premises or any part thereof;

(b) any use, alteration, repair, condition, operation, maintenance or management of the Premises or any part thereof (except to the extent such work is the responsibility of Landlord or its Affiliates hereunder or under the Development Agreement);

(c) any wrongful or negligent act or omission with respect to the Premises on the part of Tenant or any Tenant's Subtenant or any of its or their respective officers, agents, employees or licensees;

(d) any accident, injury (including death at any time resulting therefrom) or damage to any Person or property occurring in or on the Premises or any part thereof;

(e) any failure on the part of Tenant to pay Additional Rent or to perform or comply with any of the covenants, agreements, terms or conditions contained in this Lease on Tenant's part to be performed or complied with; and

(f) any lien or claim which may be alleged to have arisen against or on the Premises, or any lien or claim which may be alleged to have arisen out of this Lease and created or permitted to be created by Tenant against any assets of Landlord under applicable Legal Requirements, or any liability which may be asserted against Landlord with respect thereto;

provided, however, that the foregoing indemnification shall not extend to indirect, consequential, special, punitive or speculative damages (including, but not limited to, loss of profit or business loss or interruption) and shall exclude all Liability to the extent (i) that is caused by the act, omission, gross negligence or willful misconduct of, or the exercise of a reserved right by, a Landlord Party and/or Owner, (ii) that is a liability or obligation of Landlord, Owner or any of their respective Affiliates under any Permitted Encumbrance, the Development Agreement, or this Lease (including, without limitation, the Scope of Work Document), or (iii) otherwise constitutes an Excluded Claim. Except as otherwise expressly provided herein or in the Development Agreement or the Scope of Work Document, Tenant hereby waives, and hereby releases and forever discharges each of the Landlord Parties of and from, any and all claims, actions, causes of action, demands, rights, liabilities, obligations, damages, losses, diminution in value, costs or expenses of any kind or nature whatsoever, whether accrued or unaccrued, actual or contingent, known or unknown, including any claim for contribution, cost or recovery, which Tenant now has or may have against any of the Landlord Parties, arising out of, resulting from or relating in any way to the Premises or the condition thereof prior to or as of the Lease Commencement Date. Upon notice from Landlord, Tenant shall defend the Landlord Parties in any action or proceeding brought in connection with any such Liability for which Tenant is obligated to indemnify Landlord Parties as set forth above, with counsel reasonably satisfactory to Landlord.

9.5 **Tenant's Indemnity Unrelated to Insurance.** The obligations of Tenant under Section 9.4 above shall not be affected in any way by the absence of covering insurance or by the failure or refusal of any insurance carrier to perform any obligation on its part under insurance policies affecting the Premises or any part thereof.

9.6 **Tenant's Assumption of Risk and Waiver.** To the extent not prohibited by applicable law and except as expressly set forth in this Lease, none of the Landlord Parties shall be liable for any damage either to person or property or resulting from the loss of use thereof, which damage is sustained by Tenant or by any other person claiming by or through Tenant with respect to matters occurring in or about the Premises, or due to the occurrence of any accident or event in or about the Premises, and Tenant, as a

material part of the consideration to Landlord for this Lease, hereby assumes all risk of damage to property or injury to person in, on or about the Premises from any cause whatsoever (except to the extent otherwise expressly provided in the Development Agreement (including, without limitation, Owner's indemnification obligations under Section 8.1.2 and Schedule 8.2.2 of the Development Agreement). Tenant agrees that all personal property upon the Premises shall be at Tenant's risk only, and that Landlord shall not be liable for any loss or damage thereto or theft thereof. The foregoing limitation on liability shall not apply to any claims, damages, liabilities, costs or expenses arising out of the acts, omissions, negligence or willful misconduct of, or exercise of reserved rights hereunder or under the Development Agreement or the Declarations by any Landlord Party.

9.7 **Landlord's Release.** Landlord hereby releases each of the Tenant Parties to the extent of Liabilities arising out of or related to Landlord's intentional acts or omissions constituting a failure to perform or comply with any of Landlord's covenants, agreements, terms or conditions contained herein and required to be performed or complied with during the Term. If (i) Landlord consummates a Landlord Transfer to a Person that is neither an Affiliate of Landlord nor a governmental or quasi-governmental entity, or (ii) (ii) the Constitution of the State of Tennessee is amended to expressly permit political subdivisions of the State of Tennessee to provide indemnification, then from and after the closing of such assignment or the date of such amendment (as applicable), this Section 9.7 shall automatically be amended and restated to provide as follows:

9.7 **Landlord's Indemnity.** Landlord shall indemnify and save each of the Tenant Parties harmless from and against any Liabilities arising out of or related to Landlord's intentional acts or omissions constituting a failure to perform or comply with any of Landlord's covenants, agreements, terms or conditions contained herein and required to be performed or complied with during the Term, except to the extent that any Liability (i) is caused by the act, omission, gross negligence or willful misconduct of, or the exercise of a reserved right by a Tenant Party hereunder or under the Development Agreement, (ii) is a liability or obligation of Tenant or any of its Affiliates under the Development Agreement, or this Lease, or (iii) otherwise constitutes an Excluded Claim. Upon notice from Tenant, Landlord shall defend the Tenant Parties in any action or proceeding brought in connection with any such Liability for which Landlord is obligated to indemnify Landlord Parties as set forth above, with counsel reasonably satisfactory to Tenant.

9.8 **Survival.** The provisions of this Section 9.8, Section 9.7, Section 9.6, Section 9.5, and Section 9.4 above shall survive the Lease Expiration Date.

## ARTICLE 10

### **DAMAGE TO OR DESTRUCTION OF THE PREMISES**

10.1 **Continuance of Lease.** Tenant agrees that, in case of damage to or destruction of any part of the Premises by fire or other casualty of any kind or nature, or should any part of the Premises become untenantable or unusable for any reason and whether or not insurance proceeds are available, this Lease shall not terminate nor shall there be any abatement or reduction in the rent or other charges payable by Tenant, nor shall the respective rights or obligations of Landlord and Tenant be affected in any way, except as specifically provided in this Lease.

10.2 **Damage or Destruction.** If all or any part of the Tenant Improvements are destroyed or damaged in whole or in part by fire or other casualty (whether or not insured) of any kind or nature, ordinary or extraordinary, foreseen or unforeseen, Tenant shall give Landlord prompt notice thereof (except with respect to partial damage the reasonably estimated cost of repair of which is less than \$1,000,000.00 (as

adjusted on each anniversary of the Lease Commencement Date for any increases in CPI during the prior year)), and Tenant, whether or not such damage or destruction shall have been insured or insurable, and whether or not insurance proceeds, if any, shall be sufficient for the purpose, and whether or not the Leasehold Mortgagee, if any, shall permit such insurance proceeds to be used for such repairs, alterations, restorations, replacements and rebuilding (collectively, "Restoration"), with due diligence, shall repair, alter, restore, replace and rebuild (collectively, "Restore") the same, at least to the extent of the value and as nearly as practicable to the character of the Tenant Improvements existing immediately prior to such occurrence. Landlord, in no event, shall be called upon to Restore the Tenant Improvements, as now or hereafter existing, or any portion thereof or to pay any of the costs or expenses thereof. If Tenant fails or neglects to Restore with commercially reasonable diligence the Tenant Improvements or the portion thereof damaged or destroyed, or, having so commenced such Restoration, fails to complete the same with commercially reasonable diligence in accordance with the terms of this Lease, then, in addition to any other right or remedy, Landlord may complete such Restoration at Tenant's expense. Upon Landlord's election to so complete the Restoration, Tenant promptly shall pay to Landlord all insurance proceeds which shall have been received by Tenant, minus those amounts, if any, which Tenant shall have applied to the Restoration, and if such sums, together with sums on deposit with the Depository which are available for the purpose of Restoration, are insufficient to complete the Restoration, Tenant, on demand, shall pay the deficiency to Landlord. Each Restoration shall be done in accordance with the provisions of this Lease.

Notwithstanding the foregoing to the contrary, in the event that 50% percent or more of any Building on the Premises (as determined by gross square footage) is damaged or destroyed any casualty, or if insufficient funds are available to Tenant to complete the necessary Restoration, Tenant may, subject to the rights of any Leasehold Mortgages and Mezzanine Lenders, elect to demolish all or a portion of the affected Tenant's Improvements and leave the applicable portion of the Premises in safe and sightly condition consistent with first class standards so long as (i) Tenant thereafter uses commercially reasonable efforts to commence and pursue the redevelopment of the affected areas of the Premises, subject to Landlord's review and approval to the extent that Owner would be entitled to the same under the Development Agreement, including by preparing a redevelopment plan, submitting the necessary applications for such redevelopment, and marketing the affected areas for sublease and (ii) continues to pay Rent unabated in accordance with the terms of this Lease. If Tenant has not secured all Approvals and necessary financing for, and commenced the physical work of replacement or restoration (in accordance with this Lease) of the affected Tenant's Improvements within seven (7) years after the date of such casualty with Tenant's Improvements at least equal to 50% of the gross square footage of the demolished Tenant's Improvements, and thereafter diligently continued such work to completion, or, notwithstanding the provisions of this Section 10.2, has not in any event completed such work within a period equal to the initial construction schedule for such work as provided in the construction contract for the same, plus an additional period equal to 50% of such schedule, in each case subject to extension for Force Majeure Events, such failure shall be deemed to be an Event of Default (without any additional notice or cure period).

**10.3 Payment for Restoration.** Subject to the provisions of Section 10.4, the Depository shall pay over to Tenant from time to time, upon the following terms, for the purpose of Restoration, any moneys which may be received by Depository from insurance provided by Tenant (other than rent insurance) (collectively, the "**Restoration Funds**"); provided, however, that Depository, before paying such moneys over to Tenant, shall be entitled to reimburse itself, Tenant (and any Leasehold Mortgagee or Mezzanine Lender) and Landlord therefrom to the extent, if any, of the expenses paid or incurred by any such party in the collection of such moneys. Such Restoration shall be done in accordance with, and subject to, the provisions of Article 4 (if applicable) and Article 9. Prior to the making of any Restoration, Tenant shall furnish Landlord with an estimate of the cost of such Restoration, prepared by a licensed professional engineer or registered architect approved by Landlord which approval shall not be unreasonably withheld or delayed, and provided that any architect approved under the Development Agreement is approved for the purposes of this Section 10.3. The Restoration Funds shall be paid to Tenant from time to time thereafter

in installments as the Restoration progresses upon application to be submitted from time to time by Tenant to Depository and Landlord showing the cost of work, labor, services, materials, fixtures and equipment incorporated in the Restoration, or incorporated therein since the last previous application, and paid for by Tenant or then due and owing. If any vendors', mechanics', laborers', or materialmen's lien is filed against the Premises or any part thereof, Tenant shall not be entitled to receive any further installment until such lien is satisfied or otherwise discharged or a reserve or other security is delivered by Tenant to Landlord or any Leasehold Mortgagee or Mezzanine Lender. The amount of any installment to be paid to Tenant shall be in such proportion to the total Restoration Funds as the cost of work, labor, services, materials, fixtures and equipment theretofore incorporated by Tenant into the Restoration bears to the total estimated cost of the Restoration by Tenant, less all payments heretofore made to Tenant out of the Restoration Funds. Upon completion of and payment for the Restoration by Tenant, the balance of the Restoration Funds shall be paid over to Tenant, subject to the rights of any Leasehold Mortgagee named as an insured. If the estimated cost of any Restoration (i) is equal to or greater than \$5,000,000.00 (as adjusted on each anniversary of the Lease Commencement Date for any increases in CPI during the prior year), and (ii) exceeds the insurance proceeds received by Depository, then, prior to the commencement of such Restoration or thereafter if at any time it is determined by Landlord that the cost to complete the Restoration exceeds the unapplied portion of such insurance proceeds, Tenant shall from time to time immediately deposit with Depository a bond, cash, irrevocable letter of credit or other security reasonably satisfactory to Landlord in the amount of such excess, to be held and applied by Depository in accordance with the provisions of this Section, as security for the completion of the work, free of public improvement, vendors', mechanics', laborers' or materialmen's statutory or other similar liens; provided, however, that if at any time, or from time to time, such security exceeds the maximum estimated outstanding costs of Restoration, as determined by Tenant's Architect and as reasonably approved by Landlord, then Tenant shall be entitled to a return of the excess security promptly thereafter (which may entail Tenant delivering a substitute letter of credit in the amount then required hereunder). If Landlord makes the Restoration at Tenant's expense, as provided in Section 10.2, then, as provided above with respect to Tenant, Depository shall pay over the Restoration Funds to Landlord, from time to time, upon Landlord's application accompanied by a certificate containing the statements required under clauses (A) and (B) of Section 10.4(a)(i), to the extent not previously paid to Tenant pursuant to this Section 10.3, and Tenant shall pay to Depository, on demand, any sums which Landlord certifies to be an estimate of the amount necessary to complete the Restoration, less the undisbursed Restoration Funds. For the purposes of this Section 10.3, insurance proceeds for an otherwise insured casualty loss shall include the amount of any applicable deductible, which shall be paid by Tenant.

**10.4 Conditions to Payment.** The following shall be conditions to each payment made to Tenant as provided in Section 10.3 above:

- (a) there shall be submitted to the Depository and Landlord (i) a certificate of the engineer or architect referred to in Section 10.3 stating (A) that the sum then requested to be withdrawn either has been paid by Tenant or is justly due to contractors, subcontractors, materialmen, engineers, architects or other persons (whose names and addresses shall be stated) who have rendered or furnished work, labor, services, materials, fixtures or equipment for the work and giving a brief description of such work, labor, services, materials, fixtures or equipment and the principal subdivisions or categories thereof and the several amounts so paid or due to each of such Persons in respect thereof, and stating in reasonable detail the progress of the Restoration up to the date of such certificate; and (B) that no part of such expenditures has been or is being made the basis, in any previous or then pending request, for the withdrawal of insurance money or has been made out of the proceeds of insurance received by Tenant; and (ii) appropriate sworn statements and lien waivers (which comply with the mechanics' lien laws of the State of Tennessee from all persons receiving payment under such draw;



(b) there shall be furnished to the Depository a title search showing that there are no vendors', mechanics', laborers' or materialmen's or other liens affecting the Premises or any part thereof in connection with work done, authorized or incurred at or relating to the Premises which have not been discharged of record; and

(c) at the time of making such payment, there is no Event of Default on the part of Tenant under this Lease.

10.5 **Inconsistency with Financing Documents.** Notwithstanding anything to the contrary in this Article 10, in the event of a conflict between (x) the provisions of this Article 10 specifying the procedure whereby Restoration Funds payable to Tenant hereunder are disbursed to fund the costs of Restoration and (y) any provision of any Leasehold Mortgage (or any of the financing documents evidencing the indebtedness secured thereby) or any financing documents evidencing or securing any Mezzanine Financing specifying a different procedure with regard to disbursement of any Restorations Funds, if written notice of such discrepancy shall have been delivered to Landlord by Tenant or the applicable Permitted Leasehold Mortgagee or Permitted Mezzanine Lender prior to Landlord's obligation to disburse any such Restoration Funds, the applicable provision of such Leasehold Mortgage (or any of the financing documents evidencing the indebtedness secured thereby) or any financing documents evidencing or securing any Mezzanine Financing, as the case may be, shall govern and control.

10.6 **Destruction in the Last Twenty-Four Months.** If, at any time during the last twenty-four (24) months of the Term of this Lease, any material portion (as reasonably determined by Landlord or Tenant) of the Premises are damaged or destroyed by fire, storm, or other casualty, then Tenant may, by written notice to Landlord and with the consent of a Permitted Leasehold Mortgagee, terminate this Lease, in which case neither Party shall have any further liability under this Lease except as otherwise expressly set forth herein. In the event of any termination under this Section 10.6, Tenant must either, at Tenant's election (a) repair or remove any improvements located on the Premises that are damaged by such casualty and pay to Landlord any balance of casualty insurance proceeds that exists after paying all costs of such repair or removal or (b) assign to Landlord any available insurance proceeds not previously applied by Tenant to stabilize the Building.

## ARTICLE 11

### CONDEMNATION

#### 11.1 **Significant Taking.**

(a) If, at any time during the Term, the whole or any Significant Portion (as defined below) of the Premises shall be taken for any public or quasi-public purpose by any lawful power or authority by the exercise of the right of condemnation or eminent domain or by agreement among Landlord (a "Taking"), Tenant and those authorized to exercise such right, this Lease and the Term shall terminate and expire on the date of such taking automatically, in the case of taking of the whole, or at Tenant's option, in any other case, and the Rent payable by Tenant hereunder shall be apportioned as of the date of such taking. If Tenant has and chooses to exercise the option to cancel this Lease provided for herein, it shall notify Landlord within forty-five (45) days after the date that Tenant receives notice of such taking. The cancellation shall be effective as of the Date of Taking.

(b) If the whole or any Significant Portion of the Premises shall be taken or condemned and Tenant elects to cancel this Lease as provided for in Section 11.1(a), then any resulting condemnation award shall be allocated as follows: (i) there shall first be paid such amounts as

shall be necessary to reimburse Landlord and Tenant for their reasonable out-of-pocket costs and expenses incurred in connection with the imposition of such award (including, without limitation, attorneys' fees); and (ii) then, the remainder of such award shall be apportioned between Landlord and Tenant pro rata in the following ratio: (x) to Landlord, the product of (A) a fraction, the numerator of which is the Value of Landlord's Estate and the denominator of which is the sum of the Value of Landlord's Estate and the Value of Tenant's Estate, multiplied by (B) the balance of the award after application of fees and expenses as set forth in clause (i) of this sentence; and (y) to Tenant, the product of (A) a fraction, the numerator of which is the Value of Tenant's Estate and the denominator of which is the sum of the Value of Landlord's Estate and the Value of Tenant's Estate, multiplied by (B) the balance of the award after application of fees and expenses as set forth in clause (i) of this sentence.

(c) For purposes of this Section, the "Date of Taking" shall be deemed to be the earlier of (i) the date on which actual possession of the whole or substantially all of the Premises or a part thereof, as the case may be, is acquired by any lawful power or authority pursuant to the provisions of applicable federal or state law, or (ii) the date on which title to the Premises or the aforesaid portion thereof shall have vested in any lawful power or authority pursuant to the provisions of the applicable federal or state law.

(d) For purposes of this Article, a "Significant Portion" of the Premises shall be deemed to mean such portion of the Premises as, when so taken, (i) would leave remaining a balance of the Premises which, due either to the area so taken or the location of the part so taken in relation to the part not so taken, would not in Tenant's reasonable estimation (using reasonable business judgment, and exercised in good faith and in a non-arbitrary manner), under economic conditions, market conditions, applicable zoning laws or building regulations then existing or prevailing, readily accommodate new improvements (or restored Tenant Improvements) of a nature similar (in architecture, style, floor plans, facade, shape, height, configuration, landscaping and overall aesthetic sense) to the Tenant Improvements existing at the date of such taking and after performance of all covenants, agreements, terms and provisions herein and by law required to be performed and paid by Tenant, or (ii) if Tenant reasonably determines that the remaining portion of the Premises is insufficient for Restoration so as to allow the economic and feasible operation thereof by Tenant.

(e) Notwithstanding anything to the contrary set forth in this Section 11.1, any amount that would otherwise be required to be paid to Tenant pursuant to this Section 11.1 shall be paid to the Permitted Leasehold Mortgagee, if any, then holding a Leasehold Mortgage, if so required under the terms of its Leasehold Mortgage or any of the other financing documents securing the applicable Leasehold Mortgage Debt, and if Landlord has been notified in advance in writing by Tenant or the Permitted Leasehold Mortgagee that amounts to be paid pursuant to this Section 11.1 are to be paid to the Permitted Leasehold Mortgagee.

11.2 **Restoration**. If Tenant elects not to exercise the option to cancel this Lease pursuant to Section 11.1(a) or if less than a Significant Portion of the Premises is so taken, this Lease and the Term shall continue without abatement of the Rent or diminution of any of Tenant's obligations hereunder. Tenant, whether or not the award shall be sufficient for such purpose, shall proceed with due diligence to Restore any remaining part of the Premises not so taken to complete, rentable, self-contained architectural units in as good condition and repair and of at least the same value as prior to the taking. If Tenant elects not to exercise the option to cancel this Lease pursuant to Section 11.1(a) or if less than a Significant Portion of the Premises is so taken, the award or awards for such taking, less the cost of the determination of the amount thereof (including, without limitation, attorneys' fees), shall be paid to the Depository to reimburse Tenant for the cost of Restoration if the cost of Restoration is equal to \$5,000,000.00 (as adjusted on each

anniversary of the Lease Commencement Date for any increases in CPI during the prior year), or more, or to Tenant if such cost is less than \$5,000,000.00 (as adjusted on each anniversary of the Lease Commencement Date for any increases in CPI during the prior year). Subject to the provisions and limitations in this Article, the Depositary shall make available to Tenant as much of that portion of the award actually received and held by the Depositary, if any, less all reasonable expenses paid or incurred by the Depositary and Landlord in the condemnation proceedings, as may be necessary to pay the cost of Restoration of the part of the Tenant Improvements remaining in accordance with Article 10. Such Restoration, the estimated cost thereof, the payments to Tenant on account of the cost thereof, Landlord's right to perform the same and Tenant's obligation with respect to condemnation proceeds held by it, shall be done, determined, made and governed in accordance with and subject to the provisions of Article 10. Payments to Tenant as aforesaid shall be disbursed in the manner set forth in Article 10. Any balance of the award held by the Depositary after completion of the Restoration shall be apportioned between Landlord and Tenant pro rata in the following ratio: (x) to Landlord, the product of (A) a fraction, the numerator of which is the Value of Landlord's Estate and the denominator of which is the sum of the Value of Landlord's Estate and the Value of Tenant's Estate, multiplied by (B) the balance of the award after application of fees and expenses as set forth in clause of this sentence; and (y) to Tenant, the product of (A) a fraction, the numerator of which is the Value of Tenant's Estate and the denominator of which is the sum of the Value of Landlord's Estate and the Value of Tenant's Estate, multiplied by (B) the balance of such award after application of fees and expenses as set forth in clause (i) of this sentence. The proceeds of any security deposited with the Depositary pursuant to Section 11.3 remaining after completion of the Restoration shall be paid to Tenant, subject to the rights of any Leasehold Mortgagees. If the portion of the award made available by the Depositary, as aforesaid, is insufficient for the purpose of paying for the Restoration, Tenant shall nevertheless be required to make the Restoration and pay any additional sums required for the Restoration.

Notwithstanding anything to the contrary in the 11.2, in the event of a conflict between (x) any provision of this Section 11.2 specifying the procedure whereby condemnation proceeds payable to Tenant hereunder are disbursed to fund the costs of Restoration and (y) any provision of any Leasehold Mortgage (or any of the financing documents evidencing the indebtedness secured thereby) or any financing documents evidencing or securing any Mezzanine Financing specifying a different procedure with regard to disbursement of any condemnation proceeds, if written notice of any such discrepancy shall have been delivered to Landlord by Tenant or the applicable Permitted Leasehold Mortgagee or Permitted Mezzanine Lender prior to Landlord's obligation to disburse any such condemnation proceeds, the applicable provision of such Leasehold Mortgage (or any of the financing documents evidencing the indebtedness secured thereby) or any financing documents evidencing or securing any Mezzanine Financing, as the case may be, shall govern and control.

11.3 **Excess Cost**. If the estimated cost of any Restoration required by the terms of this Article (i) is equal to or greater than \$5,000,000.00 (as adjusted on each anniversary of the Lease Commencement Date for any increases in CPI during the prior year), and (ii) exceeds the net condemnation award received by the Depositary, as determined in the manner set forth in Section 11.2, then, prior to the commencement of such Restoration or thereafter if it is determined by Landlord that the cost to complete the Restoration exceeds the unapplied portion of such award, Tenant shall from time to time immediately deposit with the Depositary a bond, cash, irrevocable letter of credit or other security satisfactory to Landlord in the amount of such excess, to be held and applied by the Depositary in accordance with the provisions of Section 11.2, as security for the completion of the work, free of public improvement, vendors', mechanics', laborers' or materialmen's statutory or other similar liens; provided, however, that if at any time, or from time to time, such form of security exceeds the maximum estimated outstanding costs of Restoration, as determined by Tenant's Architect and as reasonably approved by Landlord, then Tenant shall be entitled to a return of the excess security promptly thereafter (which may entail Tenant providing a substitute letter of credit in the amount then required hereunder).

11.4 **Taking of Fee.** Notwithstanding anything to the contrary contained in this Lease, in case of any taking of the fee interest in the Premises, if after such taking (x) this Lease will remain in effect or (y) after such taking Tenant' rights under this Lease are not materially affected, or any governmental action not resulting in the taking or condemnation of any portion of the Premises but creating a right to compensation, then this Lease shall continue in full force and effect without reduction, diminution or abatement of Rent and the entire award shall be paid to Landlord.

11.5 **Temporary Taking.** If, at any time during the Term, the whole or any part of the Premises shall be taken for any temporary public or quasi-public purpose by any lawful power or authority by the exercise of the right of condemnation or eminent domain, or by agreement among Landlord, Tenant and those authorized to exercise such right, this Lease shall continue in full force and effect without reduction, diminution or abatement of Rent and Tenant shall continue to perform and observe all of its obligations hereunder (including the obligation to pay Rent as provided in this Lease) as though such temporary taking had not occurred except only to the extent that it may be prevented from so doing by the terms of the order of the authority which made the taking or by the conditions resulting from such taking, including the loss of its possession of all or any part of the Premises. If the temporary taking is for a period entirely within the Term of this Lease, then Tenant shall be entitled to receive the entire amount of any award made for such taking, whether paid by way of damages, rent or otherwise. If the period of the temporary taking extends beyond the termination of the Term of this Lease, the amount of such award, after payment to Landlord therefrom of the estimated cost of restoration of the Tenant Improvements, shall be apportioned between Landlord and Tenant as of the date of such termination, Landlord receiving the portion thereof multiplied by a fraction, the numerator of which shall be the number of years (or fractions thereof) in the period of temporary taking extending beyond the termination of the Term of this Lease, and the denominator of which shall be the number of years (or fractions thereof) in the period of the temporary taking, and, subject to the rights of any Leasehold Mortgagees, Tenant shall receive the balance of such award.

11.6 **General Provisions.** Each of the parties shall execute and deliver any and all documents that may be reasonably required in order to facilitate collection by the parties of any and all awards in respect of any taking affecting the Premises in accordance with the provisions of this Article. If there is more than one Leasehold Mortgage, Landlord shall recognize the Leasehold Mortgagee whose Leasehold Mortgage is senior in lien as the Leasehold Mortgagee having priority as to the rights of a Leasehold Mortgagee under this Article unless otherwise instructed by the Leasehold Mortgagee. Both Landlord and Tenant must consent to, enter into, settle or compromise any taking or other governmental action creating a right to compensation in Tenant as provided in this Article, which consent shall not be unreasonably withheld, conditioned or delayed.

## ARTICLE 12

### ASSIGNMENT AND TRANSFERS

12.1 **Assignment and Transfer Generally.** Except as otherwise set forth below in this Article 12, Tenant may not assign this Lease, sublease or otherwise Transfer any portion of the Premises, or cause or permit a Transfer of any direct or indirect ownership interest in Tenant without the prior written consent of Landlord in accordance with the provisions of this Article 12.

12.2 **Definitions.** The following terms shall be defined as indicated for the purposes of this Article 12:

(a) **Transfers Allowed as of Right.** Notwithstanding the provisions contained in Section 12.1, Tenant shall not be required to obtain the consent of Landlord for any "**Transfers Allowed as of Right**", which shall mean any of the following:

i. any Transfer of any direct or indirect beneficial interest in Tenant between or among two or more of the individuals or entities (A) that own direct or indirect beneficial interests in Tenant as of the Lease Commencement Date or (B) that acquire direct or indirect beneficial interests in Tenant subsequent to the Lease Commencement Date, provided in each case so long as (x) such transfer does not cause a change in Control in Tenant (y) an existing owner of direct interests in Tenant (or if prior to the expiration of the Transfer Restriction Period, Fallon) retains an ownership interest in Tenant and (z) prior to the expiration of the Transfer Restriction Period, Guarantor retains a direct or indirect equity interest in Tenant;

ii. any change in Control or the ownership of Tenant solely as between Tenant's then direct or indirect equity investor(s) as a result of the exercise by such equity investor(s) of any rights of such investor(s) under Tenant's or its direct or indirect owner's organizational documents, provided that after giving effect to such change, (i) Tenant continues to be Controlled by and owned by one or more of the investor(s) that owned direct or indirect equity interests in Tenant immediately prior to such change taking effect, and (ii) prior to the expiration of the Transfer Restriction Period, Guarantor retains a direct or indirect equity interest in Tenant;

iii. the granting of a Leasehold Mortgage with respect to Tenant's interest in this Lease or the Premises, together with, if applicable, any Equity Pledge, to the extent permitted by this Lease, provided that such grant is not made pursuant to a plan designed with the purpose of circumventing any applicable restrictions on Transfers set forth in this Article 12;

iv. the foreclosure of any Leasehold Mortgage (including, any assignment of this Lease in connection therewith) or any Equity Pledge (including any Transfer occurring as part of any such foreclosure of any Leasehold Mortgage or Equity Pledge), or the granting of a deed or assignment in lieu of such foreclosure or other similar Transfer pursuant to a Leasehold Mortgage or Equity Pledge, in each case to the extent the underlying Leasehold Mortgage or Equity Pledge was entered into in accordance with the terms of this Lease;

v. where the Leasehold Mortgagee or an Affiliate thereof is the party that purchases at foreclosure, the grantee or assignee under a deed or assignment in lieu of foreclosure or the party that otherwise acquires this Lease or the leasehold estate in the Premises hereunder in connection with the enforcement of its Leasehold Mortgage, or, if applicable, that acquire direct or indirect interests in Tenant in connection with the enforcement of its Equity Pledge, any Transfer by such Leasehold Mortgagee or its Affiliate, including, without limitation, (x) a Transfer by such Leasehold Mortgagee or its Affiliate to another Affiliate of such Leasehold Mortgagee, or (y) a Transfer by such Leasehold Mortgagee or its affiliate to an unrelated third party, so long as such transferee is not a Prohibited Person (defined below);

vi. the foreclosure of any pledge of the direct or indirect interests in Tenant provided as collateral for any Mezzanine Financing or for any indebtedness secured by a Leasehold Mortgage, or the granting of an assignment in lieu of such foreclosure or other similar Transfer pursuant to a Mezzanine Financing or any Equity Pledge entered into in accordance with this Lease (any of the foregoing, and any of the transfers described in Section 12.2(a) (iv) and (v) above, a "**Foreclosure Sale**");

vii. the granting of an Equity Pledge for any indebtedness secured by a Leasehold Mortgage or for any Mezzanine Financing to the extent permitted by this Lease, provided that such granting of a pledge is not pursuant to a plan designed with the purpose of circumventing any applicable restrictions on Transfers set forth in this Article 12;

viii. where the Mezzanine Lender or an Affiliate thereof is the party that purchases at foreclosure, the grantee or assignee under an assignment in lieu of foreclosure or the party that otherwise acquires the direct or indirect interests of Tenant in connection with an enforcement of its Mezzanine Financing, any Transfer by such Mezzanine Lender or its Affiliate, including, without limitation, (x) a Transfer by such Mezzanine Lender or its Affiliate to another Affiliate of such Mezzanine Lender, or (y) a Transfer by such Mezzanine Lender or its affiliate to an unrelated third party, so long as such transferee is not a Prohibited Person (defined below);

ix. Transfers of stock or other ownership interests by or in a Person which is listed (or in connection with such Transfer becomes listed) on a recognized public securities exchange;

x. the granting, making, or entering into of an Occupancy Sublease with an Occupancy Subtenant in accordance with Article 14;

xi. the assignment, sub-sublease, or similar transfer by an Occupancy Subtenant of rights of space under its Occupancy Sublease subject to the terms and conditions of this Lease;

xii. any direct or indirect Transfer of Tenant's leasehold interest under this Lease to an Affiliate of Tenant, or any Transfer by the holder of a direct or indirect beneficial interest in Tenant to an Affiliate of such holder, so long as (A) any such Affiliate continues to use, rent, and operate the Premises substantially in accordance with this Lease, (B) such Affiliate has financial ability at least equal to that of Tenant, and Tenant provides evidence reasonably satisfactory to Landlord that the proposed assignee is in fact an Affiliate of Tenant that possesses such financial ability and experience (which financial capacity shall be evidenced by such Affiliate's ability to acquire Tenant's leasehold interest in the Premises at its fair market value as reasonably determined by Tenant or, if such transfer is without consideration, such other evidence as is reasonably required by Landlord, provided that any evidence accepted by a Permitted Leasehold Mortgagee or Permitted Mezzanine Lender shall be deemed sufficient evidence of such transferee's financial ability to perform under this Lease), and (C) prior to the expiration of the Transfer Restriction Period, Guarantor retains a direct or indirect equity interest in Tenant;

xiii. (A) any other exercise by a Leasehold Mortgagee or a Mezzanine Lender of rights or remedies under the documents governing any indebtedness secured by the Leasehold Mortgage or any Mezzanine Financing permitted by this Lease (as applicable) or under applicable law, as a result of which such Leasehold Mortgagee or Mezzanine Lender (or their respective designee or nominee) succeeds to the rights of Tenant under this Lease or (B) any other event in which any Leasehold Mortgagee or Mezzanine Lender (or their respective designee or nominee) shall succeed to the rights of Tenant under this Lease; and/or

xiv. any Transfer by the holder of a direct or indirect beneficial interest in Tenant to trusts or other estate planning vehicles or for other estate planning purposes, including Transfers to spouses, heirs, descendants, legatees or devisees, as well as any comparable Transfers resulting from a will or pursuant to the laws of intestate succession or judicial decree.

Notwithstanding anything in the foregoing to the contrary, Guarantor shall remain liable under its Guaranty following any Transfers Allowed By Right, to the extent set forth in the Guaranty.

(b) Transfer Restriction Period. “**Transfer Restriction Period**” shall mean the period beginning on the Lease Commencement Date and ending upon Substantial Completion of the Project.

(c) Prohibited Person. “**Prohibited Person**” shall mean:

i. any Person (or any Person whose operations are directed or controlled by a Person) that is known to Tenant (upon commercially reasonable inquiry) to (a) have been convicted or has pleaded guilty in a criminal proceeding to a felony or any crime involving moral turpitude, (b) be an organized crime figure, (c) be reputed to have substantial business or other affiliations with an organized crime figure, and (d) be an on-going target of a grand jury investigations convened pursuant to applicable statutes concerning organized crime;

ii. any Person listed in the Annex to, or otherwise subject to the provisions of, the Executive Order No. 13224 on Terrorist Financing, effective September 24, 2001, and relating to Blocking Property and Prohibiting Transactions With Persons Who Commit, Threaten to Commit, or Support Terrorism (the “**Executive Order**”);

iii. any Person that is owned or controlled by, or acting for or on behalf of, any person or entity that is listed to the Annex to, or is otherwise subject to the provisions of, the Executive Order;

iv. any Person who has been identified by any United States governmental authority having jurisdiction with respect to such matters as a Person who commits, threatens or conspires to commit or supports “terrorism” as defined in the Executive Order;

v. any Person that is named as a “specially designated national and blocked person” on the most current list published by the U.S. Treasury Department Office of Foreign Assets Control at its official website, [www.treasury.gov/ofac/downloads/sdnlist.pdf](http://www.treasury.gov/ofac/downloads/sdnlist.pdf), or at any replacement website or other replacement official publication of such list;

vi. any country, or any Person that, directly or indirectly, is controlled (rather than only regulated) by a government, the effects of the activities of which are regulated or controlled pursuant to regulations of the United States Treasury Department or executive orders of the President of the United States of America issued pursuant to the following: (a) the Trading with the Enemy Act of 1917, as amended, (b) the International Emergency Economic Powers Act of 1976, as amended, and (c) the Anti-Terrorism and Arms Export Amendments Act of 1989, codified at Section 6(j) of the Export Administration Act of 1979, as amended;

vii. any Person that controls, is controlled by, or is under common control with (including any indirect partners, members, principals or controlling equity investors thereof) any nation, organization or group adjudicated in violation, or under indictment for violation, of or under any applicable anti-money laundering and antiterrorist laws, regulations, rules, executive orders and government guidance (including, without limitation, USA PATRIOT Act, and other authorizing statutes, executive orders and regulations administered by the Office of Foreign Assets Control of the U.S. Department of Treasury), and other agency rules and regulations;

viii. any Person that is in pending litigation with Metro (or litigation threatened in writing against Metro), provided that (A) tax appeals and other disputes regarding administrative governmental functions shall not be considered litigation for purposes of this provision and (B) (i) Landlord shall deliver written notice of any such pending or threatened litigation within two (2) Business Days of Tenant providing Landlord with notice of the identity of any such Person and (ii) Tenant shall be entitled to rely on such notice or lack thereof for a period of up to ninety (90) days after Tenant’s receipt of the same;

ix. to the extent that this Lease constitutes a contract to acquire or dispose of services, supplies, information technology, or construction for the purposes of Tennessee Code Annotated Section 12-4-119 (as the same may be amended, supplemented, or replaced from time to time), any Person engaged in a “Boycott of Israel” (as that phrase is defined in such Section); or

x. any “sanctioned nonresident alien,” “sanctioned foreign business,” or “sanctioned foreign government” as those phrases are defined in Tennessee Code Annotated Section 66-2-301 (as the same may be amended, supplemented, or replaced from time to time).

12.3 **Transfers Allowed as of Right.** Transfers Allowed as of Right shall be permitted both during and after the Transfer Restriction Period, and shall not require Landlord’s consent; provided, however, that if Tenant is required under any applicable financing documents to provide written notice to the applicable Leasehold Mortgagee or Mezzanine Lender of any Transfer Allowed as of Right, then Tenant shall also provide written notice to Landlord within thirty (30) days after such Transfer.

12.4 **Transfers During Transfer Restriction Period.** During the Transfer Restriction Period, Tenant shall not Transfer its interest in this Lease or permit any Transfer of any direct or indirect interest in Tenant without the prior written consent of Landlord in its sole discretion, except, in each case, for Transfers Allowed as of Right

12.5 **Transfers After Transfer Restriction Period.** After the Transfer Restriction Period expires, except for Transfers Allowed as of Right, Tenant shall not Transfer its interest in this Lease or permit any Transfer of any direct or indirect interest in Tenant without the prior written consent of Landlord, provided that, Landlord’s consent shall not be required for any Transfer to a transferee meeting the requirements set forth in Section 12.6(A)-(D) below; provided, however that Tenant shall deliver to Landlord, at least ten (10) days prior to the consummation of any such transfer, written notice of any such transfer, together with a certification from Tenant that such transferee meets the applicable requirements set forth in Section 12.6(A)-(D), which certification must include reasonably sufficient detail as to such transferee’s satisfaction of the applicable requirements set forth in Section 12.6(A)-(D).

12.6 **Additional Requirements for Transfers.** With respect to any Transfer of Tenant’s interest in the Lease or of a direct or indirect interest in Tenant that requires Landlord’s consent as set forth above, (A) the proposed transferee shall, in the case of a direct Transfer of Tenant’s interest in the Lease, be qualified to do business in the State of Tennessee; (B) neither the transferee nor any Person that directly or indirectly Controls the transferee shall be a Prohibited Person (provided that a Person described in clause (viii) of Section 12.2(c) shall not constitute a Prohibited Person for any Transfer other than a direct transfer of Tenant’s interest in the Lease); (C) the transferee (or the managing agent engaged to manage the Premises on behalf of the transferee) shall have experience in the ownership, operation, and/or management of similar real estate (or will hire a property manager with such experience); (D) the transferee has financial ability to perform the obligations of Tenant under the Lease, and Tenant provides evidence reasonably satisfactory to Landlord that the proposed transferee possesses such financial ability (which financial capacity shall be evidenced by such transferee’s ability to acquire Tenant’s leasehold interest in the Premises or a direct or indirect interest in Tenant (as the case may be) at its fair market value as reasonably determined by Tenant or, if such transfer is without consideration, such other evidence as is reasonably required by Landlord, provided that any evidence accepted by a Permitted Leasehold Mortgagee or Permitted Mezzanine Lender shall be deemed sufficient evidence of such transferee’s financial ability to perform under this Lease); and (E) in the case of a Transfer of Tenant’s direct interest in the Lease, the transferee assumes, by written instrument reasonably satisfactory to Landlord, the obligations on the part of Tenant to be performed and observed under this Lease, in each case, to the extent accruing from and after the date of such Transfer. Tenant shall pay all reasonable out-of-pocket expenses incurred by Landlord, including, without limitation,



reasonable attorneys' fees incurred by Landlord, in connection with the preparation and review of any such written instruments in connection with a proposed Transfer, whether or not such transaction closes.

12.7 **Tenant's Liability.** In the event of a transfer of Tenant's entire leasehold interest hereunder in accordance with the terms hereof, the transferor shall be relieved from liability for Tenant's obligations under this Lease arising and accruing after such assignment and the transferee shall be responsible for all obligations under this Lease arising and accruing from and after such assignment.

12.8 **Additional Encumbrances.** Notwithstanding any provisions in this Lease to the contrary, Tenant shall have the right to grant easements and other agreements as may be reasonably necessary or appropriate in further of the construction, use, and occupancy of the Project as contemplated herein. Landlord covenants to join in (and, to the extent applicable, cause any of its Affiliates that own land within the Campus or adjacent thereto that would be affected thereby to join in), if required, and execute and deliver such easement and other agreements in form and substance reasonably satisfactory to Landlord.

12.9 **Miscellaneous.** Tenant agrees that ownership of Tenant's estate under this Lease and all of Tenant's rights, title, and interest in and to the Tenant Improvements shall not be separable, and that, except as allowed by Article 13 and Article 14 with respect to Leasehold Mortgages and Occupancy Subleases, any attempt to transfer any of Tenant's right, title, or interest in the Tenant Improvements shall be null and void and a breach of this Lease, unless accompanied by a transfer and assignment of Tenant's estate under this Lease. Reference herein to Transfer of Tenant's interest in this Lease or Tenant's leasehold estate hereunder shall mean a sale, assignment, or other disposition of the entire interest of Tenant in the Premises. The foregoing shall not, however, prevent sales or other Transfers of partial ownership interest in Tenant which are otherwise in compliance with the provisions of this Article 12. Any Transfer which is not permitted hereby, and which is made without Landlord's consent shall be void and of no force or effect.

## ARTICLE 13

### **LEASEHOLD MORTGAGES**

#### 13.1 **Right to Mortgage and Obtain Mezzanine Financing.**

(a) Provided that there is no Event of Default by Tenant that then exists, and subject to the provisions of this Article 13, Tenant (and any entity which owns (directly or indirectly) an ownership interest in Tenant) shall at all times and from time to time have the right to encumber, pledge or convey all, but not less than all, of its leasehold estate in the Premises or its title to and interest in the Tenant Improvements by way of a bona fide Leasehold Mortgage and/or Mezzanine Financing Security to secure the payment of any loan or loans obtained by Tenant or any entity which owns (directly or indirectly) an ownership interest in Tenant; provided, however, that Tenant shall give contemporaneous written notice to Landlord of any intent to exercise such rights hereunder, including in such notice the names and addresses of such Leasehold Mortgagee or Mezzanine Lender.

(b) For purposes of this Article 13, the term "Total Project Costs" shall mean the total amount of costs for the Project as set forth in the Approved Project Budget.

13.2 **Leasehold Mortgage and Mezzanine Financing Security Not Requiring Landlord's Consent.** Tenant may, without having to obtain Landlord's consent, but with prior notice to Landlord, grant a Leasehold Mortgage or Mezzanine Financing Security, as applicable, which secures financing for an amount (when aggregated with all other outstanding Leasehold Mortgages or Mezzanine Financings) that is (i) with respect to any construction financing, up to eighty percent (80%) of the Total Project Costs or

(ii) with respect to any other financing, up to seventy percent (70%) of the then fair market value of Tenant's leasehold interest in the Premises (including all Tenant Improvements thereon), with fair market value in all instances to be determined by an independent appraiser selected by the Leasehold Mortgagee or Mezzanine Lender, as applicable; provided, that, with respect to any such financing, Tenant certifies to Landlord that such financing complies with either clause (i) or clause (ii) above, as applicable.

13.3 **Leasehold Mortgage and Mezzanine Financing Security Requiring Consent.** Any proposed Leasehold Mortgage or Mezzanine Financing Security which does not meet one of the two sets of alternate requirements under Section 13.2 above shall require Landlord's consent, which consent shall not be unreasonably withheld, delayed or conditioned. Tenant shall reimburse Landlord for all costs and expenses actually incurred by Landlord incident to responding to any approval requested for any such Leasehold Mortgage financing or Mezzanine Financing, including the fees and expenses of any appraiser or expert hired by Landlord with respect thereto. Such fees and expenses shall be reimbursed to Landlord within thirty (30) days of an invoice therefor, whether or not Landlord shall approve any proposed financing, and any amount not paid to Landlord within such thirty (30) days will accrue interest at the Default Rate.

13.4 **General Limitations on Leasehold Mortgages and Mezzanine Financings.** Any Leasehold Mortgagee or Mezzanine Lender must be an Institutional Lender. The rights provided in Section 13.6 shall only be available to a Leasehold Mortgagee or Mezzanine Lender which becomes a Permitted Leasehold Mortgagee or Permitted Mezzanine Lender pursuant to Section 13.5. No Leasehold Mortgage or Mezzanine Financing Security or any extension, modification or amendment thereof shall be a lien or encumbrance upon the estate or interest of Landlord in and to the Premises or any part thereof. Tenant shall use commercially reasonable efforts to cause each Leasehold Mortgagee and Mezzanine Lender to agree in writing to provide Landlord with written notice of any defaults by Tenant under a Leasehold Mortgage or Mezzanine Financing Security (as applicable) simultaneously with providing notice of the same to Tenant.

13.5 **Permitted Leasehold Mortgagee and Permitted Mezzanine Lender.** If a Leasehold Mortgagee or Mezzanine Lender shall, by written notice to Landlord given within thirty (30) days of the execution, delivery and the recording of a Leasehold Mortgage or Mezzanine Financing Security, as applicable, notify Landlord thereof of the name and address of the Leasehold Mortgagee or Mezzanine Lender for notice purposes, and of the recording reference of its Leasehold Mortgage or Mezzanine Finance Security, as applicable, and with such notice shall furnish to Landlord a true copy of such Leasehold Mortgage or Mezzanine Finance Security, Landlord shall, promptly upon receipt of a communication purporting to constitute the notice provided for in the foregoing provisions of this Section 13.5, either provide the Leasehold Mortgagee or Mezzanine Lender submitting such communication with a written confirmation of the receipt of such communication and that the same constitutes the notice provided for in the foregoing provisions of this Section 13.5, or notify Tenant and such Leasehold Mortgagee or Mezzanine Lender in writing of the rejection of such communication as not conforming with the foregoing provisions of this Section 13.5 and specifying the basis for such rejection. In the latter case, Landlord shall promptly issue such written confirmation of receipt and conforming notice if the Leasehold Mortgagee or Mezzanine Lender subsequently gives Landlord another written notice correcting Landlord's objections to the prior notice. Without relieving Landlord of the requirement of giving the aforesaid written confirmation, Landlord shall be deemed to have confirmed if it does not respond to Tenant and the Leasehold Mortgagee or Mezzanine Lender in writing as aforesaid within thirty (30) days after receipt of Leasehold Mortgagee's or Mezzanine Lender's notice or amended notice. Each Leasehold Mortgagee or Mezzanine Lender that is an Institutional Lender and notifies Landlord in conformity with the foregoing provisions of this Section 13.5 shall be deemed a "Permitted Leasehold Mortgagee" or a "Permitted Mezzanine Lender", as applicable. In the event of any assignment of a Leasehold Mortgage or Mezzanine Financing Security or in the event of a change of address for notice purposes of a Permitted Leasehold Mortgagee or Permitted Mezzanine Lender or of an assignee of any such Leasehold Mortgagee or Mezzanine Lender, notice of the

new name and address for notice purposes shall be provided to Landlord as a condition to the continued availability of the rights hereunder of a Permitted Leasehold Mortgagee or Permitted Mezzanine Lender, as applicable.

**13.6 Rights of Permitted Leasehold Mortgagees and Permitted Mezzanine Lenders.**

Provided that Tenant's Leasehold Mortgage or Mezzanine Financing Security remains unsatisfied or until written notice of satisfaction is given to Landlord by the subject Permitted Leasehold Mortgagee or Permitted Mezzanine Lender, any Permitted Leasehold Mortgagee or Permitted Mezzanine Lender shall have the following rights and privileges and the following provisions shall apply thereto:

(a) Notice of Tenant Defaults. Landlord shall, upon giving Tenant any notice of default or any notice of the intention to exercise a remedy, simultaneously give a copy of such notice to each Permitted Leasehold Mortgagee and Permitted Mezzanine Lender. Wherever in this Lease notice is to be given to a Permitted Leasehold Mortgagee or Permitted Mezzanine Lender at its address specified in accordance with the provisions of Section 13.5 and otherwise complying with the terms of the notice provisions of this Lease, such notice shall conclusively be treated as having been "given" within the meaning of the respective provisions calling for notice to a Permitted Leasehold Mortgagee or Permitted Mezzanine Lender.

(b) Right to Cure Tenant Defaults. Each Permitted Leasehold Mortgagee and Permitted Mezzanine Lender shall have the same period, after such notice has been given to it, for remedying any default or causing the same to be remedied, as is given Tenant after the giving of such notice to Tenant, plus (x) an additional period of twenty (20), in the case of a monetary default, or (y) an additional period of sixty (60) days, in the case of a non-monetary default, and if such default cannot with due diligence be cured within such additional period, an additional time thereafter not to exceed ninety (90) days in the aggregate (except at otherwise set forth in paragraph (c) below), provided that such cure is initiated during such additional period and, thereafter, the curing of the same is prosecuted with diligence. Landlord shall (i) forbear from taking any action to terminate this Lease on account of such default until any Permitted Leasehold Mortgagee or Permitted Mezzanine Lender, as applicable, has had the aforesaid opportunity to cure the subject default, (ii) accept cure by such Permitted Leasehold Mortgagee or Permitted Mezzanine Lender as a cure by Tenant, and (iii) not terminate this Lease if such Permitted Leasehold Mortgagee or Permitted Mezzanine Lender in fact effects such cure within the applicable aforesaid period.

(c) Defaults Requiring Possession or Foreclosure to Cure. In the event of a default by Tenant which is not reasonably susceptible of being cured by a Permitted Leasehold Mortgagee or Permitted Mezzanine Lender without taking possession of the Premises, foreclosing its Leasehold Mortgage (or its Equity Pledge) or Mezzanine Financing Security or otherwise acquiring Tenant's leasehold interest in the Premises, Landlord shall not terminate this Lease on account of such default if such Permitted Leasehold Mortgagee or Permitted Mezzanine Lender, as applicable, (i) gives notice to Landlord within twenty (20) days after Landlord's notice of default to the Permitted Leasehold Mortgagee or Permitted Mezzanine Lender that such Permitted Leasehold Mortgagee or Permitted Mezzanine Lender intends to take possession, foreclose or otherwise acquire Tenant's leasehold interest, and to cure such default, (ii) commences action to take possession, foreclose or otherwise acquire Tenant's leasehold interest within sixty (60) days after such notice of intention, (iii) thereafter diligently prosecutes such action to completion, (iv) once having obtained possession, foreclosed or otherwise acquired Tenant's leasehold interest, promptly commences to cure the subject default and thereafter diligently prosecutes such cure to completion (or the party purchasing at foreclosure from or acquiring Tenant's leasehold interest by, through or under such Permitted Leasehold Mortgagee

or Permitted Mezzanine Lender, if different from such Permitted Leasehold Mortgagee or Permitted Mezzanine Lender, does so, other than Tenant or any Tenant Affiliate), and (v) during Landlord's period of forbearance pays or causes to be paid all Rent and other monetary obligations of Tenant under this Lease. For the avoidance of doubt, if there is a foreclosure of any Leasehold Mortgage, Equity Pledge or Mezzanine Financing Security (or assignment-in-lieu thereof) prior to Final Completion of the Project, the foreclosing/acquiring Permitted Leasehold Mortgagee or Permitted Mezzanine Lender, as applicable (or the party purchasing at a foreclosure from, or acquiring Tenant's leasehold interest by or, through or under such Permitted Leasehold Mortgagee or Permitted Mezzanine Lender, if the foreclosing or acquiring party is not such Permitted Leasehold Mortgagee or Permitted Mezzanine Lender, other than Tenant or any Tenant Affiliate) shall not be subject to or required to comply with the Anticipated Project Schedule so long as such Permitted Leasehold Mortgagee or Permitted Mezzanine Lender, as applicable (or such other party referenced in the immediately preceding parenthetical), commences working toward Final Completion of the Project within thirty (30) days after any such foreclosure (or an assignment-in-lieu thereof), and thereafter diligently pursues Final Completion of the Project. Nothing in this Section affects Landlord's rights under the Guaranty. Notwithstanding anything to the contrary set forth herein, if and to the extent the references to "other than Tenant or any Tenant Affiliate" in the immediately preceding sentence, and in clauses (iv) and (v) above relate to the foreclosure of any Equity Pledge or Mezzanine Financing Security (or an assignment of all or substantially all of the direct or indirect equity interests in Tenant in lieu of any such foreclosure), such references are intended to refer solely to the former holder(s) of such equity interests and Affiliates of such former holder(s).

(d) Right of Permitted Leasehold Mortgagee to New Lease. In the event of either (i) a termination of this Lease for any reason other than by expiration of the Term or (ii) a rejection of this Lease in any proceeding under the United States bankruptcy code or any other applicable bankruptcy or insolvency laws, the Permitted Leasehold Mortgagee holding the most senior Leasehold Mortgage which elects to do so shall have the right, in addition to the foregoing rights, to elect to have a new lease of the Premises, exercisable by notice in writing to Landlord within sixty (60) days after the giving of notice by Landlord to such Permitted Leasehold Mortgagee of such termination or rejection, for the balance of the Term hereof effective as of the date of such termination or rejection, at the Rent and upon all of the other terms, provisions, covenants and agreements set forth in this Lease, including any consents or approvals of Landlord given to Tenant pursuant to the Lease (including, without limitation, all of the provisions set forth in this Article 13), except that Landlord shall not be required to warrant and defend the right of possession of Tenant under such new lease against Tenant herein or anyone claiming by, through or under Tenant; provided that, concurrently with the execution and delivery of such new lease, such Permitted Leasehold Mortgagee shall have, with respect to monetary defaults, performed or shall perform (or, with respect to non-monetary defaults, diligently pursued the performance (subject to the terms of Sections 13.6(b) and (c)) all obligations of Tenant hereunder reasonably capable of being performed by such Permitted Leasehold Mortgagee which would have accrued hereunder had this Lease remained in force until the time of such execution and delivery. The payment of Rent or any other monies due hereunder and completion of the Tenant Improvements shall always be considered reasonably capable of being performed. Landlord and the subject Permitted Leasehold Mortgagee shall act promptly after such notice and performance to execute and deliver such new lease. Any such new lease shall take into account, and shall not charge the new tenant thereunder for, any Rent that has been paid under this Lease as of the effective date of such new lease. Any such new lease shall provide that, to the extent that the original tenant named under the new lease (or any transferee that is an Affiliate of such original tenant) does not have the experience in the operation and management of first-class multi-property real estate sufficient to perform the tenant's obligations under the new lease, such tenant (or such

transferee) will be obligated to engage a managing agent that has such experience to manage the Premises on behalf of such tenant from and after the Substantial Completion Date; provided, however, that the engagement of any such managing agent shall be subject to Landlord's prior written approval, which approval shall not be unreasonably withheld, delayed or conditioned. Any such new lease shall be superior and not subordinate to any mortgage upon Landlord's fee interest in the Premises hereafter given; and any such new lease may, at the option of such Permitted Leasehold Mortgagee, name as Tenant a nominee of such Permitted Leasehold Mortgagee, other than Tenant or any Tenant Affiliate. Any such new lease shall provide that if, as of the execution of any new lease in accordance with the terms of this Section 13.6(d), Tenant refuses to surrender possession of the Property, then, at the request of the tenant under the new lease and at its sole cost and expense, Landlord shall (1) cooperate as is reasonably necessary with any legal action brought by such tenant to cause Tenant to vacate the Premises (at no out-of-pocket expense to Landlord) and/or (2) solely if required under applicable Legal Requirements, join in any such proceeding or institute such a proceeding. Notwithstanding anything to the contrary set forth herein, if and to the extent it relates to the foreclosure of any Equity Pledge or Mezzanine Financing Security or an assignment of all or substantially all of the direct or indirect equity interests in Tenant in lieu of any such foreclosure, the reference in this Section 13.6(d) to "other than Tenant or any Tenant Affiliate" is intended to refer solely to the former holder(s) of such equity interests and Affiliates of such former holder(s). If as a result of any termination or rejection of the Lease described above in clause (i) or clause (ii) Landlord shall have succeeded to the interests of Tenant under any Occupancy Subleases or other subleases of the Premises or any portion thereof, Landlord shall execute and deliver an assignment of all such interests to the named Tenant under the new lease simultaneously with the delivery of such new lease. Landlord agrees to execute and deliver to the subject Permitted Leasehold Mortgagee a suitable instrument confirming Landlord's obligations under this Section 13.6(d).

(e) Modifications. Landlord shall not unreasonably withhold its consent to any commercially reasonable modification of this Lease reasonably requested by any prospective Leasehold Mortgagee or Mezzanine Lender, provided that Tenant pays Landlord's out-of-pocket third-party costs and expenses in connection with such modifications.

## **ARTICLE 14**

### **SUBLETTING**

14.1 **Right to Sublet.** Except as otherwise set forth in the immediately succeeding sentence of this Section 14.1, Tenant may, as a matter of right and without having to obtain Landlord's consent, but subject to the terms of this Article 14, sublease or license any part or parts of the Premises at any time and from time to time to such Subtenants by subleases upon such terms and conditions as Tenant shall deem fit and proper, provided that such subleases and uses by any Subtenant are subject to the terms of this Lease. Any sublease or license of all or substantially all of the Premises shall require Landlord's prior written consent; provided, however, that Landlord's consent shall not be required for any sublease or license of all or substantially all of the Premises to a transferee meeting the requirements set forth in Section 12.6(A)-(D) so long as Tenant delivers to Landlord, at least ten (10) days prior to the consummation of any such transfer, written notice of any such transfer, together with a certification from Tenant that such transferee meets the applicable requirements set forth in Section 12.6(A)-(D), which certification must include reasonably sufficient detail as to such transferee's satisfaction of the applicable requirements set forth in Section 12.6(A)-(D).

14.2 **Attornment Provisions of Occupancy Sublease.** Each Occupancy Sublease entered into by Tenant with respect to the Premises shall provide that it is subject to and subordinate to this Lease and, subject to the terms of any applicable SNDA, shall provide that, upon termination of the term of this Lease, at Landlord's option, the Subtenant thereunder will attorn to or enter into a new sublease (on identical terms as its then-existing sublease) with Landlord or Landlord's designee. [Within thirty (30) days after request from Landlord, Tenant shall notify Landlord of each sublease entered into by Tenant with respect to the Premises that is then in effect. Such notice shall set forth, with respect to each such sublease, the name of the subtenant, the date of such sublease and the space covered thereby.][*NTD: N/A for residential ground subleases*]

14.3 **Occupancy Subtenants.** Any Subtenant (a) the term of whose sublease (including any extension options) does not extend beyond the Lease Expiration Date, and (b) whose sublease contains the attornment provisions set forth in Section 14.2 (or is subject to an SNDA), shall be deemed an "**Occupancy Subtenant**" and such sublease shall be deemed an "**Occupancy Sublease**".

14.5 **Rights of Occupancy Subtenants.** In the event that this Lease should terminate, be terminated or expire, so that Landlord shall succeed to Tenant's interest and position as sublandlord under any Occupancy Subleases, Landlord shall recognize and give effect to the Occupancy Sublease, which contains the provisions set forth in Section 14.2, of any Occupancy Subtenant and shall not disturb such Occupancy Subtenant's possession thereunder except in accordance with the terms of such Occupancy Sublease (as in a case of a default by such Occupancy Subtenant). The foregoing provisions shall be automatic and not require any further instrument or document to be effective, but within thirty (30) days after the request of Tenant or any Occupancy Subtenant, Landlord shall enter into a subordination, nondisturbance and attornment agreement (a "**Subordination, Nondisturbance and Attornment Agreement**" or "**SNDA**") with such Occupancy Subtenant confirming that it is indeed such a subtenant and has the foregoing rights and, if requested by such Occupancy Subtenant, including such other customary SNDA provisions as shall be reasonably agreed upon by such Occupancy Subtenant and Landlord.

14.6 **Termination of Subleases Other Than Occupancy Subleases.** Tenant covenants and agrees that, in the event of the early termination of this Lease prior to the expiration of the Term of this Lease, Landlord shall have the option to terminate or cancel the sublease of any Subtenant that is not an Occupancy Subtenant.

14.7 **Delivery of Rent Rolls.** Commencing upon the date that Tenant enters into the first [retail/office] Occupancy Sublease for any portion of the Premises, Tenant shall deliver to Landlord a current Rent Roll within thirty (30) days following the end of each calendar year, provided, however, that

Tenant shall deliver additional Rent Rolls from time to time upon Landlord's written request, but in no event more frequently than once per calendar quarter.

## ARTICLE 15

### FORCE MAJEURE

15.1 **Force Majeure.** Except as may be expressly set forth in this Lease, in case there is a delay in or a failure in performance by Landlord or Tenant in the performance of its obligations in making any repairs, alterations or improvements (including any delay on Tenant's part in performing its construction obligations under Article 4), or performing any other covenant or duty to be performed on Landlord's or Tenant's part set forth in this Lease, such delay or failure in performance shall not constitute a default under this Lease to the extent such delay or failure of performance results from a Force Majeure Event (as defined below). As used herein, "**Force Majeure Event**" means acts of God (including, without limitation, weather delays, floods, earthquakes, tornados, fires, mechanical failure of equipment, disease, and the like); war, riot, terrorism, sabotage, acts of a public enemy, moratorium or hostile government action; actual or threatened health emergencies (including, without limitation, epidemic, pandemic, quarantine, or other restrictions related thereto), any work stoppage, or work slowdown (including any failure of building inspectors to reasonably process approvals that cause work stoppage); unusual delays or shortages encountered in transportation, fuel, material, or labor supplies affecting the Nashville, Tennessee metropolitan area generally; any failure of or delay in the availability of any public utility; unforeseeable material shortages, governmental embargo restrictions; injunctions; failure of or delay in any inspection by any Governmental Authority, the failure of any Governmental Authority to timely act on or respond to a request or regulations or any delay caused by any Approval being subject to an appeal proceeding (or, in the event of a successful appeal, any delay required for re-permitting the Project in accordance with such successful appeal); any labor disputes (such as any strike or lockout), or any other event outside of the reasonable control of the Party whose performance is delayed, and (in each case) as to which Party whose performance is delayed notifies the other Party in writing within one hundred twenty (120) days after the party whose performance is delayed become aware that such event is likely to cause a delay in such party's timely performance of an obligation of such party hereunder. Notwithstanding the foregoing, if a Force Majeure Event shall occur and Tenant shall not have delivered notice to Landlord of a likely delay arising out of such Force Majeure Event, then at any given time, Landlord shall be entitled to send a notice to Tenant requesting that Tenant confirm whether or not Tenant believes such Force Majeure Event is likely, at such time, to cause a delay in Tenant's performance of the applicable obligation under this Lease. In the event that a Force Majeure Event shall occur, the time for performance of the affected covenant or duty shall be extended by a period of time equal to the period of the delay caused by such Force Majeure Event, plus, in each instance of any interruption in work, a period of time reasonably required to restart such work; provided, however, that the Party whose performance is delayed shall promptly commence and thereafter diligently pursue all reasonable and available means and measures necessary to minimize or eliminate such delay. In no event shall any financial or economic problems of Tenant hereto (or its respective affiliates, owners, shareholders, partners or members) ever be considered a cause beyond the control of Tenant or any other Force Majeure Event, but the general inability to obtain construction or other financing due to temporary contraction of or upheaval in the financing markets in the United States, or due to a material an unexpected temporary slowdown in the leasing market caused by economic forces generally, including recession, shall be considered a cause beyond the control of Tenant and a Force Majeure Event.

## ARTICLE 16

### LIENS AND ENCUMBRANCES

16.1 **No Liens.** Except for (a) the liens and security interests of any Leasehold Mortgage, (b) any liens by parties claiming by, through or under Landlord or any of its Affiliates, (c) the Permitted Encumbrances and (d) liens on any personal property or Tenant Equipment or other facility used in the operation of the Premises, and subject to Section 6.2 and Section 16.2, Tenant shall not permit any lien, charge, security interest or encumbrance of any kind whatsoever (including, without limitation, any consensual lien, any tax lien, or any vendor's, mechanic's, laborer's, materialman's, property manager's or leasing agent's statutory or similar lien) to be filed or to exist against the Premises or the Tenant Improvements or any interest of Landlord or Tenant therein by reason of any labor, services or materials supplied or claimed to have been supplied to or for the benefit of Tenant (other than Landlord or any Landlord Affiliate), including, without limitation, labor, services or materials supplied in connection with any construction, restoration or similar work pursuant to this Lease (each, an "**Unpermitted Lien**"). For avoidance of doubt, the recording of a contract in accordance with Tenn. Code Ann. § 66-11-111, by itself, shall not be deemed the creation of a mechanic's, laborer's or materialman's lien.

16.2 **Obligation to Obtain Release.** If any such Unpermitted Lien shall at any time be filed or exist against the Premises, the Tenant Improvements, Tenant's leasehold interest, or any part thereof or any estate or interest therein, Tenant shall, within thirty (30) days after Tenant receives actual notice of the filing or existence thereof, (i) cause the same to be fully and unconditionally released of record by payment or otherwise, (ii) if Tenant, in good faith, contests the lien, Tenant shall (a) provide Landlord with a letter of credit or other security to protect against the impact of such lien, or (b) bond over such lien in accordance with applicable Legal Requirements. If Tenant fails to perform its obligation set forth in the preceding sentence, Landlord shall have the right (but no obligation) to secure the release or removal of such Unpermitted Lien and charge Tenant for the actual, out of pocket costs and expense of same as Additional Rent payable immediately upon demand.

16.3 **NO SUBORDINATION.** LANDLORD'S RIGHT, TITLE, ESTATE AND INTEREST IN AND TO THE LAND, THIS LEASE, THE REVERSIONARY INTEREST IN THE TENANT IMPROVEMENTS, THE RENTS AND PROFITS THEREFROM, AND THE PROPERTY RIGHTS RELATED THERETO, IS NOT AND SHALL NOT BE SUBORDINATED TO ANY LIEN, MORTGAGE, JUDGMENT OR CLAIM OF ANY MATTER OR THING WHATSOEVER (INCLUDING, WITHOUT LIMITATION, ANY LEASEHOLD MORTGAGE) CREATED BY, OR ARISING OUT OF ANY ACT OR THING DONE OR OMITTED TO BE DONE BY, TENANT OR ANY PERSON HOLDING OR CLAIMING UNDER OR THROUGH TENANT, WHETHER CLAIMED AGAINST LANDLORD'S OR TENANT'S INTEREST IN THIS LEASE.

## ARTICLE 17

### **TITLE TO IMPROVEMENTS; SURRENDER OF PREMISES**

17.1 **Title to Tenant Improvements and Tenant Equipment; Surrender; Holding Over.** During the Term, title to the Tenant Improvements and Tenant Equipment shall be vested in Tenant, and Tenant shall be entitled to claim any depreciation deductions and investment tax credits thereon for income tax purposes to the extent that it may legally be entitled to make such claim. Tenant agrees that its interest in the Tenant Improvements and Tenant Equipment shall be subject to the terms and conditions of this Lease and that any grantees or assignees of its interest therein shall take subject to and be bound by the terms and conditions of this Lease, expressly including the following provisions:

(a) **Expiration of Lease.** In the event of the expiration or earlier termination of this Lease, however the same occurs, title to the Tenant Improvements and Tenant Equipment shall automatically vest in Landlord and Landlord shall then be and become the sole and absolute owner thereof, free of any right, title, interest, or estate of Tenant, therein, without the execution



of any further instrument and without payment of any money or other consideration thereof, except, only, that in the event of the termination of this Lease under the circumstance allowing a Leasehold Mortgagee to obtain a new lease under the provisions of Section 13.6(d), and, if at that time such Leasehold Mortgagee shall exercise its rights under Section 13.6(d), then Tenant's interest in the Tenant Improvements and Tenant Equipment, to the extent then existing, shall automatically pass to, vest in, and belong to such Leasehold Mortgagee, or any permitted successor to such Leasehold Mortgagee, until the termination of such new lease, however the same occurs. Tenant shall execute such reasonable further assurances of title as may be required to effectuate the same. Tenant hereby grants, releases, transfers, sets over, assigns, and conveys to Landlord all of its right, title, and interest in and to the Tenant Improvements and the Tenant Equipment effective upon the termination or expiration of this Lease. Nothing herein contained shall adversely affect Tenant's title to the Tenant Improvements and the Tenant Equipment and any right that Tenant may have to quiet enjoyment and possession, provided that this Lease shall continue in force and effect and there is no ongoing default on the part of Tenant hereunder by reason of which Landlord is then entitled to terminate this Lease pursuant to Section 18.2(b).

(b) Surrender. Except as otherwise set forth in Section 17.1(e) below, Tenant shall, upon the expiration or earlier termination of this Lease, surrender and deliver to the possession and use of Landlord the Premises, the Tenant Improvements and Tenant Equipment without any payment or allowance to Tenant on account of or for the Tenant Improvements and Tenant Equipment or any part thereof, without fraud or delay and in good working order and condition, as from time to time altered in compliance with this Lease, ordinary wear and tear and damage caused by fire or other casualty or condemnation for which Tenant is not responsible for the Restoration thereof hereunder excepted, and further subject to the provisions of this Lease with respect to alterations, condemnations, and damage or destruction by fire or other casualty.

(c) No Occupancy Sublease Extending Beyond Lease Term. Tenant covenants and agrees that, without the prior written consent of Landlord, it will not execute and deliver or renew any Occupancy Sublease to an Occupancy Subtenant which would extend beyond the then Term of this Lease (and for the purposes of this provision any rights of extension in any Occupancy Sublease shall be counted in the Term hereof), it being the intention of Landlord and Tenant that, except as Landlord may otherwise agree by an SNDA with a given Occupancy Subtenant or otherwise, Landlord, upon the expiration of this Lease, shall be the sole owner of the Premises, not subject to any lease or subtenant's rights of any kind.

(d) Holding Over. If Tenant shall hold possession of the Premises after the expiration or sooner termination of the Term of this Lease with Landlord's prior written consent, then Tenant shall be deemed to be occupying the Premises as a tenant from month to month subject to all of the conditions, provisions and obligations of this Lease (insofar as the same may be applicable or adjusted to a month to month tenancy), as far as applicable, except that the monthly Base Rent during such period shall be equal to one hundred fifty percent (150%) of the monthly Base Rent in effect during the last thirty (30) days of the Term, as adjusted in accordance with Section 5.2. Such tenancy shall not constitute a renewal hereof or an extension for any further term. If Tenant shall hold possession of the Premises after the expiration or sooner termination of the Term of this Lease without Landlord's prior written consent, then Tenant shall be a tenant at sufferance subject to the terms and conditions of this Lease, except that the monthly Base Rent shall be equal to one hundred fifty percent (150%) of the monthly Base Rent in effect during the last thirty (30) days of the Term, as adjusted in accordance with Section 5.2. Nothing contained in this Section 17.1(d) shall be construed as consent by Landlord to any holding over by Tenant, and Landlord expressly reserves the right to require Tenant to surrender possession of the Premises to Landlord as provided in Section 17.1(b) upon the expiration or other

termination of this Lease. The provisions of this Section 17.1(d) shall not be deemed to limit or constitute a waiver of any other rights or remedies of Landlord provided herein or at law or equity with respect to a holding over by Tenant. If Tenant fails to surrender the Premises upon the expiration or earlier termination of this Lease, Tenant shall indemnify and hold Landlord harmless from and against any and all losses, damages, costs, expenses and liabilities resulting from such failure, including, without limiting the generality of the foregoing, any claims made by any succeeding tenant founded upon such failure by Tenant to surrender the Premises, and any loss of profits and consequential, special, and indirect damages to Landlord resulting therefrom (in each case, regardless of whether such damages are foreseeable).

(e) Functionally Obsolete Improvements.

i. At any time during the last five (5) years of the Term of this Lease, but not more frequently than once per calendar year, Landlord may inspect any then-existing Tenant Improvements on the Premises and give written notice to Tenant of any Tenant Improvements that Landlord deems, in its reasonable determination based on an appraisal prepared by a Qualified Appraiser certified appraiser at Landlord's sole cost, functionally obsolete (the "Obsolescence Notice"). As used in this paragraph, "functionally obsolete" means that, with respect to any improvements on the Premises, the reasonably anticipated cost of operating the applicable Tenant Improvements and maintaining them in a reasonably good condition and repair, ordinary wear and tear excepted, for the remainder of the Term would exceed the fair market value of such improvements at such time. If Tenant objects to Landlord's determination that any improvements on the Premises are functionally obsolete as set forth in the Obsolescence Notice, then Tenant must give written notice to Landlord of such objection within sixty (60) days after receiving the Obsolescence Notice, in which case the determination of whether the improvements set forth in the Obsolescence Notice are functionally obsolete shall be determined by a Qualified Appraiser selected as set forth below, and both parties must share equally in the cost and expenses of such appraiser. Within fifteen (15) days after Landlord receives written notice of Tenant's objection to the Obsolescence Notice, Landlord and Tenant shall each appoint a Qualified Appraiser. The two appraisers so appointed shall within thirty (30) days of their appointment select a third appraiser meeting such qualifications, who will make the determination required by this Section 17.1(e), which shall be conclusive and binding on Landlord and Tenant as to whether the improvements set forth in the Obsolescence Notice are functionally obsolete. For purposes of Section 17.1(e)ii. below, the determination that an improvement on the Premises is functionally obsolete shall be deemed to have occurred on the date that is sixty-one (61) days after an Obsolescence Notice with respect to such improvement has been received by Tenant unless Tenant objects to such Obsolescence Notice as set forth above, in which case the determination will be deemed to have occurred on the date that the third appraiser delivers to Landlord and Tenant a written report that concludes that such improvement is functionally obsolete. As used herein, "**Qualified Appraiser**" means a MAI-certified appraiser residing in Davidson County, Tennessee with at least ten (10) years' experience.

ii. If any Tenant Improvements on the Premises are determined to be functionally obsolete pursuant to Section 17(e)(i), then Landlord may, by written notice to Tenant delivered within ninety (90) days of such determination, request that Tenant demolish and remove the functionally obsolete Tenant Improvements ("**Removal Notice**").

iii. If Landlord timely delivers such Removal Notice to Tenant, then Tenant must demolish and remove the functionally obsolete Tenant Improvements prior to the expiration of the original Term or the then-current Extension Period (as applicable) unless (x) Tenant elects, in its sole discretion, and agrees in writing to surrender the functionally obsolete Tenant Improvements at the end of the Term in reasonably good condition and repair, ordinary wear and tear excepted, reasonably

clean and safe, and in compliance with all Legal Requirements, or (y) Tenant delivers to Landlord evidence that the portion of the Premises on which the functionally obsolete improvements are located is subject to an Occupancy Sublease and that such Occupancy Sublease requires the applicable Occupancy Subtenant to maintain the functionally obsolete improvements in at least as good condition and repair as set forth in clause (x) above.

iv. If Landlord fails to timely deliver a Removal Notice with respect to any improvements determined to functionally obsolete as set forth above, then Tenant shall have no obligation under this Lease with respect to such functionally obsolete improvements other than to maintain the improvements in accordance with the terms of this Lease.

17.2 **Re-Entry.** Landlord, upon termination of this Lease for any reason, may, without notice, re-enter upon the Premises and possess itself thereof by summary proceedings, ejectment, or otherwise, and may dispossess Tenant and remove Tenant and all other persons and property from the Premises which it may elect so to dispossess, other than (a) Occupancy Subtenants (except to the extent any of them may be removed in accordance with the terms of their respective Occupancy Subleases, including, without limitation, by reason of being in default thereunder after any applicable notice and cure period), (b) any Occupancy Subtenants with respect to which Landlord has entered into Subordination, Nondisturbance and Attornment Agreements which are in force and effect (except to the extent provided in such SNDAs or the applicable Occupancy Subleases), and (c) any parties with or as to which Landlord has otherwise agreed, and Landlord may thereafter enjoy the Premises and have the right to receive all rents income from the same, without hindrance or interference from Tenant or anyone claiming by, through, or under Tenant, other than the aforesaid Occupancy Subtenants and parties, if any, with the right to remain on the Premises. Occupancy Subtenants or other parties which must leave the Premises may remove their personal property and trade fixtures therefrom, provided that any such party repairs any damage caused by its removal. Any personal property of any such parties remaining on the Premises beyond thirty (30) days after termination of this Lease shall be treated as having been abandoned and may be retained by Landlord as its sole property or be disposed of, without liability or accountability, as Landlord sees fit.

17.3 **Confirming Documents.** Tenant shall execute such reasonable documentation as Landlord may require to transfer or confirm the transfer of title to the Tenant Improvements and Tenant Equipment to Landlord, as hereinabove set forth.

17.4 **Survival.** Tenant's obligation to observe and perform the covenants under this Article 17 shall survive the expiration or earlier termination of the Term.

## ARTICLE 18

### **DEFAULT; REMEDIES OF DEFAULT**

18.1 **Event of Default Defined.** The occurrence of any of the following shall constitute an event of default under this Lease by Tenant (each, an "**Event of Default**" and, collectively, "**Events of Default**"):

(a) **Compliance with Orders from Court or Governmental Authority.** If Tenant fails to comply with an order of a court of competent jurisdiction or of a Governmental Authority with respect to the Premises or the Tenant Improvements within the required time period and such failure is not cured within thirty (30) days thereafter.

(b) **Failure to Pay Base Rent.** Tenant shall have failed to pay any installment of Base Rent within thirty (30) days after the date on which such installment is due.

(c) Failure to Pay Additional Rent. Tenant shall have failed to pay any Additional Rent, or failed to perform any other obligation of Tenant requiring the payment of money to Landlord under the terms of this Lease (other than the payment of Base Rent) and such failure shall not be cured within thirty (30) days after written notice thereof from Landlord; provided, however, that (i) Tenant may contest Impositions as expressly set forth in this Lease, and (ii) Tenant may, in good faith, and at its cost and expense, contest the amount or validity of any other Additional Rent, in an appropriate manner or by appropriate proceedings so long as (A) there will be no sale, forfeiture or loss of any portion of the Premises during the contest, (B) Landlord is not subjected to any Liability as a result of such contest, and (C) Tenant either pays the contested amount under protest or otherwise provides Landlord notice of such contest together with assurances satisfactory to Landlord of its ability to pay such Additional Rent in the event Tenant is unsuccessful in its contest. There shall be no Event of Default pursuant to this Section 18.1(c) so long as any contest as described in and pursuant to the terms of clause (i) and (ii) above is ongoing.

(d) Tenant Abandonment. If Tenant abandons the Premises or any substantial portion thereof and fails to operate the Premises under the terms of this Lease for a period of more than twenty-four (24) consecutive months for any reason other than Force Majeure Events, the process of restoration following a Casualty or Taking, or other Permitted Closures; it being acknowledged that, so long as Tenant is listing the Premises for sale or lease and maintaining the Premises in the condition required by this Lease, no abandonment shall be deemed to have occurred. For purposes of this clause (e), abandonment means Tenant and all Subtenants have ceased operations at, and vacated, the entire Premises.

(e) Failure to Perform Lease Covenant. Tenant shall have failed to perform any terms, covenant, or condition of this Lease to be performed by Tenant, other than as set forth in the other subparagraphs of this Section 18.1 and except those requiring only the payment of money, and such failure shall not be cured within thirty (30) days after written notice thereof from Landlord, except that, where such failure could not reasonably be cured within said thirty (30)-day period, Tenant shall not be in default, and no Event of Default shall exist, unless Tenant shall have failed (a) to commence to cure such default within said thirty (30) days, or (b) thereafter to make diligent, reasonable, and continuous efforts to cure such failure as soon as practicable but in no event more than one hundred twenty (120) days.

(f) Bankruptcy. If (i) a court made or entered any decree or order adjudging Tenant or Guarantor to be bankrupt or insolvent; (ii) a petition in bankruptcy or other insolvency proceeding seeking either liquidation or reorganization of Tenant or Guarantor or an arrangement under the bankruptcy laws or any other applicable debtor's relief law or statute of the United States or any state thereof is filed against Tenant or Guarantor and not dismissed within ninety (90) days thereafter; (iii) a receiver, trustee or assignee of Tenant or Guarantor in bankruptcy or any insolvency proceeding or for its property is appointed and not discharged or dismissed within ninety (90) days thereafter; (iv) a court made or entered any decree directing the winding up or liquidation of Tenant or Guarantor and such decree or order shall continue without being vacated or dismissed for a period of ninety (90) days; or (v) Tenant or Guarantor voluntarily submitted to or filed a petition seeking any such decree or order or relief under any federal or state bankruptcy or insolvency laws.

(g) Attachment or Seizure. The subjection of any right or interest of Tenant in this Lease to attachment, execution, or other levy, or to seizure under legal process, if not released or Tenant has not otherwise bonded off or provided other reasonable security in connection

therewith, within sixty (60) days; provided that the foreclosure of any Leasehold Mortgage shall not be construed as an Event of Default within the meaning of this subsection (g).

(h) Failure to Commence Construction. If Tenant fails or refuses to comply with Section 4.4(a)(i) hereof within the time periods and in the manner set forth therein, and such failure is not cured within fifteen (15) Business Days after Landlord's notice of such failure.

**18.2 Rights and Remedies of Landlord**. Upon an Event of Default, subject to the provisions of Section 18.2(b) and Section 18.2(c), Landlord shall have the following remedies, in addition to all other rights and remedies provided by law or otherwise provided in this Lease, to which Landlord may resort cumulatively, or in the alternative and in any order:

(a) Landlord shall have the right to proceed by appropriate judicial proceedings, either at law or in equity, to enforce the performance or observance by Tenant of the applicable provisions of this Lease, including, without limitation, seeking specific performance, injunctive relief, recovery of damages, and/or other equitable remedies for a breach of Tenant's obligations hereunder, Tenant acknowledging that such remedies are appropriate for a breach of its obligations hereunder.

(b) Upon the occurrence and during the continuance of an Event of Default described in Section 18.1 (b), (c), (d), (f), (g), and (h), Landlord may either (x) at Landlord's election, keep this Lease in effect and enforce all of its rights and remedies under this Lease, including the right to recover the Rent and other sums as they become due by appropriate legal action or (y) (subject to the provisions of Article 13 regarding the rights of Leasehold Mortgagees), terminate this Lease upon, not less than thirty (30) days' prior written notice to Tenant, whereupon this Lease and the Term shall expire and terminate and Landlord shall thereupon have the right without further notice and either with or without process of law, to the extent permitted by law, to reenter the Premises and to remove Tenant and to repossess the Premises. Any termination under this Section 18.2(b) shall not relieve Tenant from the payment of any sums then due to Landlord or from any claim for damages or rent previously accrued or then accruing against Tenant. If Tenant shall cure an Event of Default described in Sections 18.1(b), (c), (d), (g), and (h) after Tenant's receipt of Landlord's termination notice given pursuant to this Section 18.2(b) prior to the effective date of any such termination, Landlord's termination notice shall be void and of no further force and effect and this Lease shall continue in accordance with its terms. Notwithstanding the foregoing, if there shall occur any Event of Default described in Sections 18.1(a) or 18.1(e) and Landlord shall prevail in obtaining a final judgment (beyond any available appeals) obligating Tenant to pay Landlord damages for such Event of Default, and Tenant shall thereafter fails to pay to Landlord the damages awarded in such final judgment with sixty (60) days of the date of such final judgment, then Landlord may, subject to the provisions of Article 13 regarding the rights of Leasehold Mortgagees, terminate this Lease upon, not less than thirty (30) days' prior written notice to Tenant, whereupon this Lease and the Term shall expire and terminate and Landlord shall thereupon have the right without further notice and either with or without process of law, to the extent permitted by law, to reenter the Premises and to remove Tenant and to repossess the Premises.

(c) Notwithstanding the foregoing to the contrary, if there shall be an Event of Default pursuant to Section 18.1(g) and such Event of Default arises out of the occurrence of any of the events listed in (i)-(v) therein solely with respect to the Guarantor, then Tenant shall have sixty (60) days from the occurrence of such event to replace Guarantor with a guarantor meeting the requirements of a Pre-Approved Guarantor under the Development Agreement or any other Person approved by Landlord in Landlord's sole discretion.

(d) Notwithstanding anything to the contrary contained herein, Landlord acknowledges and agrees that Landlord shall in no event have the right to terminate this Lease as a result of any breach, default or Event of Default hereunder or for any other reason, except for Landlord's termination right expressly set forth in Section 18.2(b).

18.3 **Right of Re-entry.** Following a termination of this Lease in accordance with Section 18.2(b), and at any time or from time to time following such termination, Landlord may, at Landlord's election, re-enter and take possession of the Premises and relet the Premises or any part or parts of it for the account and in the name of Tenant or otherwise. Tenant agrees, upon the termination of the Lease, to at once surrender possession of the Premises, to Landlord. Tenant expressly waives (to the full extent permitted by law) the service of any other notice of intention to terminate this Lease or of intention to re-enter which may be presently provided for by any statute or other law or any future amendment or similar statute or law (so long as, in the case of a future amendment or statute or law, the remedies to be exercised by Landlord are not substantially different than the remedies presently available to Landlord). No receipt of money by Landlord from Tenant after any termination, howsoever occurring, of this Lease shall reinstate, continue or extend the Term of this Lease (unless so agreed at such time).

18.4 **Late Fees and Default Interest.** Late payment by Tenant to Landlord of Base Rent and other sums due shall cause Landlord to incur costs not contemplated by this Lease, the exact amount of which is extremely difficult and impracticable to ascertain. Therefore, if any installment of Base Rent due from Tenant is not received by Landlord within two (2) days after the date that Landlord notifies Tenant that such payment is overdue, Tenant shall pay to Landlord an additional sum of five percent (5%) of the overdue Base Rent as a late charge, provided, however, that Landlord shall not be required to give written notice of the same delinquency more than twice in any calendar year, and, at Landlord's election, a subsequent failure to timely pay such Base Rent when due shall immediately result in the imposition of such late charge. Furthermore, if any installment of Base Rent due from Tenant is not received by Landlord within fifteen (15) days after the date such payment is due, Tenant shall pay to Landlord interest at an annual rate equal to the Default Rate. The parties agree that the foregoing late charges and Default Rate of interest represent fair and reasonable estimates of the costs that Landlord will incur by reason of late payment by Tenant and shall be payable as Additional Rent to Landlord due with the next installment of Rent. Landlord's acceptance of any Additional Rent (including a late charge or any other amount hereunder) shall not be deemed an extension of the date that Rent is due or prevent Landlord from pursuing any other rights or remedies under this Lease, at law, or in equity.

18.5 **Landlord's Right to Cure.** If an Event of Default occurs and remains uncured under this Lease, Landlord, without waiving such default, may perform such obligations at Tenant's expense: (a) immediately, and without notice, in the case of emergency or if the Event of Default results in a violation of any Legal Requirement or will result in a cancellation of any insurance policy maintained by Landlord or to relieve a situation which threatens the physical well-being of persons or damage to property in the Tenant Improvements or adjacent property, or (b) if Tenant does not commence the cure or such failure within the applicable cure periods set forth in this Lease, or (c) once such cure is commenced, Tenant permits a lapse in the commercially reasonable pursuit of such cure; and in such event, Tenant shall reimburse Landlord, as Additional Rent, for all reasonable, out-of-pocket costs and expenses incurred by Landlord in connection therewith, together with interest thereon at the Default Rate until paid.

## ARTICLE 19

### **REMEDIES CUMULATIVE**

19.1 **Remedies Cumulative.** The specified remedies to which Landlord or Tenant may resort under the terms of this Lease are cumulative and are not intended to be exclusive of any other remedies or

means of redress to which Landlord or Tenant may be lawfully entitled in case of any breach or threatened breach by Landlord or Tenant, as the case may be, of any provision of this Lease. The failure of Landlord or Tenant to insist in any one or more cases upon the strict performance of any of the covenants of this Lease, or to exercise any option herein contained, shall not be construed as a waiver or a relinquishment for the future of such covenant or option.

19.2 **Acceptance of payments.** A receipt by Landlord of rents, with knowledge of the breach of any covenant hereof, shall not be a waiver of such breach, and no waiver by Landlord or Tenant of any provision of this Lease shall be effective unless in writing and signed by the Party granting the waiver. Acceptance by Landlord (including, without limitation, of any draft remitting the same) of payments in amounts less than due Landlord shall be treated as payments on account to the extent thereof, notwithstanding any statement or endorsement on or accompanying the same; and the acceptance of payment by Landlord from any person other than Tenant on account of Tenant's obligations shall not be treated as a waiver by Landlord of any right Landlord may have on account of an improper transfer of Tenant's interest under this Lease.

19.3 **Restraining Orders.** In addition to the other remedies in this Lease provided, Landlord and Tenant shall be entitled to restraint of the other, as the case may be, by injunction of the violation, or attempted or threatened violation, of any of the covenants, conditions and provisions of this Lease.

## ARTICLE 20

### **QUIET ENJOYMENT**

20.1 **Landlord's Covenant.** So long as this Lease remains in full force and effect and no Event of Default exists, Tenant shall and may peaceably and quietly have, hold and enjoy the Premises for the Term hereby granted without molestation or disturbance by or from Landlord or any Person claiming through or under Landlord and free of any encumbrance created or suffered by Landlord, except for the Permitted Encumbrances and any encumbrances created or permitted by Tenant. This covenant shall be construed as running with the Land to and against subsequent owners and successors in interest and is not, nor shall it operate or be construed as, a personal covenant of Landlord, except to the extent of Landlord's interest in the Premises and only for so long as such interest shall continue, and thereafter this covenant shall be binding upon such subsequent owners and successors in interest of Landlord's interest under this Lease, to the extent of their respective interests, as and when they shall acquire the same, and only for so long as they shall retain such interest.

## ARTICLE 21

### **ADDITIONAL COVENANTS AND REPRESENTATIONS**

#### 21.1 **Additional Covenants.**

(a) **Conduct of Business.** Tenant hereby covenants and agrees that, during the Term of this Lease and following Final Completion, Tenant will conduct and maintain the business operation of the Premises in compliance, in all material respects, with all applicable Legal Requirements and in accordance with this Lease.

(b) **Notification of Disputes.** Tenant hereby covenants and agrees that, during the Term of this Lease, Tenant will promptly notify Landlord of any materially adverse claims, actions or proceedings affecting the Premises or the performance of its obligations under this Lease.

(c) **Notification of Attachments.** Tenant hereby covenants and agrees that, during the Term of this Lease, Tenant will promptly notify Landlord of any levy, attachment, execution or other process against Tenant's assets, which will materially adversely affect the Premises or the performance of its obligations under this Lease.

(d) **Agency Reports/Documentation.** Tenant hereby covenants and agrees that, during the Term of this Lease, Tenant will provide Landlord with copies of any material written reports or other material written documentation that Tenant furnishes to or receives from any Governmental Authority relative to the Premises.

(e) **Further Assurances.** Each of Tenant and Landlord hereby covenants and agrees that, upon request by the other Party at any time during the Term of this Lease, it will execute and deliver, or cause to be executed and delivered, such further instruments and do or cause to be done such further acts, as may reasonably be necessary or proper to carry out the intent and purpose of this Lease.

(f) **Reimbursement Rights.** Tenant hereby covenants and agrees that, during the Term of this Lease, it will reimburse the Landlord for all reasonable legal expenses incurred by Landlord in connection with (a) all requests for consent or approval of any actions or documents requested by the Tenant or (b) any Leasehold Mortgage or Mezzanine Financing.

(g) **Landlord's Covenant Regarding Access.** Landlord shall use reasonable efforts to ensure that sufficient streets remain open so as to allow a point of access to the Building.

## 21.2 **Tenant Representations.**

(a) As of the Lease Commencement Date, Tenant represents and warrants that Tenant is a limited liability company duly organized, validly existing and in good standing under the laws of the State of \_\_\_\_\_; that Tenant is an Affiliate of Developer [NTD: **Not applicable to Affordable Developer**]; that Tenant is qualified to do business in the State of Tennessee; that Tenant has the legal right, power and authority to enter into and perform all of its obligations under this Lease; that the individuals executing this Lease have been duly authorized, after all requisite action of Tenant, to execute the same on behalf of, and to bind, Tenant; and that all of the obligations of Tenant set forth herein are enforceable against Tenant in accordance with their respective terms.

(b) As of the Lease Commencement Date, Tenant represents and warrants that its execution of this Lease and compliance with their terms will not conflict with or result in a breach of any law, judgment, order, writ, injunction, decree, rule or regulation of any court, administrative agency or other governmental authority to which Tenant is subject, or any other agreement, document or instrument by which Tenant is bound. Tenant further represents and warrants that there are no claims, lawsuits or proceedings to which Tenant is a party pending in any court or government agency, the outcome of which could materially and adversely affect Tenant's ability to perform its obligations under this Lease.

(c) As of the Lease Commencement Date, Tenant represents and warrants that Tenant has not filed any petition, nor has Tenant been the party against whom a petition has been filed in relation to any bankruptcy, insolvency, request for reorganization, the appointment of a receiver or trustee, or the arrangement of debt, nor, to the best of Tenant's knowledge, is any such action contemplated or threatened.



(d) As of the Lease Commencement Date, Tenant acknowledges and agrees that Tenant has not been influenced to enter into this Lease by, nor has it relied upon, any representations or warranties of Landlord or any of Landlord's Affiliates whatsoever, except as set forth in this Lease or in the Development Agreement.

(e) As of the Lease Commencement Date, Tenant represents and warrants that neither Tenant nor any of Tenant's Affiliates is a Prohibited Person.

### 21.3 **Landlord Representations.**

(a) As of the Lease Commencement Date, Landlord represents and warrants Landlord has the legal right, power and authority to enter into and perform all of its obligations under this Lease; that the individuals executing this Lease have been duly authorized after all requisite action of Landlord, to execute the same on behalf of, and to bind, Landlord; and that all of the obligations of Landlord set forth herein are enforceable against Landlord in accordance with their respective terms.

(b) As of the Lease Commencement Date, Landlord represents and warrants that its execution of this Lease and compliance with their terms will not conflict with or result in a breach of any law, judgment, order, writ, injunction, decree, rule or regulation of any court, administrative agency or other governmental authority to which Landlord is subject, or any other agreement, document or instrument by which Landlord is bound. Landlord further represents and warrants that there are no claims, lawsuits or proceedings to which Landlord is a party pending in any court or government agency, the outcome of which could materially and adversely affect Landlord's ability to perform its obligations under this Lease or the Joinder.

(c) As of the Lease Commencement Date, Landlord represents and warrants that Landlord has not filed any petition, nor has Landlord been the party against whom a petition has been filed in relation to any bankruptcy, insolvency, request for reorganization, the appointment of a receiver or trustee, or the arrangement of debt, nor, to the best of Landlord's knowledge, is any such action contemplated or threatened.

(d) As of the Lease Commencement Date, Landlord represents and warrants that neither Landlord nor any of Landlord's Affiliates is a Prohibited Person.

## ARTICLE 22

### **LANDLORD TRANSFERS**

22.1 **Landlord Transfers.** Notwithstanding any other provision contained in this Lease to the contrary, except for Landlord Transfers expressly permitted under clause (x) or (y) of the proviso to this sentence, Landlord shall not assign this Lease or any of Landlord's rights or obligations hereunder without Tenant's prior written consent in each instance; provided, however, that (x) without Tenant's consent, Landlord may assign this Lease and all rights and obligations of Landlord hereunder (a "**Landlord Transfer**") as set forth in Section 22.2 below, subject to and in accordance with the terms thereof, and (y) following the twentieth (20<sup>th</sup>) anniversary of the Substantial Completion Date, Landlord may effectuate a Landlord Transfer without Tenant's consent but subject to subject to and in accordance with the following provisions:

(a) In the event that Landlord desires to effectuate a Landlord Transfer, then, prior to entering into an agreement regarding the Premises, Landlord will first deliver a written notice

of such contemplated sale to Tenant (“**Offer Notice**”), and Tenant shall have the right to make an offer to Landlord to purchase the Premises on the terms set forth below (such right being referred to herein as the “**ROFO Option**”). If Tenant wishes to acquire the Premises, Tenant shall reply to the Offer Notice with a notice (the “**ROFO Offer**”), which must be received by Landlord within sixty (60) days after delivery of the Offer Notice. The ROFO Offer shall include a proposed purchase price (the “**ROFO Price**”) for the Premises, which will be for all cash consideration to be paid at the closing.

(b) At any time within the 120-day period following Landlord receipt of the ROFO Offer, Landlord may, by written notice to Tenant, either (1) reject the ROFO Offer, in which event Landlord shall have to the right to sell the Premises in accordance with the remainder of this Section, or (2) accept the ROFO Offer on the terms set forth in the ROFO Offer.

(c) If Landlord accepts the ROFO Offer within such 120-day period, the closing shall be on a date established by mutual agreement of Landlord and Tenant but not sooner than ninety (90) days after such acceptance. Any sale of the Premises pursuant to the ROFO Option will be for all cash, for all of the Premises, “as is, where is” and with no representations or warranties by Landlord as to the Premises except a customary closing representation to the effect that Landlord has not conveyed or pledged such fee interest to any other party. If Landlord rejects the ROFO Offer or fails to respond to the ROFO Offer within such 120-day period, Landlord may proceed to sell its fee interest in the Premises to a third party free of the ROFO Option; provided however, that (x) Landlord may not sell its interest for less than 95% of the ROFO Price or on materially more favorable terms than set forth in the ROFO Offer to such third party without first delivering an Offer Notice to Tenant and repeating the process set out above, and (y) if Landlord fails to enter into a binding contract with a third party (subject only to Metro Council approval) within nine (9) months after Landlord’s rejection of Tenant’s ROFO Offer or fails to complete such transaction within fifteen (15) months after entering into such binding contract, Landlord will not sell or offer to sell the Landlord’s fee interest in the Premises without first delivering an Offer Notice to Tenant and repeating the process set out above.

(d) In connection with the sale of the Premises with respect to which either (i) Tenant has not elected to exercise its ROFO Option as set forth above or (ii) the ROFO Offer has been rejected or waived by Landlord as set forth above, Tenant shall deliver to Landlord and any prospective purchaser within ten (10) days after request therefor, a duly executed, validly authorized written statement confirming that the ROFO Offer is not applicable to such sale. Promptly upon completion of such sale, Landlord shall provide Tenant with a written notice setting out the purchaser’s name, notice address and a contact person.

(e) Upon any Landlord Transfer (other than an East Bank Authority Transfer made pursuant to Section 22.2 below), the following sections of this Lease shall be amended and restated or deleted, in each case as more particularly set forth on **Exhibit J** attached hereto: Section 2.4, Section 4.4(d), Section 4.8(a), Section 12.1, Section 14.1, Section 13.6(d), and Section 17.1(e).

**22.2 East Bank Authority.** Notwithstanding any other provision contained in this Lease to the contrary, Landlord may, without Tenant’s consent, do any of the following (each, an “**East Bank Authority Transfer**”): (i) convey fee title to the Premises (and any other land in the Campus) to the East Bank Authority, (ii) assign this Lease or delegate all of its duties under this Lease to the East Bank Authority, and (iii) lease the Premises (and any other land in the Campus) to the East Bank Authority; provided, however, that (x) no such assignment or transfer may affect Tenant’s rights under this Lease, and (y) in connection with a lease of the Premises to the East Bank Authority as described in (iii) above, Landlord

must execute, and must cause the East Bank Authority to execute, such estoppel certificates, non-disturbance agreements, and other similar agreements and instruments as Tenant or any Permitted Leasehold Mortgagee may reasonably request. Landlord shall provide at least fifteen (15) Business Days' prior written notice to Tenant of any East Bank Authority Transfer. In the event that Landlord assigns this Lease in whole to the East Bank Authority, then the East Bank Authority shall assume obligations of Landlord under this Lease arising from and after the date of the East Bank Authority Transfer, provided that Landlord shall remain liable for any obligations of Landlord accruing prior to the East Bank Authority Transfer. No later than seven (7) Business Days following the effective date of any East Bank Authority Transfer permitted hereunder, Landlord shall provide to Tenant a copy of the instrument effectuating such Landlord Transfer. If Landlord Transfers fee title to the Premises to the East Bank Authority without assigning this Lease to the East Bank Authority, then this Lease shall continue in full force and effect as a sublease between Landlord and Tenant, subject to the foregoing provisions of this Section 22.2. If Landlord leases the Premises to the East Bank Authority, then this Lease will continue in full force and effect as a sublease between the East Bank Authority and Tenant, subject to the foregoing provisions of this Section 22.2. In connection with an East Bank Transfer, Tenant hereby agrees to execute and deliver, or cause to be executed and delivered, in form and substance reasonably acceptable to Tenant, such amendments to this Lease and further instruments as may reasonably be requested by Landlord or the East Bank Authority to reflect a change in the identity of Landlord, the conversion of this Lease to a sublease, or any similar changes necessary as a result of an East Bank Authority Transfer.

22.3 **Fee Mortgage.** Landlord hereby reserves the right to place one or more mortgages or deeds of trust in favor of a third-party lender (a "**Fee Mortgagee**") upon the entire fee simple title to the Land or the Premises, or any part thereof, as the same may be refinanced, renewed, modified, amended, extended, consolidated or coordinated from time to time (a "**Fee Mortgage**"). Any Fee Mortgage granted by Landlord shall be expressly subject and subordinate to this Lease (and any new lease entered into pursuant to Section 13.6) and concurrently with the execution and delivery of any Fee Mortgage, Landlord shall obtain and deliver to Tenant a commercially reasonable agreement by the applicable Fee Mortgagee, pursuant to which (i) such Fee Mortgagee consents to this Lease, acknowledges that (x) the Fee Mortgage is subject and subordinate to this Lease (and any new lease entered into pursuant to Section 13.6) and (y) the rights of the Leasehold Mortgagee as set forth in this Lease shall be superior, in all respects, to the rights of such Fee Mortgagee and agrees that, notwithstanding the terms of the applicable Fee Mortgage held by such Fee Mortgagee, or any default, expiration, termination, foreclosure, sale, entry or other act or omission under or pursuant to such Fee Mortgage, or such Fee Mortgagee's exercise of any of its rights and/or remedies under such Fee Mortgage or a transfer in lieu of foreclosure, Tenant shall not be disturbed in quiet enjoyment of the Premises nor shall this Lease be terminated or cancelled at any time, except in the event that Landlord shall have the right to terminate this Lease under the terms and provisions expressly set forth herein, and (ii) Tenant shall agree that Tenant will attorn to and recognize such Fee Mortgagee or the purchaser at any foreclosure sale or any sale under a power of sale contained in any such Fee Mortgage or the transferee accepting a deed in lieu of foreclosure as Landlord under this Lease for the balance of the Term of this Lease then remaining.

## ARTICLE 23

### ENVIRONMENTAL MATTERS

23.1 **Hazardous Materials.** No Hazardous Materials shall be used, treated, kept, stored, transported, handled, sold or Released at, on, under or from the Premises during the Term, except in strict compliance with all Environmental Requirements. Notwithstanding the foregoing, Tenant and its Affiliates and Subtenants may use (i) any hazardous or toxic materials, substances, oils, or other products as are usually and customarily used in connection with the use, operation, maintenance, and repair of the Premises contemplated by this Lease, (ii) customary and reasonable quantities of standard janitorial and office

products, and (iii) such products as are incorporated into the functioning of building systems (e.g., HVAC units and elevators) or as are necessary to the use permitted at the Premises, and then, in each case, only in compliance with all applicable Legal Requirements. To the extent Tenant or any Subtenant is required by any Environmental Requirements to maintain an inventory of Hazardous Materials used on the Premises and to file such inventory with any environmental agency, Tenant shall obtain and provide a current copy of such inventory to Landlord.

23.2 **Definitions.** The following terms shall be defined as indicated for the purposes of this Lease:

(a) **Environmental Requirements.** “Environmental Requirements” shall mean, collectively, all applicable federal, state or local law, whether common law, statutes, rules, regulations, codes, ordinances, directives, orders, decrees or judicial or administrative decision or policy or guideline (whether now existing or hereafter enacted, promulgated or issued), respecting the protection of the environment or health and safety, and the assessment, remediation, removal or disposal of Hazardous Materials, including, without limitation, those identified in the definition of “Hazardous Materials”, and the regulations promulgated under each of such statutes or laws, all as amended from time to time.

(b) **Release.** “Release” with respect to Hazardous Materials, shall mean any release, deposit, discharge, emission, leaking, spilling, seeping, migrating, injecting, pumping, pouring, emptying, escaping, dumping, disposing, or other movement of Hazardous Materials into the environment; provided that release shall not include the migration, seepage or discharge on, over or across the Premises of any Hazardous Materials that originates off of the Premises.

(c) **Known Existing Conditions.** “Known Existing Conditions” shall mean all matters related to Hazardous Materials on the Premises or the Premises’ compliance with Environmental Requirements that are set forth in the Environmental Report.

(d) **Pre-Existing Environmental Conditions.** “Pre-Existing Environmental Conditions” shall mean, collectively, Known Existing Conditions and Unknown Existing Conditions.

(e) **Unknown Existing Conditions.** “Unknown Existing Conditions” shall mean the environmental conditions existing as of the effective date of the Environmental Report that are not Known Existing Conditions.

(f) **Future Environmental Conditions.** “Future Environmental Conditions” shall mean any environmental conditions on the Premises first arising after the Lease Commencement Date; *provided, however,* that Future Environmental Conditions exclude Future Migration Conditions.

(g) **Future Migration Conditions.** “Future Migration Conditions” include contamination determined (or agreed by the Parties) to have migrated onto the Premises from any land owned by Landlord, other than land leased pursuant to another Ground Lease.

23.3 **Indemnifications and Releases for Environmental Claims.** Tenant hereby releases and forever discharges the Landlord Parties for all Liabilities other than third party Liabilities which first accrued prior to the Effective Date of this Lease, arising out of the Pre-Existing Environmental Conditions. Tenant shall indemnify, defend, and hold harmless the Landlord Parties from and against any and all Liabilities arising out of any claim for any loss or damage to property, injuries to or death of persons, any contamination of or adverse effects on the environment, or any violation of Environmental Requirements

caused by or resulting from Future Environmental Conditions or any breach by Tenant of the provisions of this Article 20.

23.4 **Obligation to Notify**. If Tenant shall become aware of or receive notice or other communication in writing concerning any actual, alleged, suspected or threatened violation of Environmental Requirements, or any claim, notice or other communication concerning any actual or threatened investigation, inquiry, lawsuit, claims, citation, directive, summons, proceeding, complaint, notice, order, writ, or injunction, relating to same, then Tenant promptly shall deliver to Landlord a written description of said notice or other communication, and documentation of any corrective action or mitigation measures undertaken or requested by Tenant.

23.5 **Right to Remediate**. Should Tenant fail to perform or observe any of its obligations or agreements pertaining to Hazardous Materials or Environmental Requirements under this Article 23, then Landlord shall have the right, but not the obligation, after the expiration of applicable notice and cure periods, without limitation of any other rights of Landlord hereunder, to enter the Premises personally or through agents of Landlord and perform the same. Tenant agrees to indemnify Landlord for the costs thereof and liabilities therefrom as set forth above in this Article 23.

23.6 **Acknowledgments of Tenant**. Tenant represents and acknowledges, subject to the Scope of Work Document, that Tenant is aware that, prior to the Lease Commencement Date, the Premises contained the Pre-Existing Environmental Conditions.

23.7 **General Provisions**.

(a) The obligations of Tenant under this Article 23 shall not be affected by any investigation by or on behalf of Landlord, or by any information which Landlord may have or obtain as a result of any such investigation.

(b) The provisions of this Article 23 shall survive any termination of this Lease.

(c) The obligations of Tenant and Landlord under this Article 23 shall not be affected in any way by the absence of covering insurance or by the failure or refusal of any insurance carrier to perform any obligation on its part under insurance policies affecting the Premises or any part thereof.

**ARTICLE 24**

**Reserved**.

**ARTICLE 25**

**DISPUTE RESOLUTION**

25.1 **General**. Landlord and Tenant shall endeavor to resolve any disputes relating to this Lease through reasonable business-like dispute resolution procedures. To the extent a dispute arises that relates to (i) a design, construction, Future Project Approvals, Future Project Approvals Filing, or permitting efforts matter under Article 4 or (ii) the reasonableness of Landlord's withholding, delay or conditioning of its approval, then either Party may deliver written notice to the other Party requesting dispute resolution under this Article 25 (the "**Dispute Notice**"), and specifying the nature of the dispute to be addressed (the "**Dispute**"). This dispute resolution procedure may be conducted before or during the pendency of any other legal proceedings, and either Party shall be entitled to bring any legal or judicial action to enjoin an act or

proposed act by the other Party which is in dispute, or seek any other ancillary relief to preserve the status quo or protect the rights of either Party, pending the commencement or completion of any dispute resolution process.

25.2 **Resolution Proposal.** Initially, the Dispute Notice shall also include in reasonable detail the requesting Party's final proposal with respect to the Dispute, which, if agreed to by the responding Party, would resolve the Dispute (the "**Dispute Resolution Proposal**"). The responding Party shall have seven (7) Business Days after its receipt of the Dispute Resolution Proposal (the "**First Dispute Resolution Period**") to either accept or reject the Dispute Resolution Proposal. If the responding Party accepts the Dispute Resolution Proposal, then the Dispute shall be deemed resolved.

25.3 **Meet and Confer.** If the responding Party rejects, or otherwise fails to respond to, the Dispute Resolution Proposal within the First Dispute Resolution Period, then the Dispute shall be referred to the parties' respective Senior Executives, and the parties shall cause their respective Senior Executives to meet at least once (in person, or by telephone or video conference) within seven (7) Business Days after the expiration of the First Dispute Resolution Period (the "**Second Dispute Resolution Period**") and negotiate in good faith to resolve the Dispute. If a Party designates a designee in lieu of the Chief Executive Officer as the Senior Executive, then such designee must have reasonable familiarity with the Project and the Dispute, and the authority to resolve the Dispute on terms other than such Party's position.

25.4 **Other Remedies.** If the Senior Executives fail to resolve the Dispute to their mutual satisfaction before the expiration of the Second Dispute Resolution Period, then either Party may pursue any and all rights and remedies that it may have under this Lease or applicable law.

## ARTICLE 26

### **NON-DISCRIMINATION AND AFFIRMATIVE ACTION**

26.1 **Compliance with Equal Opportunity Laws and Regulations.** Tenant shall comply in all material respects with all applicable Legal Requirements in effect from time to time pertaining to Equal Employment, Anti-Discrimination and Affirmative Action, including executive orders and rules and regulations of appropriate Governmental Authorities, unless Tenant is otherwise exempt therefrom.

26.2 **Information and Reports.** Tenant will provide all information and reports pertinent to Landlord's Equal Employment, Anti-Discrimination and Affirmative Action requirements reasonably requested by Landlord and, subject to the rights of Subtenants and to the access requirements set forth in Section 2.4 above, Tenant will permit access to its facilities and any of its books, records, or other sources of information in Tenant's possession which may be reasonably determined by Landlord to relate to such requirements.

26.3 **Notices to Occupants, Contractors and Vendors.** Tenant will include the provisions of Section 26.1 in every contract or purchase order, and will require the inclusion of such provisions in every subcontract entered into by any of its contractors and vendors, so that such provisions will be binding upon each such contractor and vendor, as the case may be.

## ARTICLE 27

### **NOTICES**

27.1 **Notices.** All notices required or permitted hereunder shall be in writing and shall be deemed to have been properly given if (a) delivered in person or by electronic mail with originals to follow by

overnight courier; (b) delivered by with FedEx or other nationally recognized overnight mail or courier service, (c) sent by first class or certified mail, postage prepaid, addressed as follows, or to such other address as may thereafter be designated in writing by one Party to the other Party, or (d) delivered by email with a confirmatory copy sent via any method listed in (a)-(c):

If to Landlord:

Metropolitan Government of Nashville and Davidson County  
106 Metro Courthouse  
One Public Square  
Nashville, Tennessee 37219  
Attention: Mayor  
Email: [\_\_\_\_\_]

And to:

Metropolitan Government of Nashville and Davidson County  
108 Metro Courthouse  
One Public Square  
Nashville, Tennessee 37219  
Attention: Department of Law  
Email: tom.cross@nashville.gov

and if to Tenant:

[\_\_\_\_\_]  
c/o The Fallon Company LLC  
1222 Demonbreun Street, Suite 1210  
Nashville, Tennessee  
Attention: Benjamin Farrer  
Email: bfarrer@falloncompany.com

with copies to:

The Fallon Company LLC  
ONE Marina Park Drive, 14<sup>th</sup> Floor  
Boston, Massachusetts 02101  
Attention: Brian M. Awe  
Email: bawe@falloncompany.com

DLA Piper LLP (US)  
33 Arch Street, 26th Floor  
Boston, Massachusetts 02110  
Attention: John E. Rattigan, Jr., Esq.  
Oriana R. Montani, Esq.  
Email: john.rattigan@us.dlapiper.com  
oriana.montani@us.dlapiper.com

And to:

Bradley, Arant, Boult, Cummings LLP  
ONE 22 ONE  
1221 Broadway, Suite 2400  
Nashville, Tennessee 37203  
Attention: J. Thomas Trent, Jr. Esq.  
Jim Murphy, Esq.  
Email: ttrent@bradley.com  
jmurphy@bradley.com

Any notices or other communications under this Agreement must be in writing, and shall be deemed duly given or made at the time and on the date when received by e-mail transmittal of pdf files or similar electronic means or when personally delivered as shown on a receipt therefor (which shall include delivery by a nationally recognized overnight delivery service) to the address for each Party set forth above or when delivery is refused. Any Party, by written notice to the other in the manner herein provided, may designate an address different from that set forth below. Notwithstanding the foregoing to the contrary, any notice received by e-mail or other electronic means after 6:00 pm CT shall be deemed given or made on the next Business Day. Any notice to be given by any party hereto may be given by the counsel for such Party.

Either Landlord or Tenant may change its address for notices hereunder by giving written notice to the other in accordance with the provisions of this Article 27.

## ARTICLE 28

### MISCELLANEOUS

28.1 **Entire Agreement.** This Lease, and the Exhibits and addenda, if any, attached hereto and the documents signed and delivered by Landlord and Tenant in connection herewith and referred to herein (including but not limited to the Development Agreement and the Scope of Work Document) contain the entire agreement between the parties, and there are no agreements or representations between the parties except as expressed in this Lease and such other documents, which are intended to be an integration of all prior or contemporaneous promises, agreements, conditions, and undertakings between the parties hereto relating to the Premises.

28.2 **Modifications.** No subsequent change or addition to this Lease shall be binding unless in writing and signed by the parties hereto. No alleged or contended waiver of any of the provisions of this Lease shall be valid or effective unless in writing signed by the Party against whom it is sought to be enforced.

28.3 **Captions and Section Numbers.** Any article or section heading or the captions used throughout this Lease are for the purpose of convenience or reference only and the words contained therein shall in no way be held or deemed to define, limit, describe, explain, modify, amplify, or add to the interpretation, construction, or meaning of any provision of or the scope or intent of this Lease, nor in any way affect this Lease.

28.4 **Counterparts.** This Lease may be executed in several counterparts and the counterparts shall constitute but one and the same instrument. Delivery by electronic mail file attachment of any executed counterpart of this Lease will be deemed the equivalent of the delivery of the original executed instrument.



28.5 **Pronouns.** Wherever appropriate herein, the singular includes the plural and the plural includes the singular. When the context of this Lease requires, the neuter gender includes the masculine, the feminine, a partnership, limited liability company, corporation or joint venture, and the singular includes the plural.

28.6 **Severability.** The provisions of this Lease shall be deemed severable. If any part of this Lease shall be held unenforceable by any court of competent jurisdiction or in case any one or more of the provisions contained herein (except for the payment of rents) shall for any reason be held to be invalid, illegal or unenforceable in any respect, the remainder shall remain in full force and effect, and such unenforceable provision shall be reformed by such court so as to give maximum legal effect to the intention of the parties as expressed herein and/or this Lease shall be construed as if such invalid, illegal or unenforceable provision had not been contained herein.

28.7 **Consents and Approvals.** With respect to any matter which requires the approval of Landlord in accordance with the terms of this Lease (an “Approval Matter”), unless otherwise set forth herein, approval of such Approval Matter shall be undertaken by Appropriate Metro Staff and shall not be unreasonably withheld, delayed or conditioned. Any dispute between Tenant and Landlord regarding the reasonableness of Landlord’s withholding, delay or conditioning of its approval with respect to any Approval Matter shall be resolved pursuant to the procedure set forth in Article 25. In connection with any Approval Matter, unless a specific Landlord approval period with respect to such Approval Matter is expressly set forth in another provision of this Lease (in which case such other express provision shall govern and control with respect to Landlord’s time to approve such Approval Matter), Tenant shall submit to Landlord a written request for approval of such Approval Matter (an “Initial Approval Request”). If Landlord fails to disapprove of such Approval Matter within ten (10) days after Landlord’s receipt of such Initial Approval Request, Tenant shall be entitled to deliver to Landlord a second request for Landlord’s approval of such Approval Matter (a “Second Approval Request”), and Landlord’s reasonable approval shall be deemed to have been granted with respect to any Approval Matter if such Approval Matter is not disapproved in writing by Landlord within ten (10) days after Landlord’s receipt of a Second Approval Request.

(b) Any applicable deadlines to which Tenant is subject under this Agreement shall be deemed extended (i) by the period during which, pursuant to the procedure set forth in Article 25, the Senior Executives are discussing a Dispute with respect to any Approval Matter. and (ii) if Landlord is determined, pursuant to a final, unappealable order from a court of competent jurisdiction, to have unreasonably withheld, delayed or conditioned its approval, by the period of delay resulting from such unreasonable withholding, delaying or conditioning of such approval by Landlord. For the avoidance of doubt, the Parties hereto expressly agree that it shall be unreasonable for Landlord to withhold, delay or condition its approval with respect to any Approval Matter (x) that Landlord has previously approved or been deemed to have approved in accordance with the terms of this Agreement or (y) based solely on an element of such Approval Matter that Landlord has previously approved or been deemed to have approved in accordance with the terms of this Agreement.

(c) Each Initial Approval Request submitted pursuant to this Section 28.7 shall include the following language: “THIS IS AN INITIAL APPROVAL REQUEST FOR LANDLORD’S APPROVAL UNDER SECTION [ ] OF THE LEASE.” Any Second Approval Request submitted pursuant to this Section 28.7 shall include the following language: “THIS IS A SECOND APPROVAL REQUEST FOR LANDLORD’S APPROVAL UNDER SECTION [ ] OF THE LEASE. LANDLORD’S FAILURE TO RESPOND TO THIS SECOND APPROVAL REQUEST WITHIN TEN (10) DAYS SHALL BE DEEMED LANDLORD’S APPROVAL OF THE APPROVAL MATTER REFERENCED HEREIN.”

28.8 **Satisfaction of Requirements.** Wherever a requirement is imposed on any Party hereto, it shall be deemed that such Party shall be required to perform such requirement at its own sole cost and expense unless it is specifically otherwise provided herein. Each Party hereto agrees to act reasonably and in good faith with respect to the performance and fulfillment of the terms of each and every covenant and condition contained in this Lease, and with respect to the exercise of each and every right reserved herein.

28.9 **Waiver.** No failure by Landlord to insist upon the strict performance of any term, covenant, agreement, provision, condition, or limitation of this Lease to be kept, observed, or performed by Tenant and no failure by Landlord to exercise any right or remedy consequent upon a breach of any such term, covenant, agreement, provision, condition, or limitation of this Lease, shall constitute a waiver of any such breach or of any such term, covenant, agreement, provision, condition, or limitation. No waiver by Landlord of any violation or breach of any terms, provisions, or covenants herein contained shall be deemed or construed to constitute a waiver of any other or later violation or breach of the same or any other of the term, provisions, or covenants herein contained. The acceptance of any rent hereunder by landlord following the occurrence of any default by Tenant, whether or not known to Landlord, shall not be deemed a waiver of any such default.

28.10 **Relationship of Parties.** Nothing contained in this Lease or referred to herein shall be deemed or construed by the parties hereto or by any third party to create the relationship of principal and agent, partnership, joint venture, or any association between Landlord and Tenant, it being expressly understood and agreed that neither the provisions of this Lease nor any act of the parties hereto shall be deemed to create any relationship between Landlord and Tenant other than the relationship of landlord and tenant.

28.11 **Binding Effect.** The covenants and agreements contained in this Lease shall be binding upon and shall inure to the benefit of the parties hereto and their respective successors, and assigns (to the extent this Lease is assignable under the terms hereof).

28.12 **Independent Covenants.** This Lease shall be construed as though the covenants herein between Landlord and Tenant are independent and not dependent and Tenant hereby expressly waives the benefit of any statute to the contrary.

28.13 **Joint and Several Liability.** If either Tenant or Landlord comprises two or more Persons, the obligations imposed upon Tenant or Landlord (as the case may be) under this Lease shall be joint and several as between or among such Persons.

28.14 **Authority.** Tenant hereby represents and warrants to Landlord that each individual executing this Lease on behalf of Tenant is authorized to execute this Lease on its behalf. Landlord hereby represents and warrants to Tenant that each individual executing this Lease on behalf of Landlord is authorized to execute this Lease on its behalf.

28.15 **Brokerage.** Each of Tenant and Landlord represents to the other that it has not dealt with any broker in connection with this Lease and that, insofar as it knows, no broker has negotiated this Lease or is entitled to any fee or commission in connection herewith. Tenant agrees to indemnify, defend and hold Landlord and Landlord's agents harmless from and against any claims for a fee or commission made by any broker claiming to have acted by or on behalf of Tenant in connection with this Lease.

28.16 **Specific Performance of Landlord's and Tenant's Rights.** Landlord and Tenant shall each have the right to obtain specific performance of any and all of the covenants or obligations of the other Party under this Lease, and nothing contained herein shall be construed as or shall have the effect of

abridging such right. The provisions of this Section 28.16 shall survive any termination of this Lease with respect to the enforcement of the other provisions that survive the termination of this Lease.

28.17 **No Recording**. Each of Tenant and Landlord agrees not to record this Lease, provided that the parties shall be entitled to record the Memorandum of Lease in accordance with Section 2.5 hereof.

28.18 **Depositaries**. Any Depositary hereunder shall act pursuant to, and be indemnified in accordance with, such written instrument as the applicable Party and the Depositary shall mutually agree upon, execute, and deliver. Cash deposited with the Depositary shall be deposited in an interest bearing account with interest accruing thereon to accrue, at the election of Tenant (exercised prior to the deposit of funds with the Depositary), for the benefit of either Tenant or Landlord. Tenant shall indemnify Depositary for its actions under the direction of Tenant.

28.19 **Development Agreement**. Notwithstanding anything to the contrary set forth herein, Landlord and Tenant agree that (i) nothing set forth in this Lease is intended to increase, release, modify, limit or otherwise affect any of the rights, remedies, liabilities and/or obligations of Developer (or Tenant) or Owner (or Landlord) as set forth under the Development Agreement (other than satisfying the obligation to enter into this Lease) and (ii) in no event shall any breach or default by Developer or Owner under the Development Agreement constitute a breach or default under this Lease unless such breach or default under the Development Agreement is a breach or default of an obligation under the Development Agreement that is expressly assumed by Landlord or Tenant, as applicable, and which, pursuant to the terms hereof, constitutes independently a breach or default under this Lease.

28.20 **Governing Law; Venue**. This Lease shall be construed and enforced in accordance with the laws of the State of Tennessee. Each Party hereby irrevocably and unconditionally submits, for itself and its property, to the nonexclusive jurisdiction of any Tennessee state court or federal court of the United States of America sitting in Davidson County, Tennessee and any appellate court from any appeal thereof, in any action or proceeding arising out of or relating to this Lease or the transactions contemplated hereby.

28.21 **Rule Against Perpetuities**. If and to the extent that any of the covenants herein would otherwise be unlawful or void for violation of (a) the rule against perpetuities, (b) the rule restricting restraints on alienation, or (c) any other applicable statute or common law or rule analogous thereto or otherwise imposing limitations upon the time for which such covenants may be valid, then the provisions concerned shall continue and endure only until the expiration of a period of twenty-one (21) years after the death of the last to survive of the class of persons consisting of all of the lawful descendants of former U.S. President Barack Obama, living at the date of this Lease.

28.22 **No Merger**. There shall be no merger of the leasehold estate created by this Lease with the fee estate in the Premises by reason of the fact that the same person or entity may own or hold (a) the leasehold estate created by this Lease or any interest in such leasehold estate, and (b) the fee estate in the Premises or any interest in such fee estate; and no such merger shall occur unless and until all persons, including any Leasehold Mortgagee, having any interest in (i) the leasehold estate created by this Lease, or (ii) the fee estate in the Premises, shall join in a written instrument effecting such merger and shall duly record the same.

28.23 **Exculpation**.

(a) Tenant acknowledges and agrees that, except as set forth below, the liability of Landlord under this Lease shall be limited to its interest in the Premises, this Lease and any other assets, and any judgments rendered against Landlord shall be satisfied solely out of the Premises (including all insurance proceeds, condemnation proceeds, proceeds of sale or other

disposition of Landlord's interest, rents and other income receivable by Landlord with respect to the Premises) and such other assets. The provisions hereof shall inure to Landlord's successors and assigns. The foregoing shall not be deemed to limit Tenant's rights to obtain injunctive relief or specific performance. Nothing in this Section 28.23(a) shall limit the liability of Landlord, Owner or any of their respective Affiliates under the Development Agreement.

(b) Notwithstanding anything to the contrary contained in this Lease, including without limitation, either Party's equitable rights and remedies, except as otherwise provided in any separate guaranty, indemnification, or other separate instrument executed and delivered to either Party (including, without limitation, the Guaranty) and/or any the Parties' respective Affiliates in connection with this Lease or the Premises, no direct or indirect member, manager, partner, owner, shareholder, director, officer, employee, trustee, agent or representative in or of either Party or any of its Affiliates (each, a "Nonrecourse Party") shall have any personal liability in any manner or to any extent under this Lease, and neither Party nor any Person claiming by, through or under such Party shall have any recourse to any assets of a Nonrecourse Party. The limitation of liability provided in this Section 28.23(b) is in addition to, and not in limitation of, any limitation on liability applicable to a Nonrecourse Party provided by law or by this Lease or any other contract, agreement or instrument.

28.24 **Estoppel Certificate.** Recognizing that Landlord may find it necessary to establish to third parties, such as accountants, banks, potential or existing mortgagees, potential purchasers or the like, the then current status of performance hereunder, Tenant, within ten (10) Business Days after the written request of Landlord made from time to time, will furnish to Landlord, or any existing holder of any mortgage encumbering the Premises (each, a "**Landlord Interested Party**") a statement of the status of any matter pertaining to this Lease reasonably requested by such Landlord Interested Party, including acknowledgments that (or the extent to which) each Party is in compliance with its obligations under the terms of this Lease. Furthermore, recognizing that Tenant may find it necessary to establish to potential or existing lenders or subtenants, or to potential assignees or purchasers or the like, the then current status of performance hereunder, Landlord, within ten (10) Business Days after the request of Tenant made from time to time, will promptly furnish to Tenant, or any such lender, assignee, subtenant or purchaser (each, a "**Tenant Interested Party**") a statement of the status of any matter pertaining to this Lease reasonably requested by such Tenant Interested Party, including acknowledgments that (or the extent to which) each Party is in compliance with its obligations under the terms of this Lease. Any such status statement delivered by Tenant or Landlord pursuant to this Section shall operate as an estoppel and may be relied upon by Landlord, any Landlord Interested Party, Tenant or Tenant Interested Party, respectively.

28.25 **Confidentiality.**

(a) Neither Tenant, nor any of its employees, officers, directors, principals, agents, consultants or contractors, shall divulge or otherwise disclose (whether orally or by any other means) any part of Landlord's Confidential Information to any Person without Landlord's prior written consent; provided, that Tenant may without Landlord's consent share Landlord's Confidential Information with its Affiliates and those of any of their respective employees, officers, directors, members, managers, attorneys, principals, agents, accountants, consultants or contractors who need to receive such information in order to perform services or work relating to this Lease or the Project, or to prospective and actual partners, joint venturers, investors, environmental insurers, or lenders, prospective commercial tenants of the Project, or to other Persons who have executed confidentiality agreements with Landlord with respect to Landlord's Confidential Information; provided further, that Tenant requires compliance with and uses commercially reasonable efforts to enforce compliance by each such Person receiving Landlord's Confidential Information with the confidentiality requirements of this Section 28.25

and that Tenant informs each such person and entity receiving Landlord's Confidential Information of the confidential nature of such Landlord's Confidential Information and directs each such Person receiving Landlord's Confidential Information to treat Landlord's Confidential Information confidentially and not to use it other than in connection with the performance of services or work relating to this Lease or the Project or in the evaluation of this Lease or the Project for investment, purchase, sublease or financing. The term "Landlord's Confidential Information" as used herein shall mean all knowledge, information, data, materials, trade secrets and work product gained, obtained, derived, produced, generated or otherwise acquired by Tenant and/or any of its employees, officers, directors, principals, agents, consultants or contractors, with respect to this Lease, the Project or the Premises; Landlord and its other Affiliates; any of the Other Institutional Projects; any land owned by Landlord or its Affiliates; any real estate development plans of Owner; and any permitting processes and approvals related to, and the present or projected operations or affairs of, any of the foregoing. The term "Landlord's Confidential Information" shall not include information that (i) becomes generally available to the public but not due to actions or omissions of Tenant or any of its Representatives, (ii) information already lawfully in the possession of Tenant or its Representatives from a source not known by Tenant or its Representative to be bound by an obligation of confidentiality to Landlord or its Representatives with respect to such information, (iii) information that becomes available to Tenant or its Representatives from a source not known by Tenant or its Representative to be bound by an obligation of confidentiality to Landlord or its Representatives with respect to such information, and (iv) information independently developed by Tenant or its Representatives without reference to or use of the Confidential Information. Landlord reserves the right to retain and control all Landlord's Confidential Information relative to this Lease, the Project, the Premises; and any permitting processes and approvals related to, and the present or projected operations or affairs of, any of the foregoing (whether such constitutes Landlord's Confidential Information or not), including the timing of the release of any such information and the form and content of the same. Except as otherwise expressly provided in this Lease, Tenant shall promptly after the expiration of the Term or any termination of this Lease, destroy, or, promptly after written request by Landlord, return any and all written Landlord's Confidential Information, and all copies made of such items, to Landlord upon Landlord's request. Tenant agrees that Landlord's Confidential Information may be disclosed or used by Tenant only as provided above or otherwise authorized by Landlord. Tenant shall take such measures as are necessary to ensure that there shall be no disclosure of any of Landlord's Confidential Information to any unauthorized person by Tenant and/or any of its employees, officers, directors, members, managers, attorneys, principals, agents, accountants, consultants or contractors, as applicable. In the event that Tenant is involved in adversarial judicial proceedings, any disclosures made by Tenant to the extent necessary to comply with applicable Legal Requirements or in connection with its defense in such judicial proceeding shall not be considered a disclosure in violation of this provision, provided that Tenant complies with the provisions of Section 28.25(c) below. Without limiting the generality of the foregoing, Tenant agrees that, prior to disclosing to, or discussing with, whether orally or by any other means, any other Person, any matter relative to this Lease, the Project or the Premises that would require any governmental or quasi-governmental discretionary approval (whether such matter involves the disclosure of Landlord's Confidential Information or not) in order to implement or accomplish, Tenant shall first notify Landlord of such proposed disclosure or discussion, and consult with Landlord regarding the same, and if such matter involves the disclosure of any Landlord's Confidential Information, comply with the provisions of this Section 28.25 with respect thereto.

(b) Landlord and Tenant have agreed upon the following protocol to be followed by Tenant with respect to Environmental Due Diligence Information that may be provided to

Subtenants and prospective Subtenants: Tenant may inform Subtenants and prospective Subtenants of the Premises: (1) that the Premises and adjacent parcels are the subject of past releases of Hazardous Materials, including releases identified by the Environmental Report; (2) of the status of ongoing or completed assessment and remediation activities at the Premises; and (3) that ongoing or completed assessment and remediation activities are described in documents related to the Premises that are publicly available. If a Subtenant or prospective Subtenant shall request environmental information about the Premises that is not publicly available, but that Tenant proposes to disclose to such Subtenant or prospective Subtenant, Tenant shall submit such request in writing to Landlord for Landlord's approval, which approval shall not be unreasonably withheld, delayed or conditioned. Landlord shall issue a written response to Tenant's written request for approval within seven (7) Business Days after receiving the same from Tenant.

(c) Except as otherwise required law, including (without limitation) the Tennessee Public Records Act, neither Landlord nor any of its employees, officers, directors, principals, agents, consultants or contractors, shall divulge shall divulge or otherwise disclose (whether orally or by any other means) any part of Tenant's Confidential Information (as hereinafter defined) to any Person without Tenant's prior written consent; provided, that Landlord may without Tenant's consent share Tenant's Confidential Information with its Affiliates and those of any of their respective employees, officers, directors, members, managers, attorneys, principals, agents, accountants, consultants or contractors who need to receive such information in order to perform services or work relating to this Lease or the Project, or to prospective or actual partners, investors, joint venturers, environmental insurers, purchasers or lenders, or to other Persons who have executed confidentiality agreements with Tenant with respect to Tenant's Confidential Information; provided further, that Landlord requires compliance and uses commercially reasonable efforts to enforce compliance by each such Person receiving Tenant's Confidential Information with the confidentiality requirements of this Section 28.25(c) and that Landlord informs each such Person receiving Tenant's Confidential Information of the confidential nature of such Tenant's Confidential Information and directs each such Person receiving Tenant's Confidential Information to treat Tenant's Confidential Information confidentially and not to use it other than in connection with the performance of services or work relating to this Lease or the Project or in the evaluation of this Lease or the Project for investment, purchase or financing. The term "Tenant's Confidential Information" as used herein shall mean all knowledge, information, data, materials, trade secrets and work product gained, obtained, derived, produced, generated or otherwise acquired by Landlord and/or any of its employees, officers, directors, principals, agents, consultants or contractors, with respect to the economic terms of this Lease or non-public or proprietary information concerning the Project, Tenant or any of its Affiliates, any land owned by Tenant or any of its Affiliates, any real estate development plans of Tenant or any of its Affiliates, and any permitting processes and approvals related to, and the present or projected operations or affairs of, any of the foregoing. The term "Tenant's Confidential Information" shall not include information that (i) becomes generally available to the public but not due to actions or omissions of Landlord or any of its Representatives, (ii) information already lawfully in the possession of Landlord or its Representatives from a source not known by Landlord or its Representative to be bound by an obligation of confidentiality to Tenant or its Representatives with respect to such information, (iii) information that becomes available to Landlord or its Representatives from a source not known by Landlord or its Representative to be bound by an obligation of confidentiality to Tenant or its Representatives with respect to such information, and (iv) information independently developed by Landlord or its Representatives without reference to or use of the Confidential Information. Tenant reserves the right to retain and control all Tenant's Confidential Information relative to this Lease, the Project, the Premises, Tenant or any of its

Affiliates, any land owned by Tenant or its Affiliates, any real estate development plans of Tenant or any of its affiliates, and any permitting processes and approvals related to, and the present or projected operations or affairs of, any of the foregoing (whether such constitutes Tenant's Confidential Information or not), including the timing of the release of any such information and the form and content of the same. Except as otherwise expressly provided in this Lease or as otherwise required by applicable law, including (without limitation) the Tennessee Public Records Act, Landlord shall promptly after the expiration of the Term or any termination of this Lease, destroy or, promptly after written request by Tenant, return any and all written Tenant's Confidential Information, and all copies made of such items, to Tenant upon Tenant's request. Landlord agrees that Tenant's Confidential Information may be disclosed or used by Landlord only as provided above or otherwise authorized by Tenant. Landlord shall take such measures as are necessary to ensure that there shall be no disclosure of any of Tenant's Confidential Information to any unauthorized Person by Landlord, any of its Affiliates and/or any of their respective employees, officers, directors, members, managers, attorneys, principals, agents, accountants, consultants or contractors, as applicable. In the event that Landlord is involved in adversarial judicial proceedings, any disclosures made by Landlord to the extent necessary to comply with applicable Legal Requirements or in connection with its defense in such judicial proceeding shall not be considered a disclosure in violation of this provision, provided that Landlord complies with the provisions of Section 28.25(d) below. Without limiting the generality of the foregoing, Landlord agrees that, prior to disclosing to, or discussing with, whether orally or by any other means, any other Person any matter relative to this Lease, the Project or the Premises that would require any governmental or quasi-governmental approval (whether such matter involves the disclosure of Tenant's Confidential Information or not) in order to implement or accomplish, Landlord shall first notify Tenant of such proposed disclosure or discussion, and consult with Tenant regarding the same, and if such matter involves the disclosure of any Tenant's Confidential Information, comply with the provisions of this Section 28.25 with respect thereto. Notwithstanding anything to the contrary herein, to the extent that any of Tenant's Confidential Information could become public information by virtue of delivering such information to Landlord, Tenant shall be entitled to provide such information to Landlord by (a) making such information available to Landlord for review, (b) providing such information to Landlord via an online repository or share file, or (c) any other reasonable means of providing information that could be reasonably anticipated to prevent the information from becoming publicly available pursuant to the Tennessee Public Records Act or any other applicable Legal Requirements, but Landlord makes (and shall not be deemed to have made) any representation or warranty that such actions will prevent such information from becoming publicly available.

(d) To the extent permitted by applicable law, Tenant shall promptly notify Landlord of any court order, subpoena or similar legal process requiring disclosure of any Landlord's Confidential Information promptly after Tenant obtains knowledge of the same, and shall, subject to applicable Legal Requirements, reasonably cooperate (at Landlord's sole expense) with legal counsel for Landlord in the appeal or challenge of any such order, subpoena or similar legal process. Tenant may disclose Landlord's Confidential Information required to be disclosed pursuant to court order, subpoena or similar legal process, only after Tenant, as receiver, has used commercially reasonable efforts to obtain a protective order or other reliable assurance that confidential treatment will be accorded to Landlord's Confidential Information required to be disclosed.

(e) To the extent permitted by applicable law, Landlord shall promptly notify Tenant of any court order, subpoena or similar legal process requiring disclosure of any Tenant's Confidential Information promptly after Landlord obtains knowledge of the same, and shall,

subject to applicable Legal Requirements, reasonably cooperate (at Tenant's sole expense) with legal counsel for Tenant in the appeal or challenge of any such order, subpoena or similar legal process. Landlord may disclose Tenant's Confidential Information required to be disclosed pursuant to court order, subpoena or similar legal process, only after Landlord, as receiver, has used commercially reasonable efforts to obtain a protective order or other reliable assurance that confidential treatment will be accorded to Tenant's Confidential Information required to be disclosed.

(f) Each Party acknowledges that money damages may not be a sufficient remedy for any violation of the terms of this Section 28.25 and accordingly a non-breaching Party will be entitled to specific performance and injunctive relief as remedies for any violation of this Section 28.25 by the other Party. These remedies will not be exclusive remedies but will be in addition to all other remedies available to such non-breaching Party at law or equity.

(g) Tenant and Landlord acknowledge and agree that, as between Tenant and Landlord, the terms of this Section 28.25 supersede the terms of any non-disclosure, confidentiality or similar agreement executed by Landlord, or any Affiliate of Landlord, and Tenant, or any Affiliate of Tenant, prior to the Lease Commencement Date.

(h) Nothing herein shall prohibit Tenant from (i) expressly referring to this Lease in any sublease, any Leasehold Mortgage (or any other financing documents relating to any loan secured thereby) or any financing documents secured by any Mezzanine Financing Security or any documents relating to the sale or assignment of Tenant's leasehold interest under this Lease or from providing a copy of this Lease to any Subtenant, any Leasehold Mortgagee, any Mezzanine Lender or any prospective Subtenant, Leasehold Mortgagee, Mezzanine Lender, purchaser or assignee; provided, however, that any such copy of this Lease that is provided to any such Subtenant or prospective Subtenant shall be redacted to remove all economic terms hereof, including all provisions dealing with the payment of Rent; and provided further that the provisions of Section 28.25(a) shall apply to Tenant's delivery of the Lease pursuant to this Section 28.25(h) and Tenant shall remain bound by all of its obligations with respect to disclosure of Landlord's Confidential Information set forth in Section 28.25(a).

(i) The provisions of this Section 28.25 shall survive for a period of four (4) years following any termination of this Lease.

**[Remainder of Page Intentionally Left Blank]**



IN WITNESS WHEREOF, the parties hereto have executed this Ground Lease as an instrument under seal as of the date first set forth above.

LANDLORD: THE METROPOLITAN GOVERNMENT OF  
NASHVILLE AND DAVIDSON COUNTY

By: \_\_\_\_\_  
Name:  
Title: Metropolitan Mayor

ATTEST:

By: \_\_\_\_\_  
Metropolitan Clerk

APPROVED AS TO FORM AND LEGALITY:

\_\_\_\_\_  
Director of Law

TENANT: [\_\_\_\_\_] , a [\_\_\_\_\_]   
By: \_\_\_\_\_  
Name:  
Title:

**EXHIBIT A-1**

Description of the Land

[*insert legal description*]

**EXHIBIT A-2**

Premises Plan

## **EXHIBIT B**

### Description of the Campus

#### Parcel Numbers

09302006800  
08215003000  
09303002200  
09302008700  
09303006600  
09303017400  
09303015300  
09307001000  
09303017100  
09303011500  
09307004600  
09307005100

Such parcels being lots 2, 3, 4, 5, 8, 9, 10, 11, and 12 on the Phase Two Subdivision Plat, Tennessee NFL Stadium, East Bank Redevelopment Plan, of record in Book 9700, Pages 986 and 987, R.O.D.C., and lots 13 and 14A on the Unified Plat of Subdivision of Lots 6, 13 & 14 of the Phase Two Subdivision Plat, Tennessee NFL Stadium, East Bank Redevelopment Plan, of record at Instrument No. 20100929-0077565, R.O.D.C., and lot 15 on the Resubdivision to Phase 2 Lot 15, Tennessee NFL Stadium, East Bank Redevelopment Plan, of record at Instrument No. 20100924-0076276, R.O.D.C., and further having been conveyed to Metro by deed of record at Instrument No. 20230901-0068581, R.O.D.C.

**EXHIBIT C**

Form of Memorandum of Lease

[See Attached]

**EXHIBIT D-1**

Approved Development Master Plan

[See Attached]

**EXHIBIT D-2**

Scope of Work Document

[See Attached]

[Exhibit D-2 - 1]

**EXHIBIT E-1**

Final Plans and Specifications

[See Attached]



**EXHIBIT E-2**

Obtained Project Approvals

[See Attached]

**EXHIBIT F**

Approved Project Budget

[See Attached]

[Exhibit F - 1]

**EXHIBIT G**

Anticipated Project Schedule

[See Attached]

**EXHIBIT H**

Construction Management Plan

[See Attached]

[Exhibit H - 1]

**EXHIBIT I**

SMWBE Plan

[See Attached]

## EXHIBIT J

### Amended and Restated Provisions Upon Certain Landlord Transfers

- a. Landlord's rights to access the Premises – 2.4 – *to remove Landlord's right to access the Premises.*
- b. Architect, Landscape Architect, or GC for any Alterations – 4.4(d) – *to remove Landlord's approval over design professionals for Material Alterations.*
- c. Material Alterations – 4.8(a) – *to remove landlord's approval right over Material Alterations.*
- d. Assignment and Transfer – 12.1 - *to (i) remove Landlord's approval rights over transfers other than to Prohibited Persons and (ii) amend the definition of Prohibited Persons to delete items viii, ix, and x in such definition.*
- e. Sublease of Substantially all of the Premises – 14.1 – *to remove Landlord's approval rights over subtenants other than for Prohibited Persons.*
- f. Managing Agent of a New Tenant (by virtue of foreclosure or deed in lieu) that Does Not Have Management Experience – 13.6(d) – *to remove landlord's approval rights over manager in event of a foreclosure/deed in lieu.*
- g. Functionally obsolete Improvements – 17.1(e) – *to delete this provision.*

**SCHEDULE 4.7**

**Construction Insurance**

**SCHEDULE 9.1**

Insurance Requirements

[Schedule 9.1 - 1]



## **SCHEDULE 25.3**

### Senior Executives

#### Owner Senior Executives

1. The Mayor of the Metropolitan Government of Nashville and Davidson County, Tennessee or any designee of the Mayor so long as such designee either has the title of Director or otherwise reports directly to the Mayor; and
2. Following an assignment of this Agreement to the East Bank Authority, the Chief Executive Officer of the East Bank Authority
3. Following an assignment of this Agreement to any non-governmental or quasi-governmental entity in accordance with the terms hereof, any Chairman, Chief Executive Officer, President, Chief Operating Officer, or similar officer with decision making authority.

#### Developer Senior Executive

1. Any Chairman, Chief Executive Officer, President, Chief Operating Officer, or similar officer with decision making authority.

**Exhibit C-2**

Form of Memorandum of Ground Lease

**MEMORANDUM OF GROUND LEASE**

THIS MEMORANDUM OF GROUND LEASE, is made and entered into this \_\_\_\_ day of \_\_\_\_\_, \_\_\_\_\_, by and between \_\_\_\_\_, a \_\_\_\_\_ (the "Landlord"), and \_\_\_\_\_, a \_\_\_\_\_ (the "Tenant").

**W I T N E S S E T H:**

The Landlord, for and in consideration of the rents to be paid and of the other covenants and agreements to be kept and performed by the Tenant, does hereby demise and lease to the Tenant, and the Tenant does hereby take and lease from the Landlord, subject to Permitted Encumbrances and terms and conditions of the Lease (as defined below), those certain pieces or parcels of land, situated, lying and being in Davidson County, Tennessee, being more particularly described in **Exhibit A**, attached hereto and incorporated herein by this reference (the "Demised Premises");

TO HAVE AND TO HOLD the same subject to all the provisions and conditions contained in that certain Ground Lease Agreement, dated as of [\_\_\_\_\_], by and between Landlord and Tenant (the "Lease"), which Lease provides, among other things, as follows.

1. The rate of rental and all terms of Tenant's occupancy of the Demised Premises are set forth in the Lease.

2. The term of the Lease shall commence on the date hereof and shall terminate on [\_\_\_\_\_], unless extended or earlier terminated pursuant to the provisions of the Lease.

3. All terms and conditions of the Lease are hereby incorporated herein by reference as if fully set forth herein. The sole purpose of this instrument is to give notice of said Lease, and this instrument does not amend, modify, supplement, or change the terms of the Lease in any respect whatsoever. The terms and conditions contained in the Lease shall, at all times and in all respects, govern and control.

[Remainder of Page Intentionally Blank; Signature Pages Follow]

IN WITNESS WHEREOF, the parties have hereunto set their hands and seals as of the day and date first above written.

ATTEST:

\_\_\_\_\_  
Name: \_\_\_\_\_  
Title: \_\_\_\_\_

\_\_\_\_\_  
By: \_\_\_\_\_  
Name: \_\_\_\_\_  
Title: \_\_\_\_\_

\_\_\_\_\_  
By: \_\_\_\_\_  
Name: \_\_\_\_\_  
Title: \_\_\_\_\_

STATE OF

COUNTY OF

Personally appeared before me, \_\_\_\_\_, Notary Public, \_\_\_\_\_, with whom I am personally acquainted (or proved to me on the basis of satisfactory evidence), and who acknowledged that he/she executed the foregoing instrument for the purposes therein contained and who further acknowledged that he/she is the \_\_\_\_\_, of \_\_\_\_\_, a \_\_\_\_\_, the within named bargainer and that he/she is authorized to execute this instrument on behalf of said corporation.

WITNESS my hand, at office, this \_\_\_\_ day of \_\_\_\_\_, \_\_\_\_\_.

\_\_\_\_\_  
Notary Public

My Commission Expires: \_\_\_\_\_

STATE OF

COUNTY OF

Personally appeared before me, \_\_\_\_\_, Notary Public, \_\_\_\_\_, with whom I am personally acquainted (or proved to me on the basis of satisfactory evidence), and who acknowledged that he/she executed the foregoing instrument for the purposes therein contained and who further acknowledged that he/she is the \_\_\_\_\_, of \_\_\_\_\_, a \_\_\_\_\_, the within named bargainer and that he/she is authorized to execute this instrument on behalf of said corporation.

WITNESS my hand, at office, this \_\_\_\_ day of \_\_\_\_\_, \_\_\_\_\_.

\_\_\_\_\_  
Notary Public

My Commission Expires: \_\_\_\_\_

STATE OF \_\_\_\_\_

COUNTY OF \_\_\_\_\_

Personally appeared before me, \_\_\_\_\_, Notary Public,  
\_\_\_\_\_, with whom I am personally acquainted (or proved to me on the  
basis of satisfactory evidence), and who acknowledged that he/she executed the foregoing  
instrument for the purposes therein contained and who further acknowledged that he is the  
\_\_\_\_\_ of \_\_\_\_\_, a \_\_\_\_\_,  
and that he is authorized to execute this instrument as on behalf of said limited liability company  
as such \_\_\_\_\_.

WITNESS my hand, at office, this \_\_\_\_ day of \_\_\_\_\_, \_\_\_\_\_.

\_\_\_\_\_  
Notary Public

\_\_\_\_\_  
My Commission Expires

## EXHIBIT D

### SCOPE OF WORK DOCUMENT

The provisions of this Exhibit D (this "Scope of Work Document") are intended to supplement the provisions of the Master Development Agreement to which it is annexed (the "Master Development Agreement"). Unless otherwise expressly provided in this Scope of Work Document, all references herein to the Master Development Agreement shall be deemed to include all Schedules and Exhibits annexed thereto. Capitalized terms used in this Scope of Work Document, but not defined herein, have the respective meanings assigned to those terms in the Development Agreement (as defined in the Master Development Agreement).

This Scope of Work Document sets forth the Parties' respective obligations concerning the responsibilities, work, and cost allocation associated with the construction of the physical elements of the Project described on the attached chart below (each, a "Project Element"). In connection with any utilities to be constructed by any party, such utilities will be constructed with required capacity to service East Bank Project. Owner will be obligated to ensure that there are or will be as needed by Developer, sufficient utilities in the roads connecting to any road within the IDA Land to be constructed by Developer or adjacent to the IDA Land sufficient to permit Developer to tie into such utilities without any obligation to construct utilities infrastructure that is not expressly listed to be the obligation of Developer or any third party other than Owner on the attached chart.

This Scope of Work is focused on the work at hand to meet the development requirements of the initial Master Development Agreement Parcels of the Project. The document also describes specific scope items that carry forward into future Master Development Agreement Parcels with a description of the anticipated allocation of responsibilities and costs. Based on Owner's and Developer's current knowledge as of the Effective Date of the Development Agreement of Phases B and C, these Scope of Work assumptions will be reviewed and supplemented in accordance with the Master Development Agreement.

Exhibits 1-5 are in draft form, and do not reflect final alignments.

# East Bank

## Draft - For Discussion Only

23-Feb-24

Item	Description	Funding Responsibility	Construction Responsibility	Affected Parcel	Exhibit
<b>Titans' (Infrastructure Required to Open the New Stadium)</b>					
<b>Item</b>					
Water	From Water Main Exhibit (Barge 12/21/23)	Titans	Titans	IDA	Exhibit 1
Sanitary Sewer	From Sanitary Sewer Exhibit (Barge 12/21/23)	Titans	Titans	IDA	Exhibit 2
Storm	From Storm Exhibit (Barge 12/21/23)	Titans	Titans	IDA	Exhibit 3
Gas	From Gas Exhibit (Barge 12/21/23)	Titans	Titans	IDA	Exhibit 4
Power/Telecom	From Power/Telecom Exhibit (Barge 12/21/23)	Titans	Titans	IDA	Exhibit 5
South 2nd Street Plaza	Adjacent to Stadium. Pavers, trees, street furniture, lights, infrastructure and power for community events. Titans responsible for stairs, ramp, stage, and monitors.	Titans	Titans	C	Exhibit 6
South 2nd Street	From JRP to Sylvan	Titans/Metro	Titans	B,C,D	Exhibit 7
Interstate Drive	From JRP to Shelby	Titans	Titans	B,C	Exhibit 8
<b>Fallon IDA (Infrastructure Required for Fallon and Related Development)</b>					
<b>Item</b>					
East Bank Boulevard	From Victory to KVB, adjacent to Parcel D, E1 and F	Fallon*	Fallon	D,E1,F	Exhibit 9
Parking Garage on Parcel C	Metro Parking Spaces on Parcel C, if any	Metro	Fallon	C	In Design Stage
Victory Avenue	From 2nd St. to Waterside Dr.	TPAC	TPAC	D,E	Exhibit 10
Waterside Drive - Parcel E	From Victory to Ped Bridge, Adjacent to Parcel E	TPAC	TPAC	E	Exhibit 11
MCM on Parcel E	Demo existing bridge structure from main span to EBB. New East-west temporary structure touching down in Parcel F.	TPAC	TPAC	E,F	Exhibit 12
Waterside Drive - Parcel F	From MCM to KVB (Adjacent to Area F)	Fallon**	Fallon	F	Exhibit 13
MCM Across East Bank Blvd.	Ped bridge to span East Bank Blvd.	Metro	Fallon	D,E1	Exhibit 14
Relocation of Colonial Pipeline	Removal and relocation out of parcel F	Metro	Metro	F	In Design Stage
MCM extension on Area D,E1	Ped bridge on structure, stairs, ramp, and 2 elevators on Parcel D. Extension of already in place MCM across parcel F to EBB.***	Fallon*	Fallon	D,E1	Exhibit 15
Sylvan	2nd St. to Interstate Dr. Extension	Fallon	Fallon	G	Exhibit 16
<b>Balance of East Bank Campus (Central Waterfront Area)</b>					
<b>Item</b>					
East Bank Blvd	JRP to Victory	TBD	TBD	A,B	Exhibit 17
Woodland	From East Bank to Interstate Dr.	TBD	TBD	B	Exhibit 18
James Robertson Pkwy lowered to grade to intersect with East Bank Blvd. then extended to Interstate drive	From main span to Interstate Dr.	TBD	TBD	A,B	Exhibit 19
Russel St.	Reconstruction from 2nd to Waterside Dr.	TBD	TBD	Future Parcels (fp)	Exhibit 20
Waterfront Greenway and East Bank Park	Linear park space from JRB to KVB and central park West of Titans Stadium	TBD	TBD	E,F,fp	Exhibit 22

Shelby	East Bank to Interstate Drive	TBD	TBD	C,D,F,G	Exhibit 23
<p>*Metro can accelerate upon provision of funding, with reimbursement to be made by Fallon at closing of relevant parcels.</p> <p>**Fallon option to not build until removal of CSX and connection point on south side of KVB</p> <p>***Pedestrian Bridge Extension will provide for continuous bicycle access on parcel D that does not require riders to dismount, unless the parties identify and agree to an alternative solution that provides for continuous bicycle access across the pedestrian bridge to and through the East Bank that does not require riders to dismount.</p>					



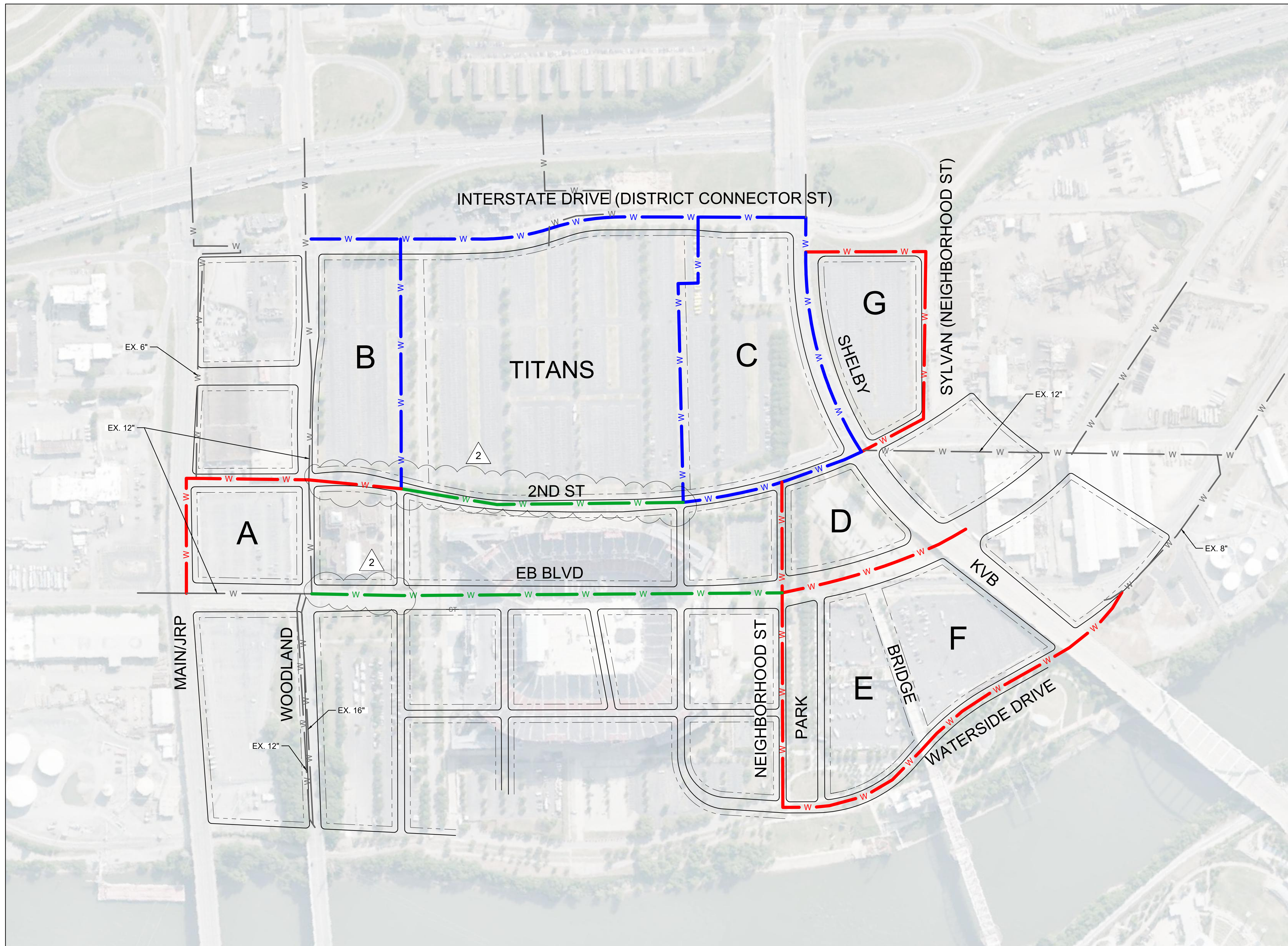

**LEGEND**

- W — TITANS
- W — PROPOSED
- W — FUTURE
- W — EXISTING

**WATER MAIN**

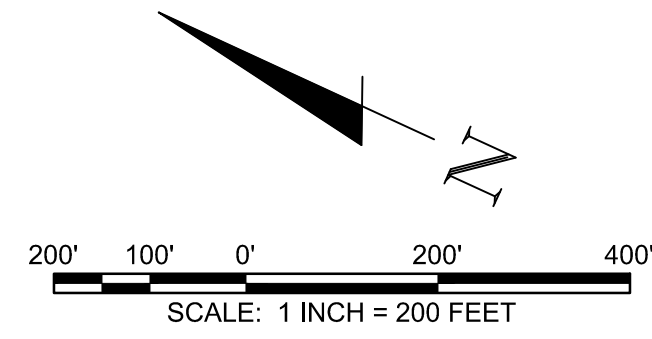

USER: JMBROYD  
 FILE: F:\38\3800\38000004\_CAD\CIVIL\PLT\CS.00.dwg  
 SAVED: 12/1/2023  
 PLOTTED: 12/1/2023

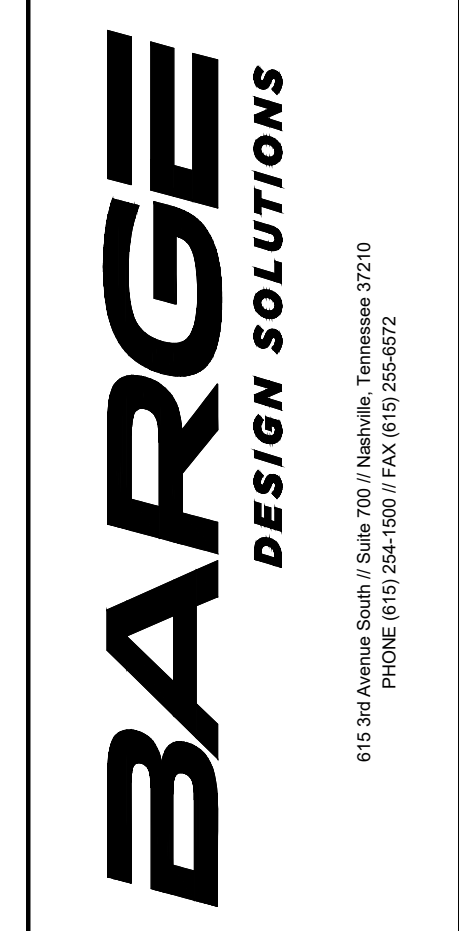

615 3rd Avenue South / Suite 700 / Nashville, Tennessee 37210  
 PHONE (615) 254-1588 / FAX (615) 254-6272

PRELIMINARY  
 NOT FOR  
 CONSTRUCTION  
 DATE \_\_\_\_\_

**WATER MAIN PLAN**  
**THE FALLON COMPANY**  
**EAST BANK IDA**  
 NASHVILLE, TN

REVISION INFORMATION	
REV.	DESCRIPTION

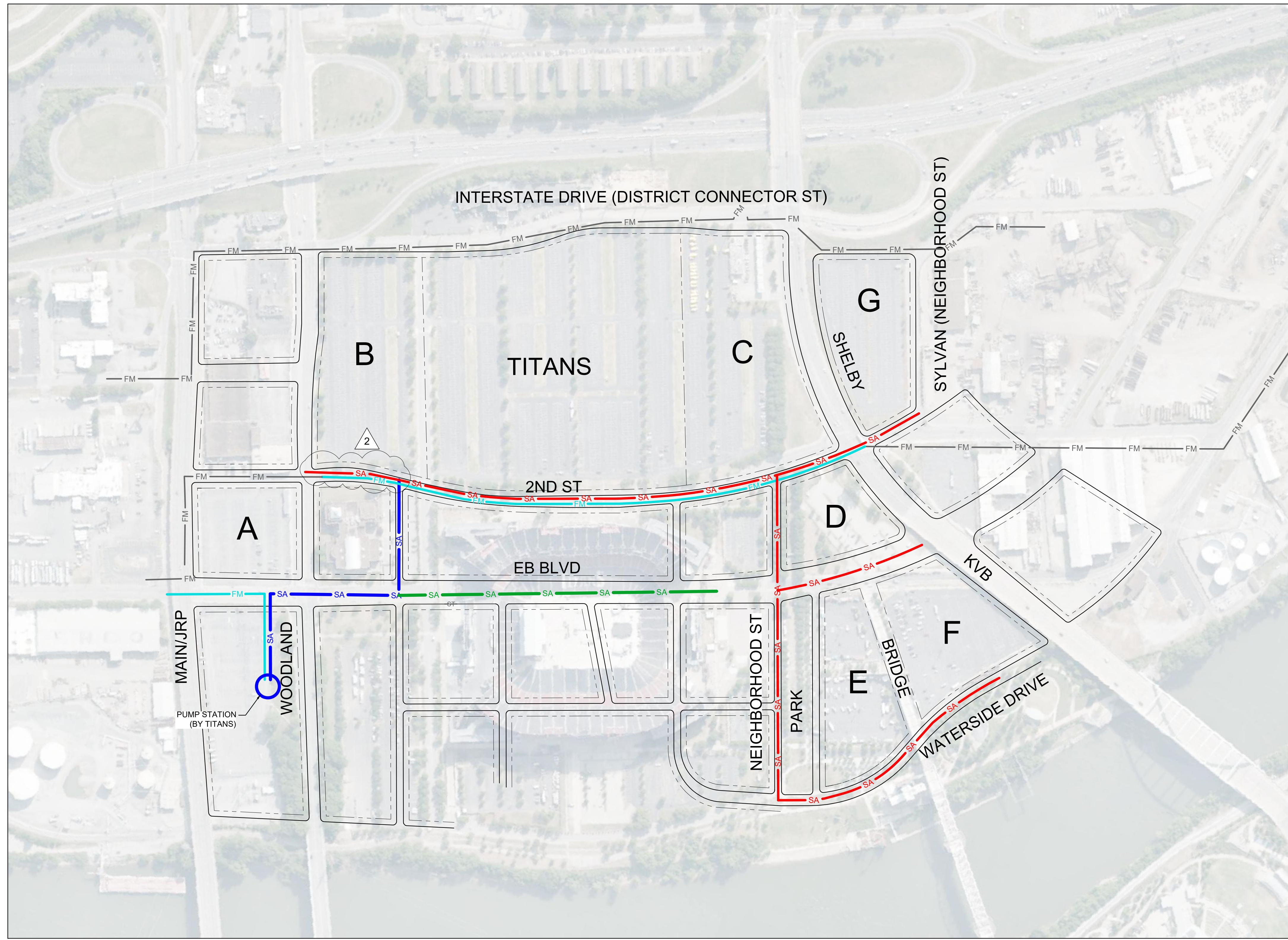

LEGEND

- SA — TITANS
- FM — TITANS FORCE MAIN
- SA — PROPOSED
- SA — FUTURE
- FM — EXISTING FORCE MAIN

NOTE

1. TITANS TO RELOCATE FORCE MAIN IN 2ND ST.
2. SEWER TO BE BUILT WITH EB BLVD TO SERVE PARCELS OUTSIDE OF THE IDA

615 3rd Avenue South / Suite 700 / Nashville, Tennessee 37210  
PHONE: (615) 254-1000 / FAX: (615) 254-0072

PRELIMINARY  
NOT FOR  
CONSTRUCTION

SANITARY SEWER PLAN

THE FALLON COMPANY  
EAST BANK IDA  
NASHVILLE, TN

SANITARY SEWER

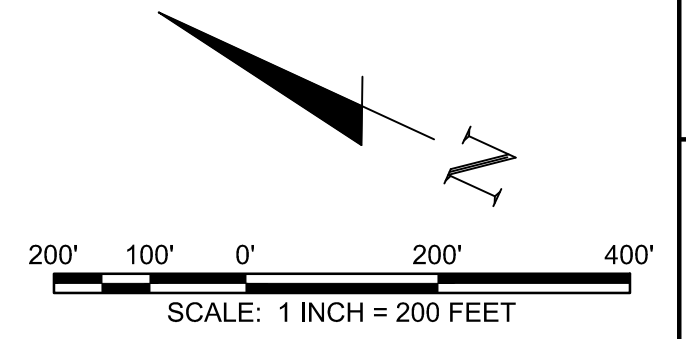

USER: JMBROYD  
FILE: F:\388\38800\388000004\_CAD\CIVIL\PLT\CS3.00.dwg  
SAVED: 12/1/2023  
PLOTTED: 12/1/2023

REV.	DR.	CHK.	DATE	DESCRIPTION

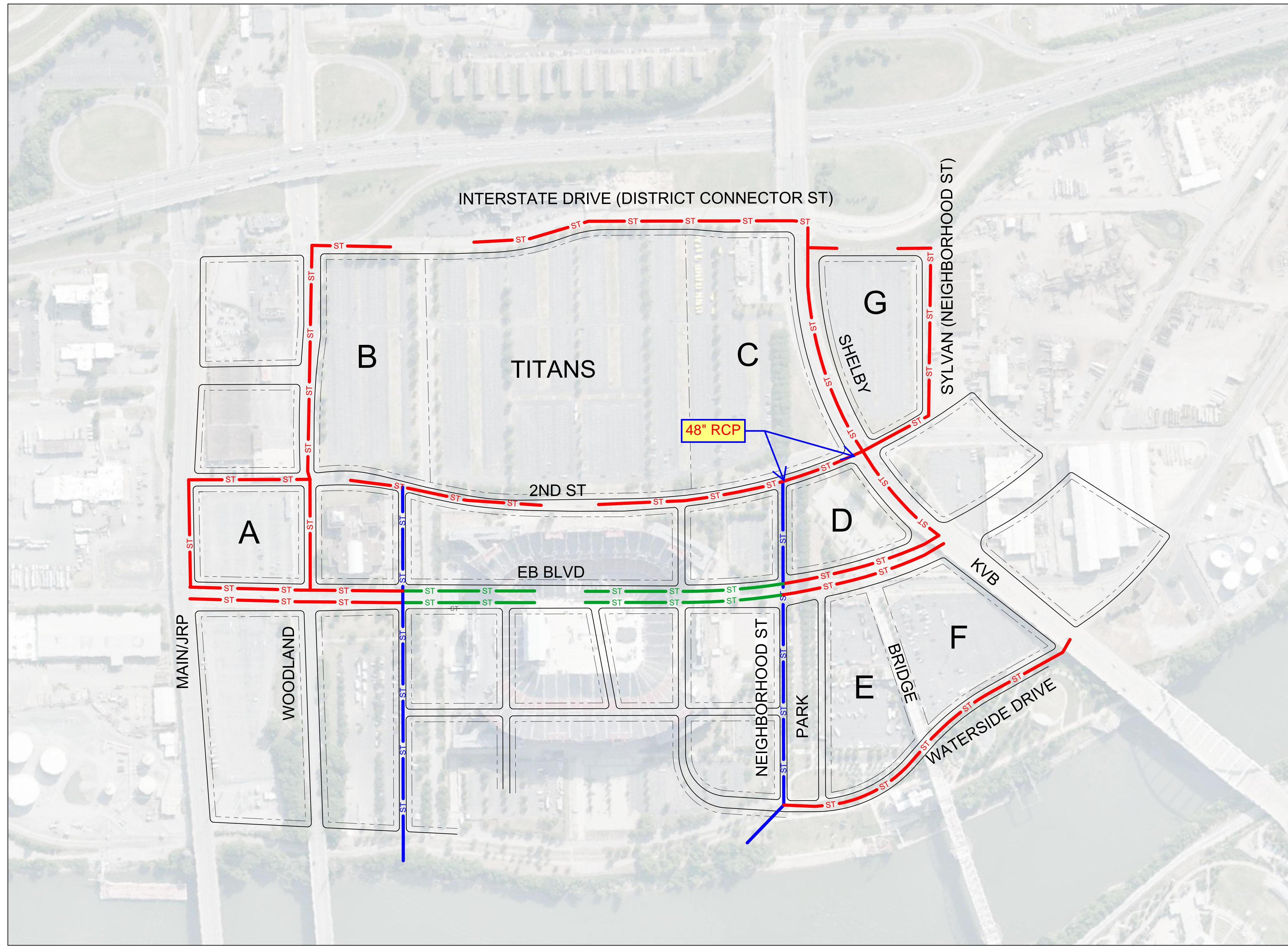

**STORM**

**LEGEND**

<span style="color: blue;">—</span> ST	TITANS
<span style="color: red;">—</span> ST	PROPOSED
<span style="color: green;">—</span> ST	FUTURE

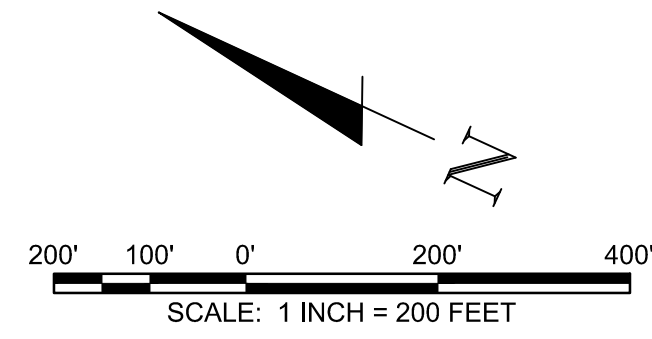

PRELIMINARY  
NOT FOR  
CONSTRUCTION

DATE \_\_\_\_\_

**STORM PLAN**

**THE FALLON COMPANY**  
**EAST BANK IDA**  
NASHVILLE, TN

REV.	DR.	CHK.	DATE	DESCRIPTION

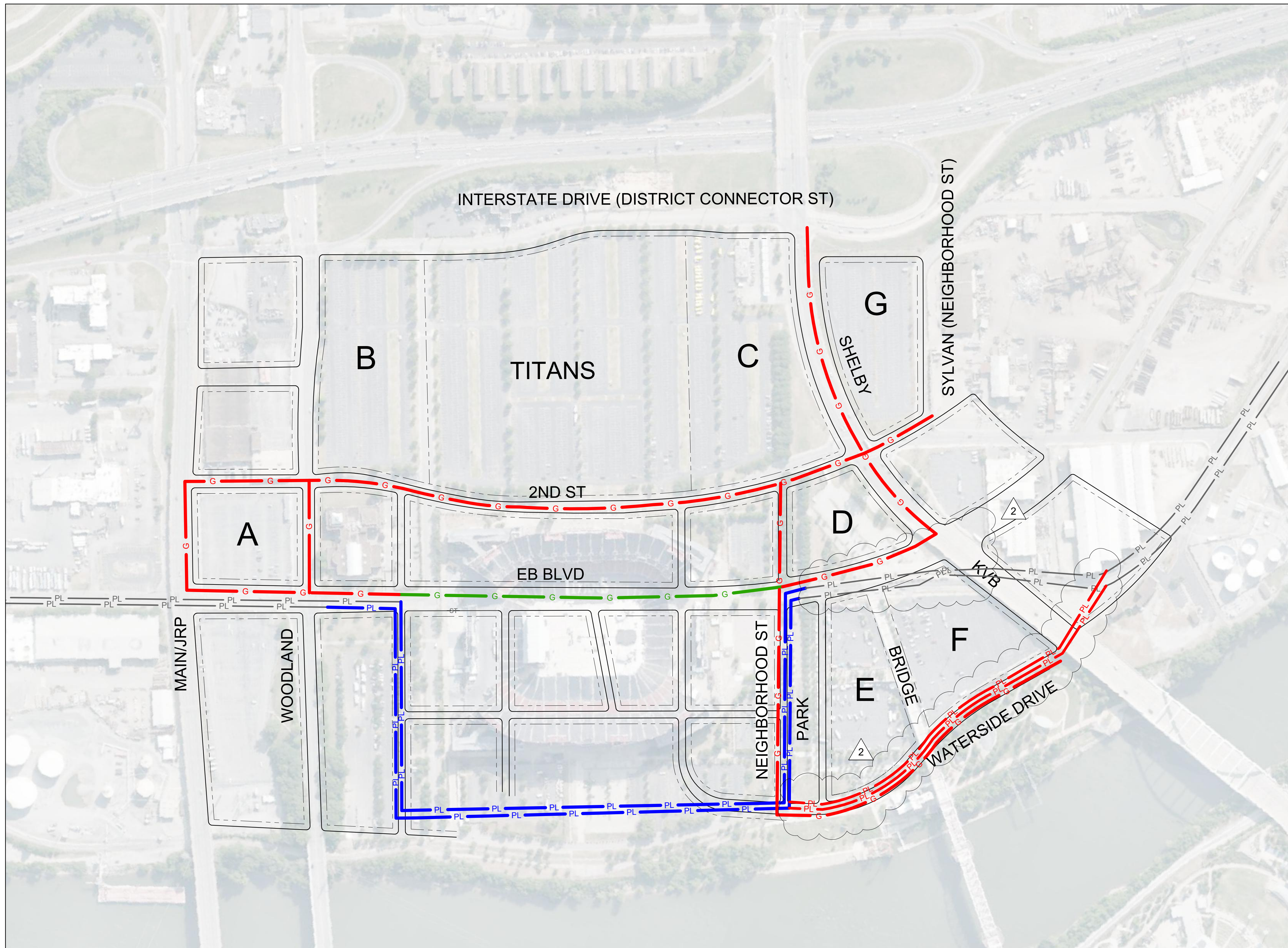

**LEGEND**

- G — TITANS
- PL — TITANS COLONIAL PIPELINE RELOCATION
- G — PROPOSED
- PL — PROPOSED COLONIAL PIPELINE RELOCATION
- G — FUTURE
- PL — EXISTING COLONIAL PIPELINE

PRELIMINARY  
NOT FOR  
CONSTRUCTION

DATE \_\_\_\_\_

**GAS PLAN**

**THE FALLON COMPANY  
EAST BANK IDA**  
NASHVILLE, TN

**REVISION INFORMATION**

REV.	DR.	CHK.	DATE	DESCRIPTION

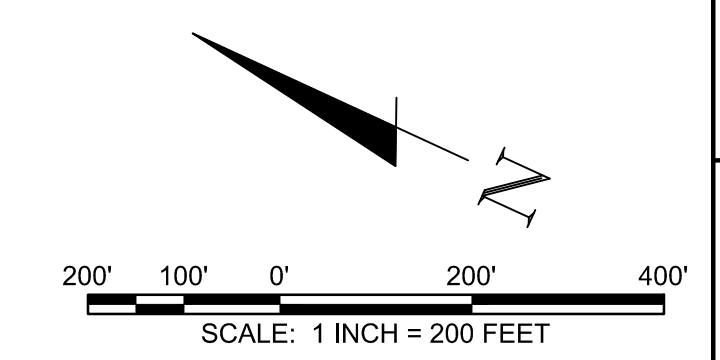

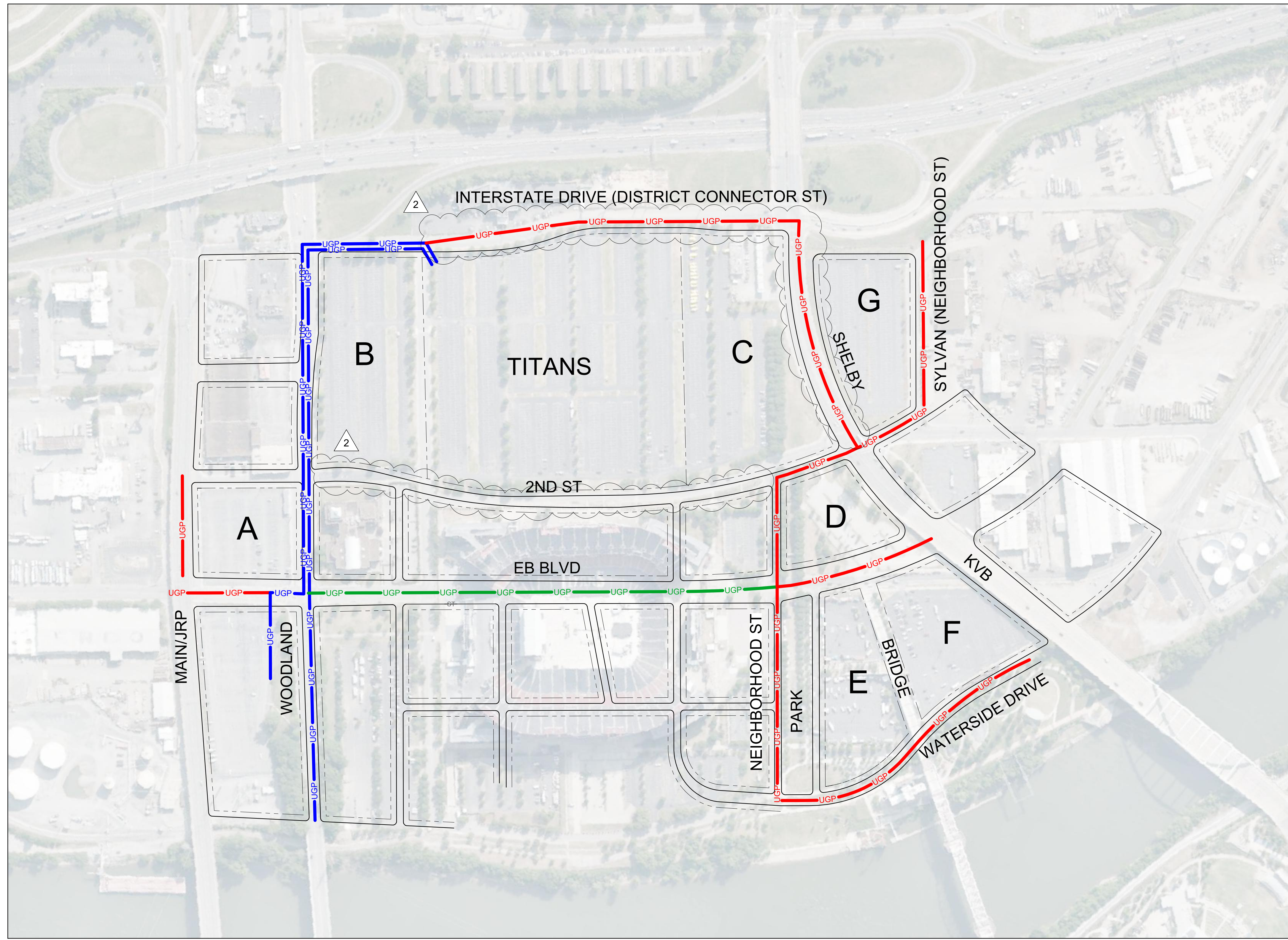

**LEGEND**

- UGP — TITANS
- UGP — PROPOSED
- UGP — FUTURE (AFTER STADIUM OPENING)

**NOTE**  
TELECOM TO FOLLOW THE SAME ROUTING AS UNDERGROUND POWER

**POWER / TELECOM**

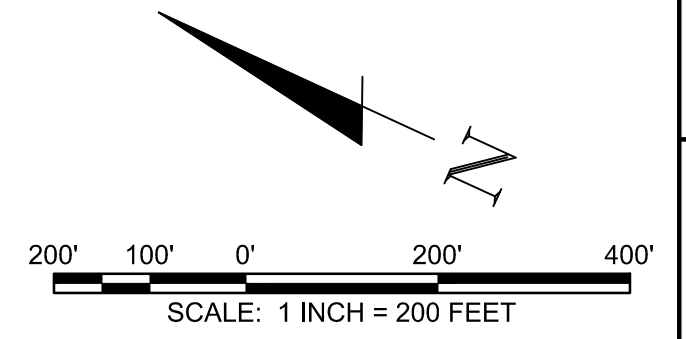

USER: JMBROYD  
FILE: F:\38\38800\388000004\_CAD\CIVIL\PLT\C3.00.dwg  
SAVED: 12/1/2023  
PLOTTED: 12/1/2023

PRELIMINARY  
NOT FOR  
CONSTRUCTION  
DATE \_\_\_\_\_

**POWER / TELECOM PLAN**  
**THE FALLON COMPANY**  
**EAST BANK IDA**  
NASHVILLE, TN

REV.	DR.	CHK.	DATE	DESCRIPTION

Exhibit 6

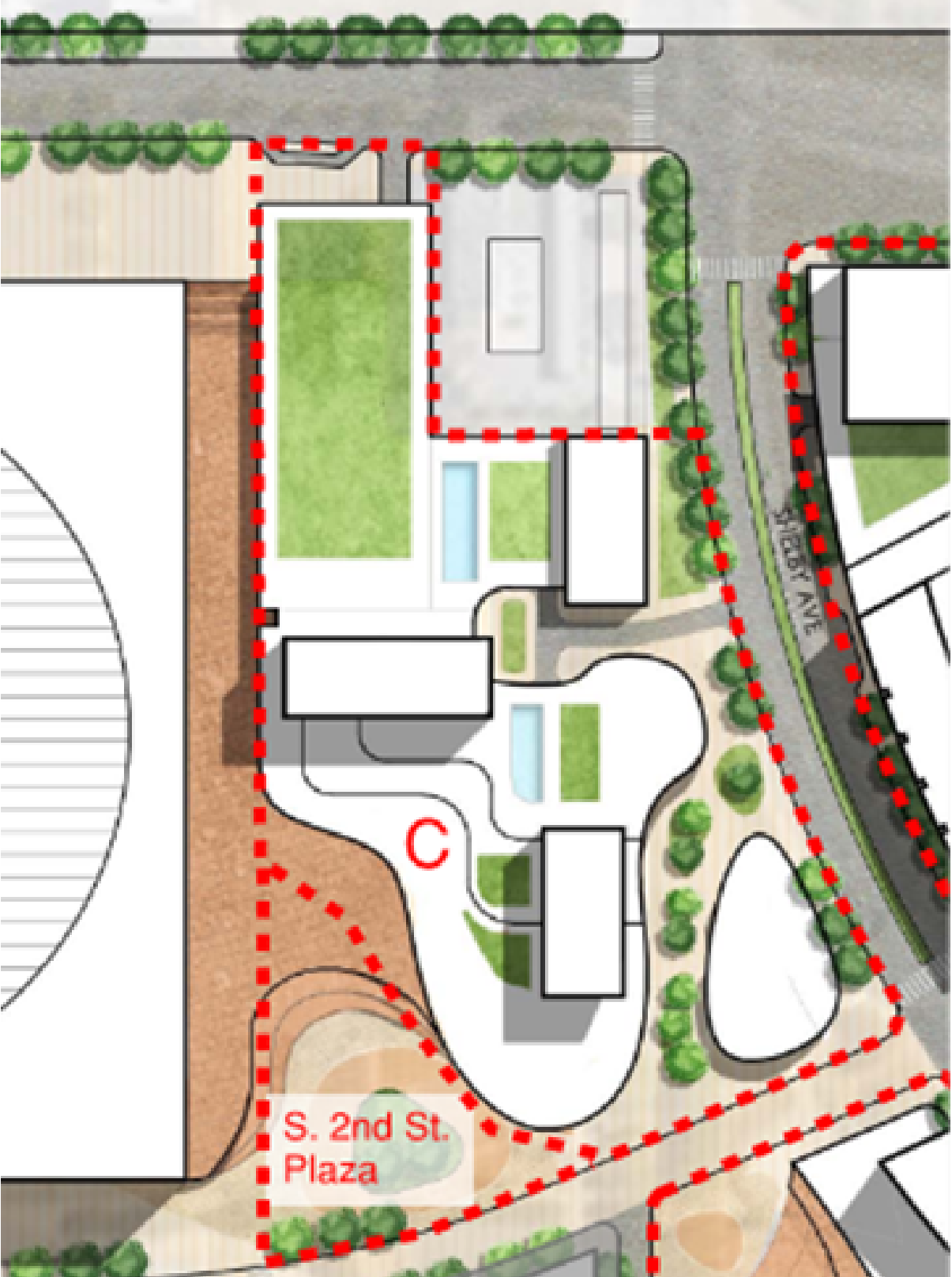

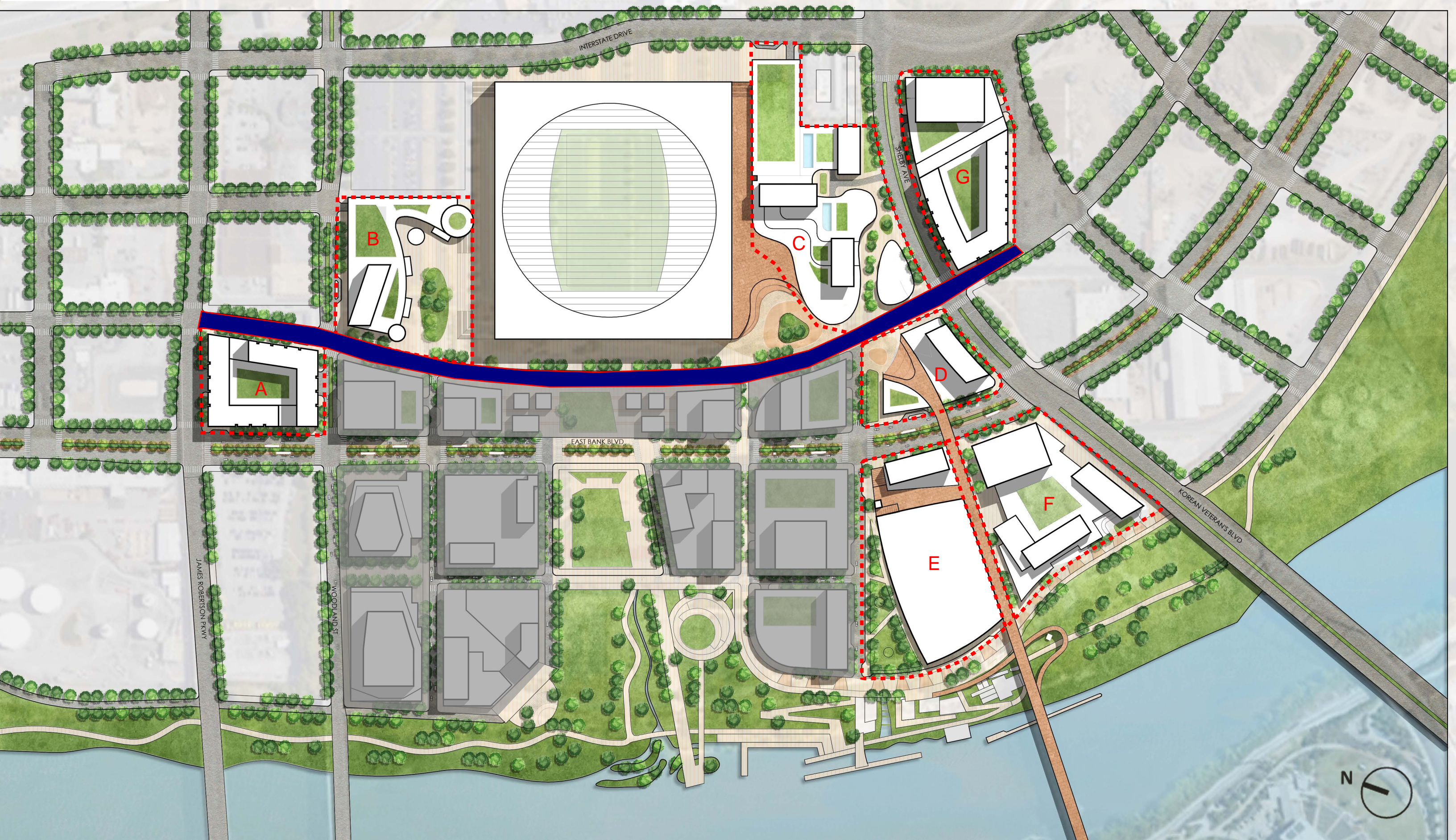

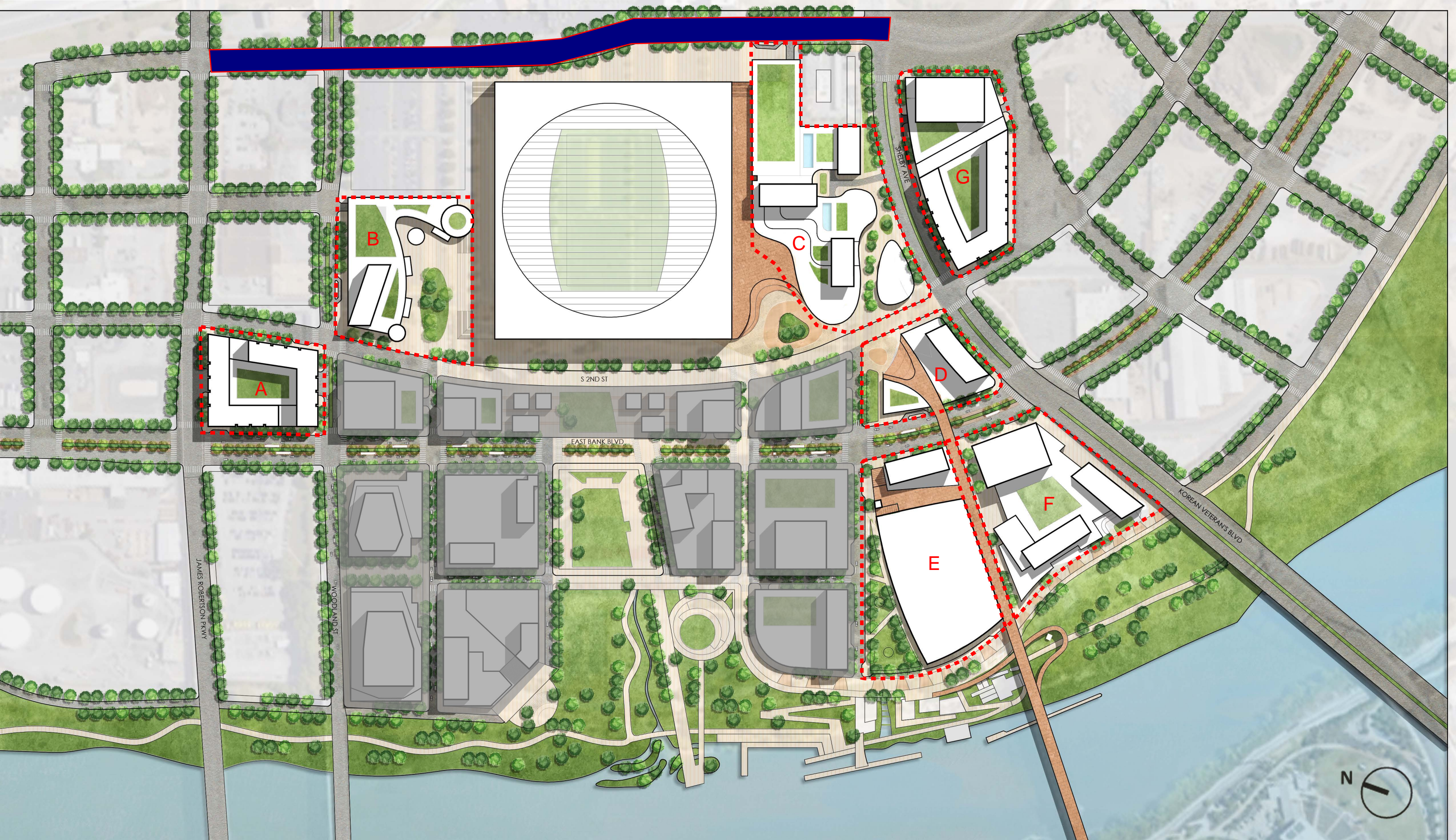



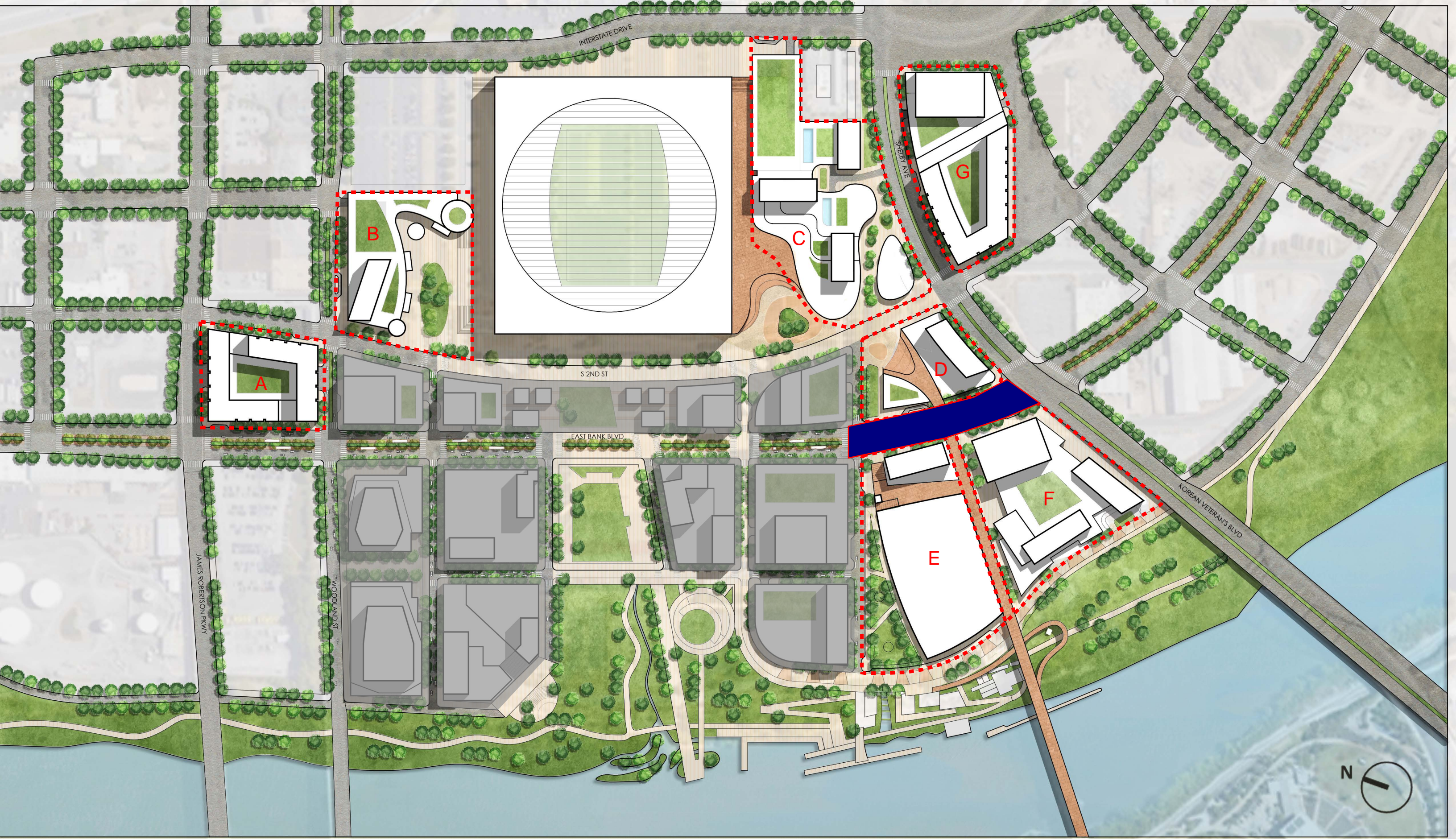

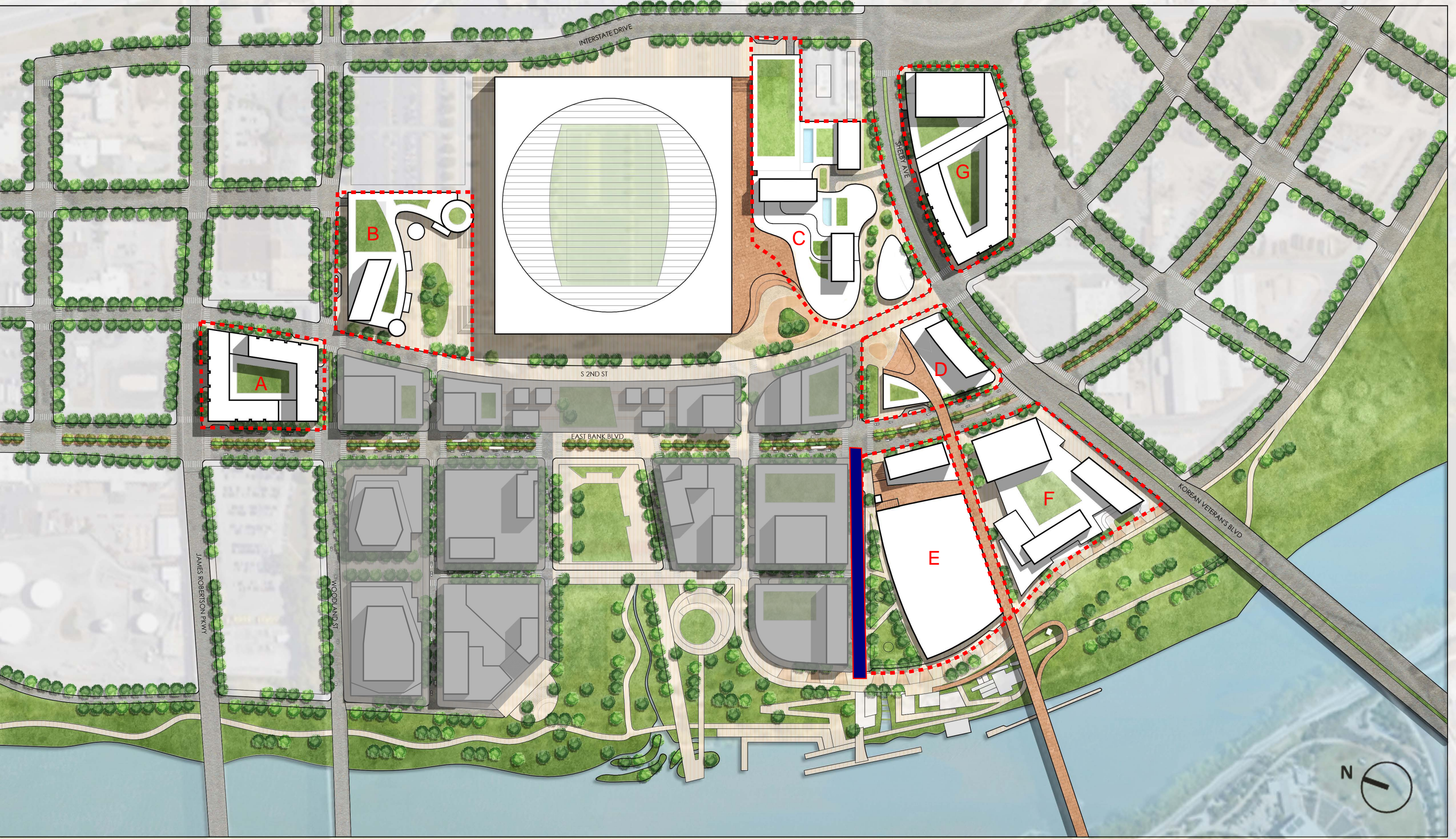

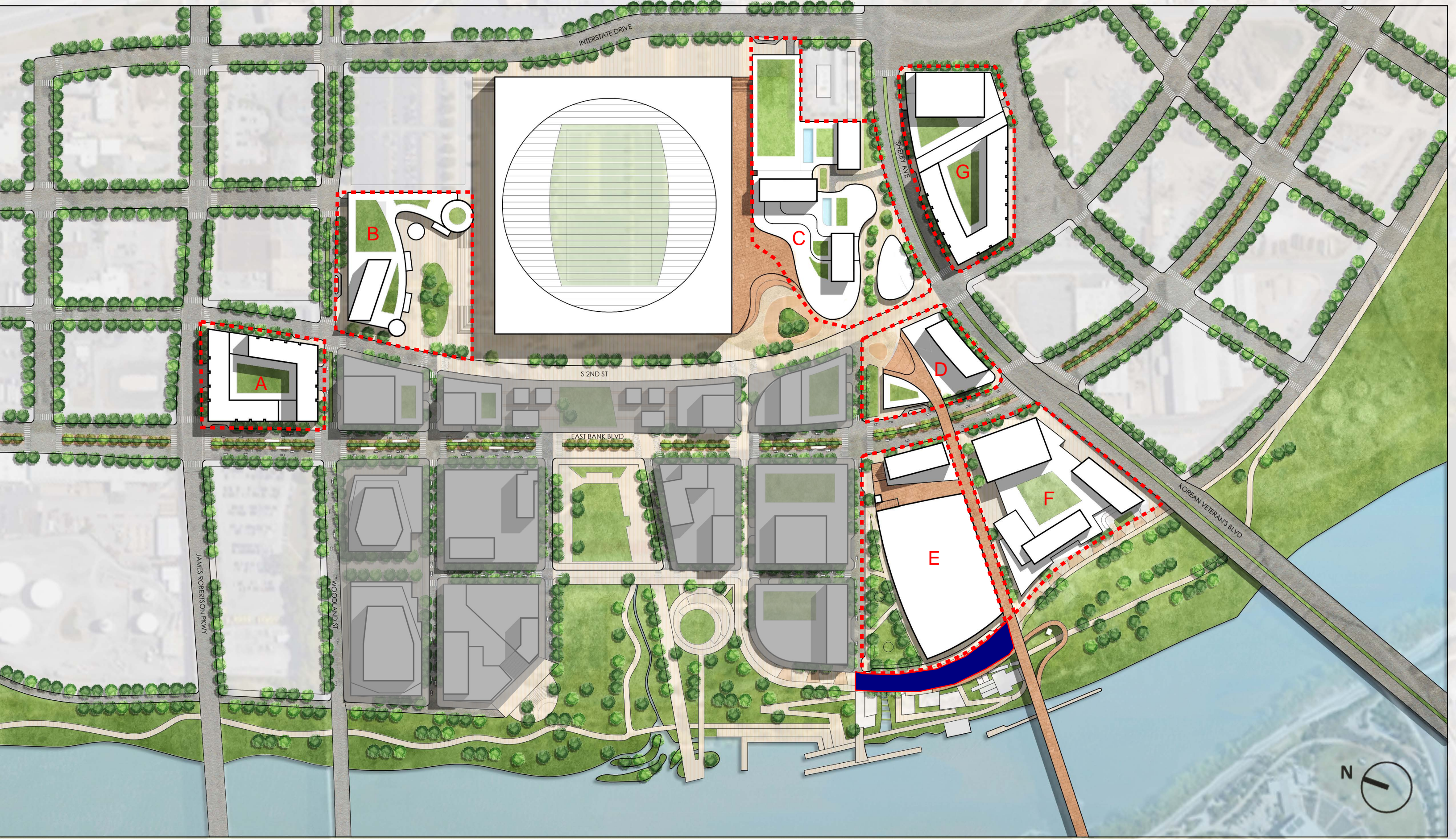

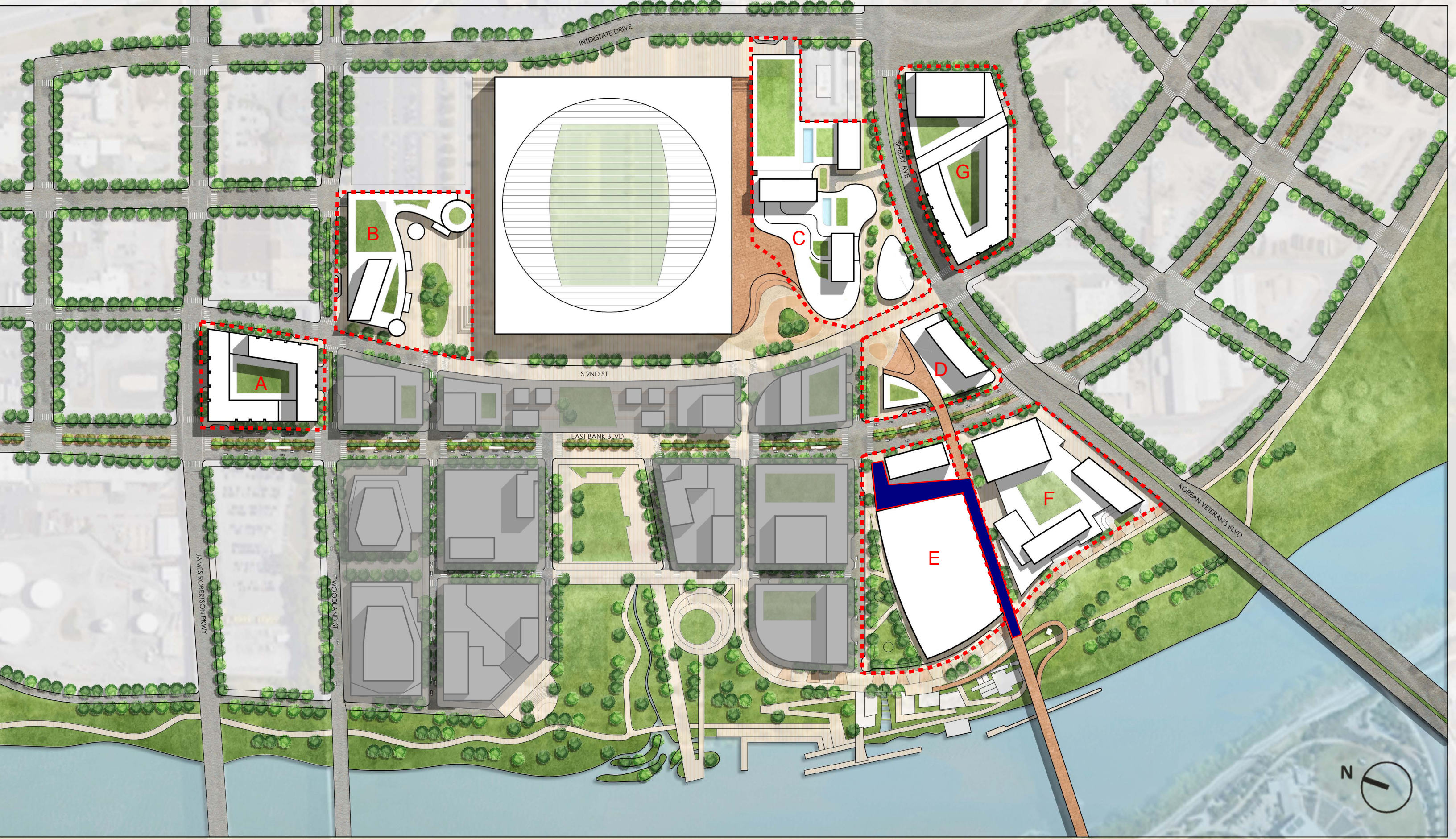

**IDA MASTER PLAN**  
January 17, 2023

DRAFT

DRAFT

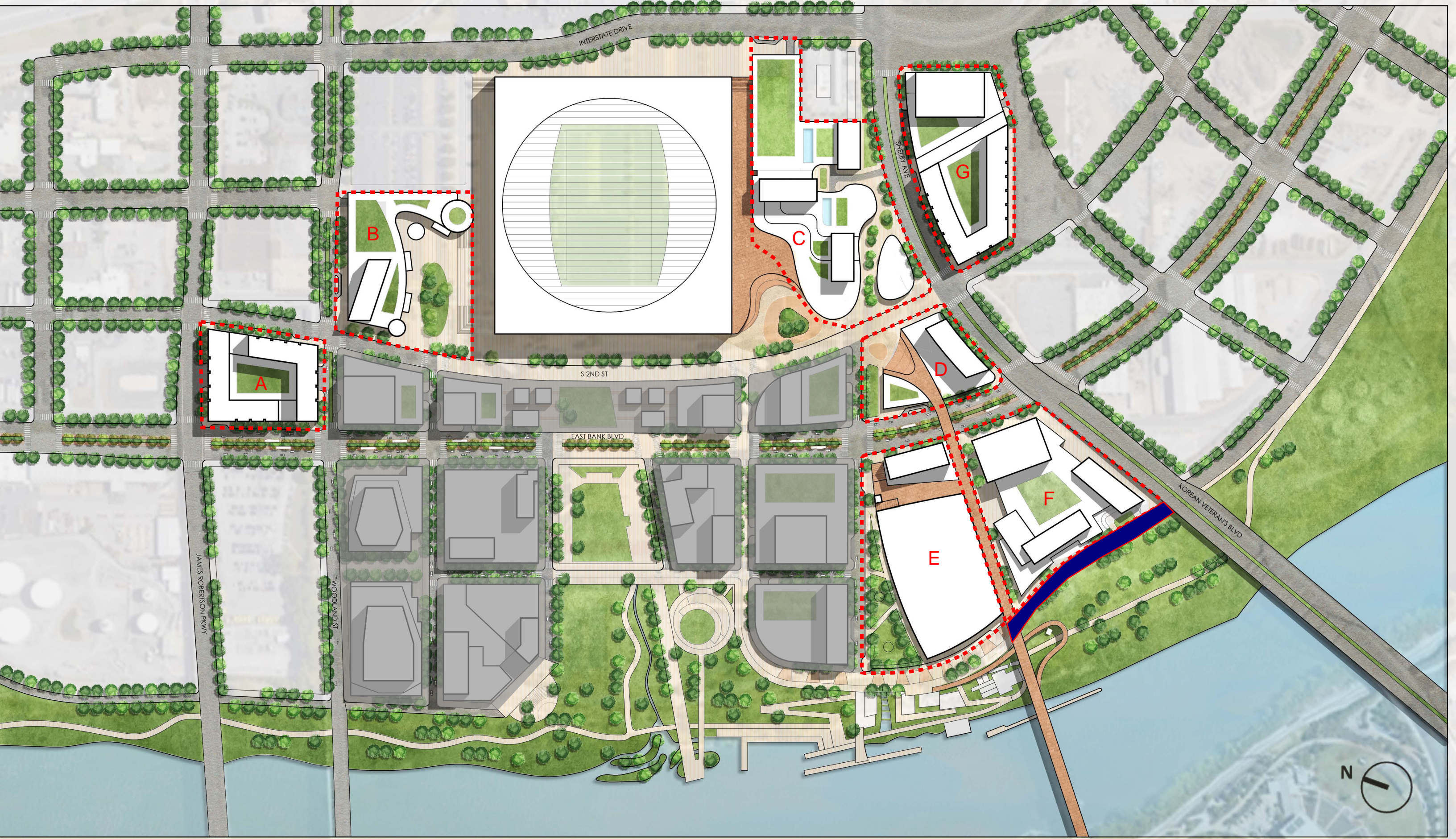

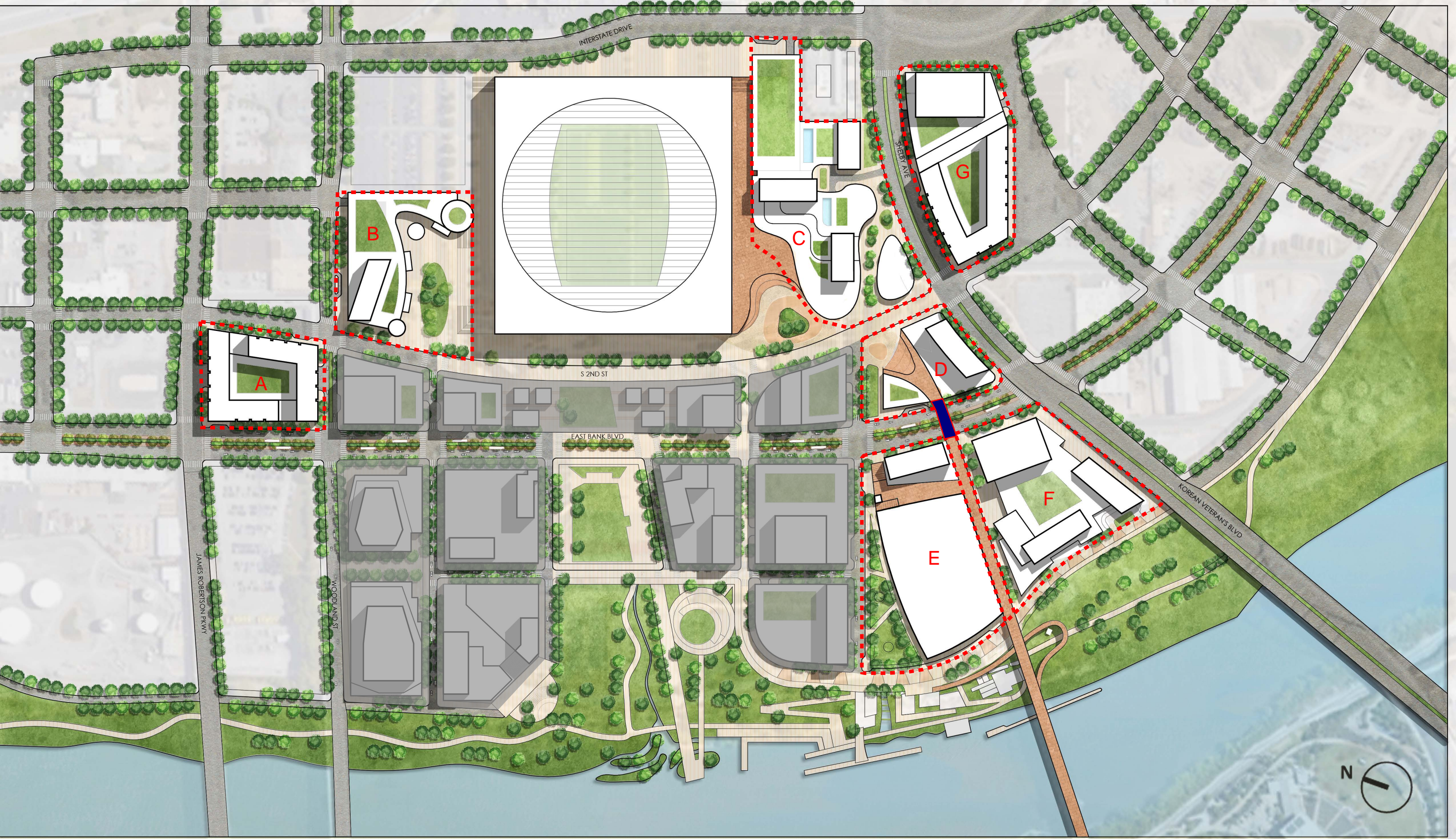

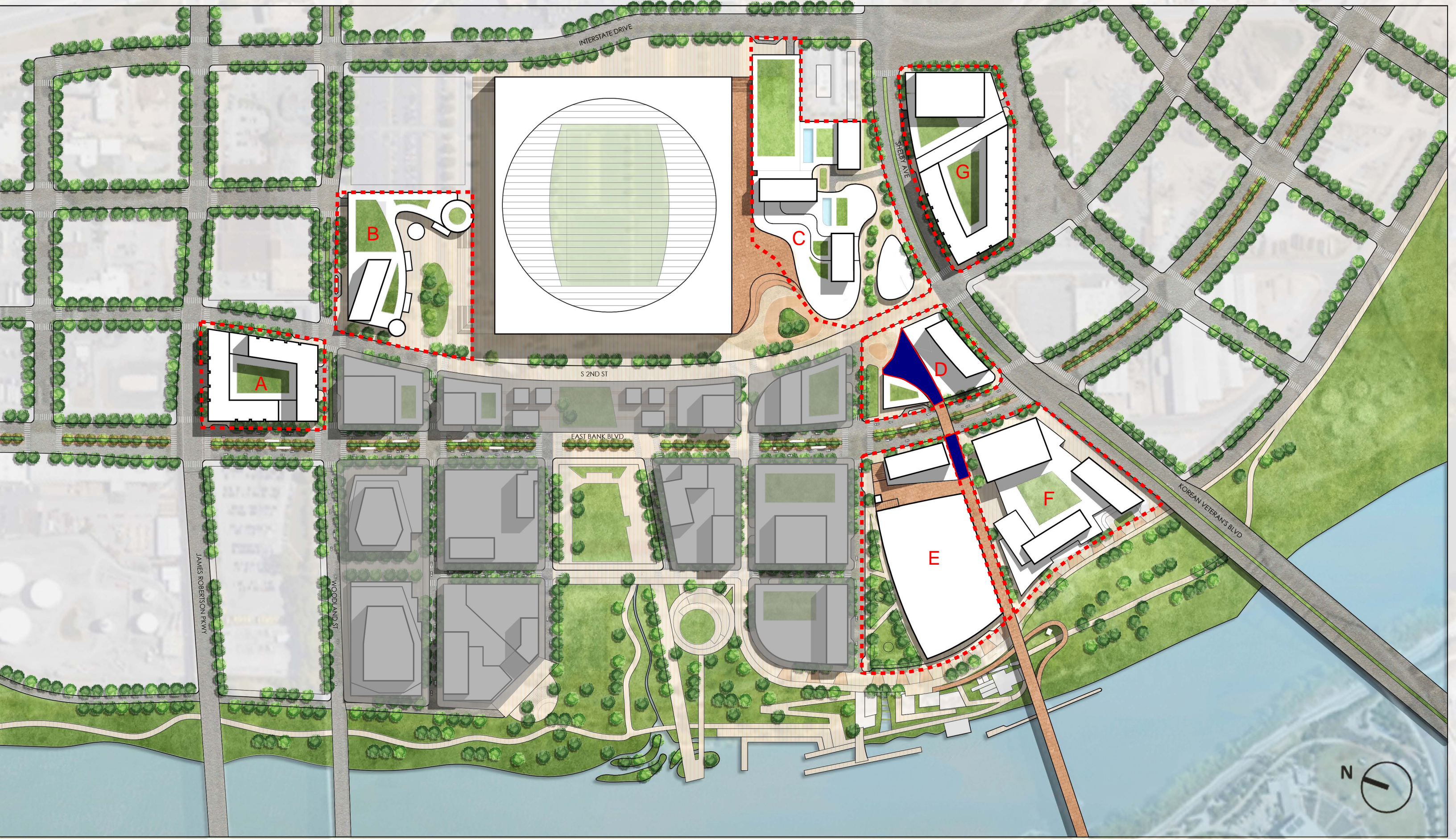

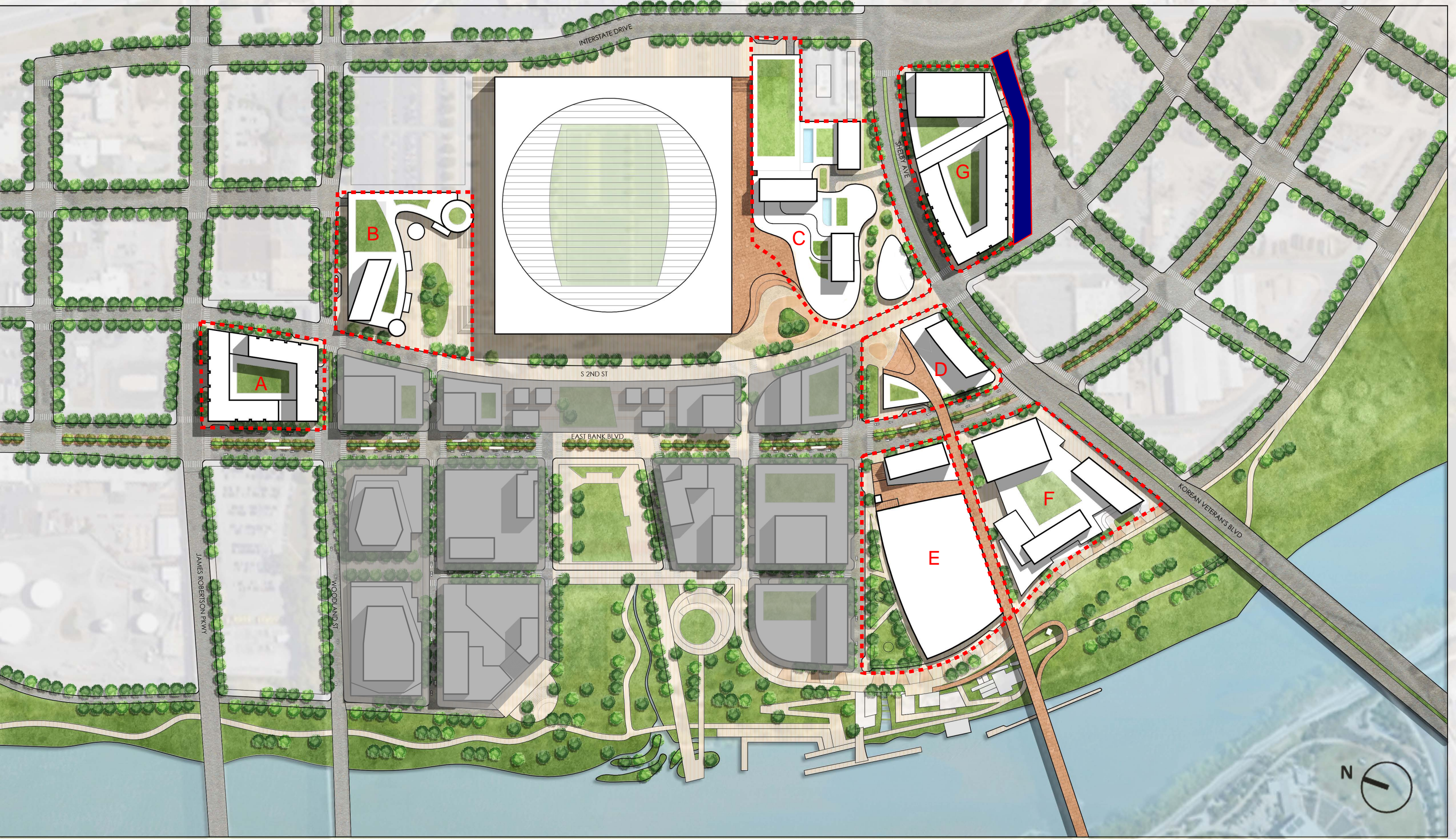



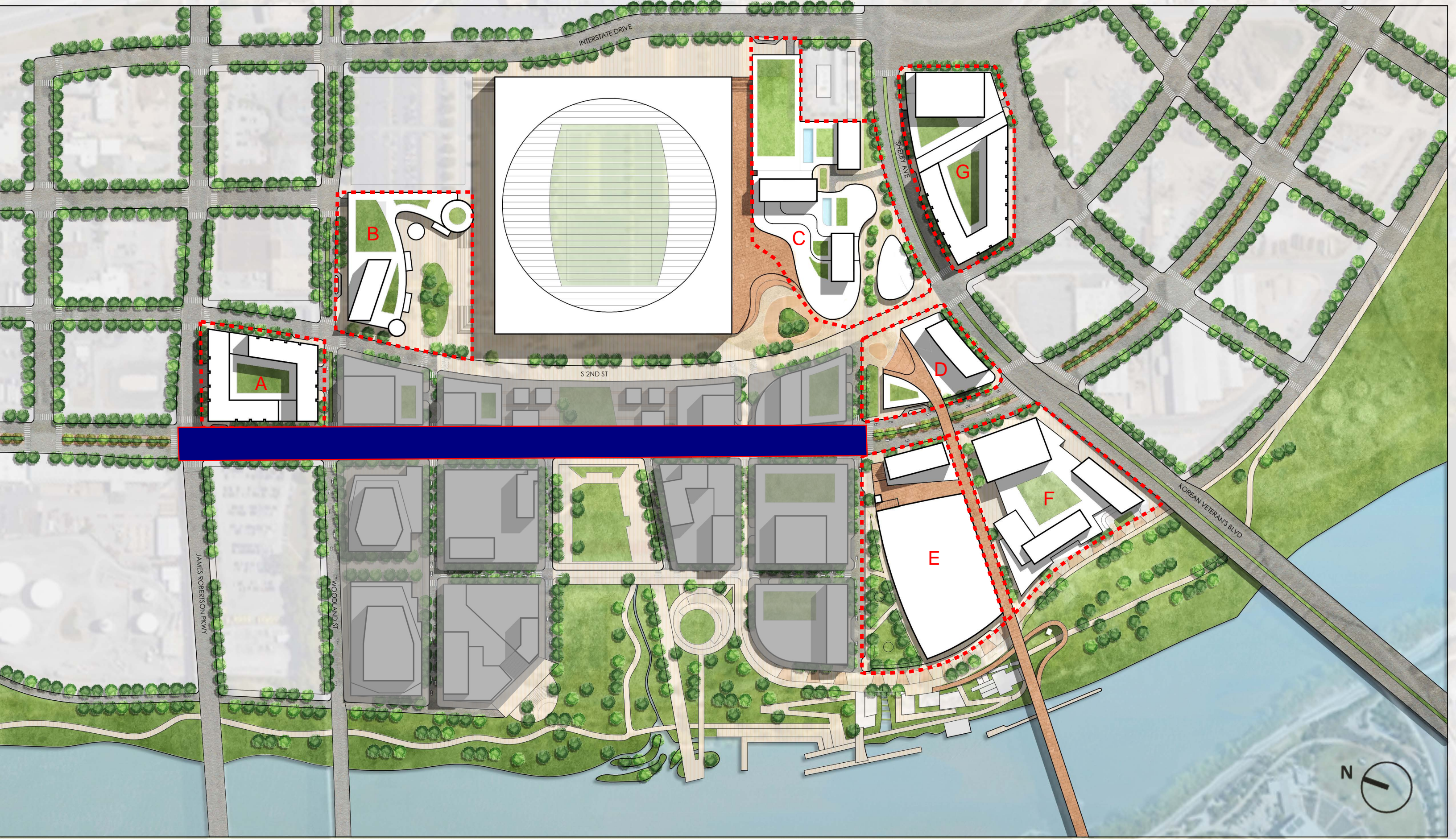

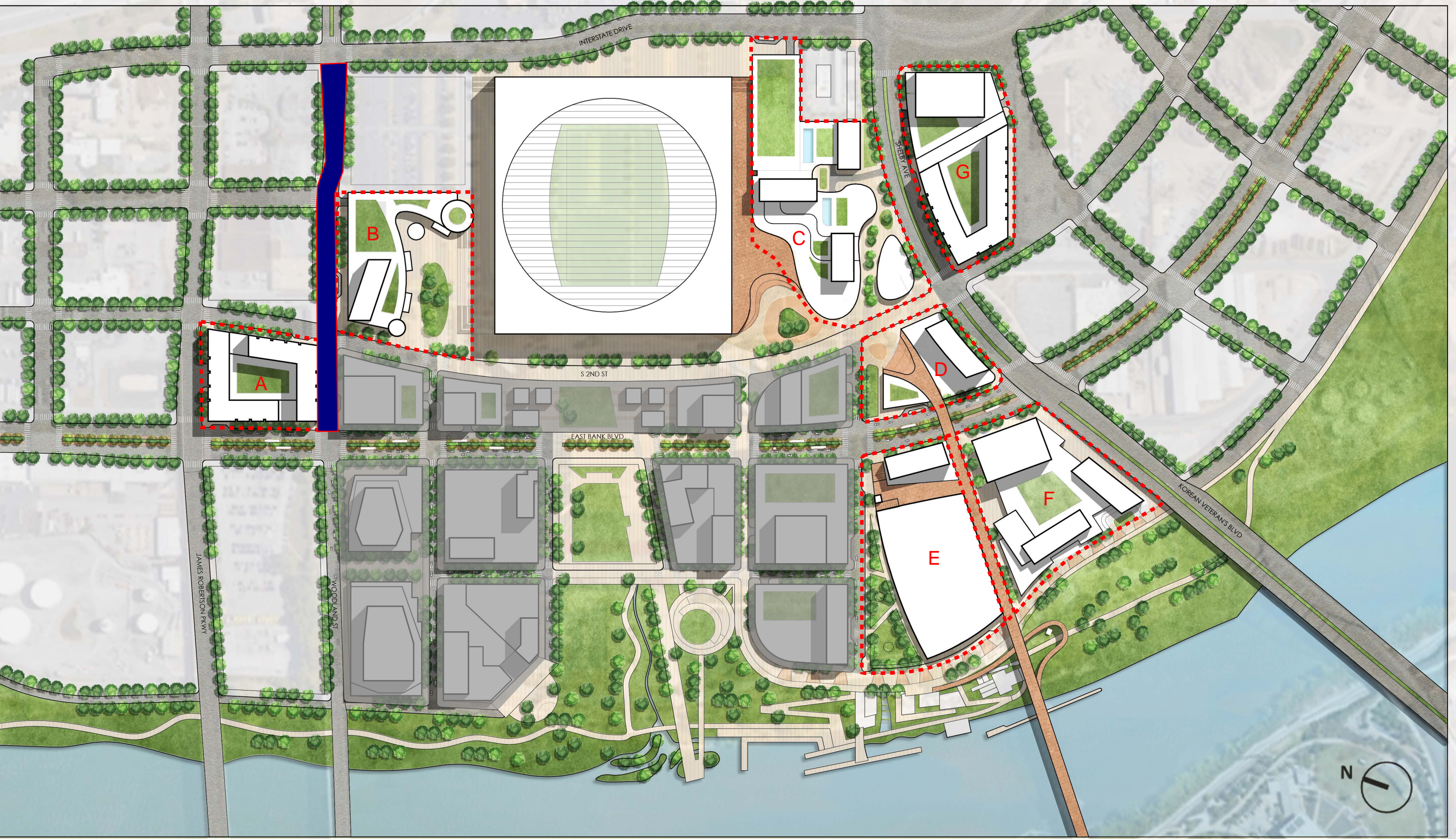

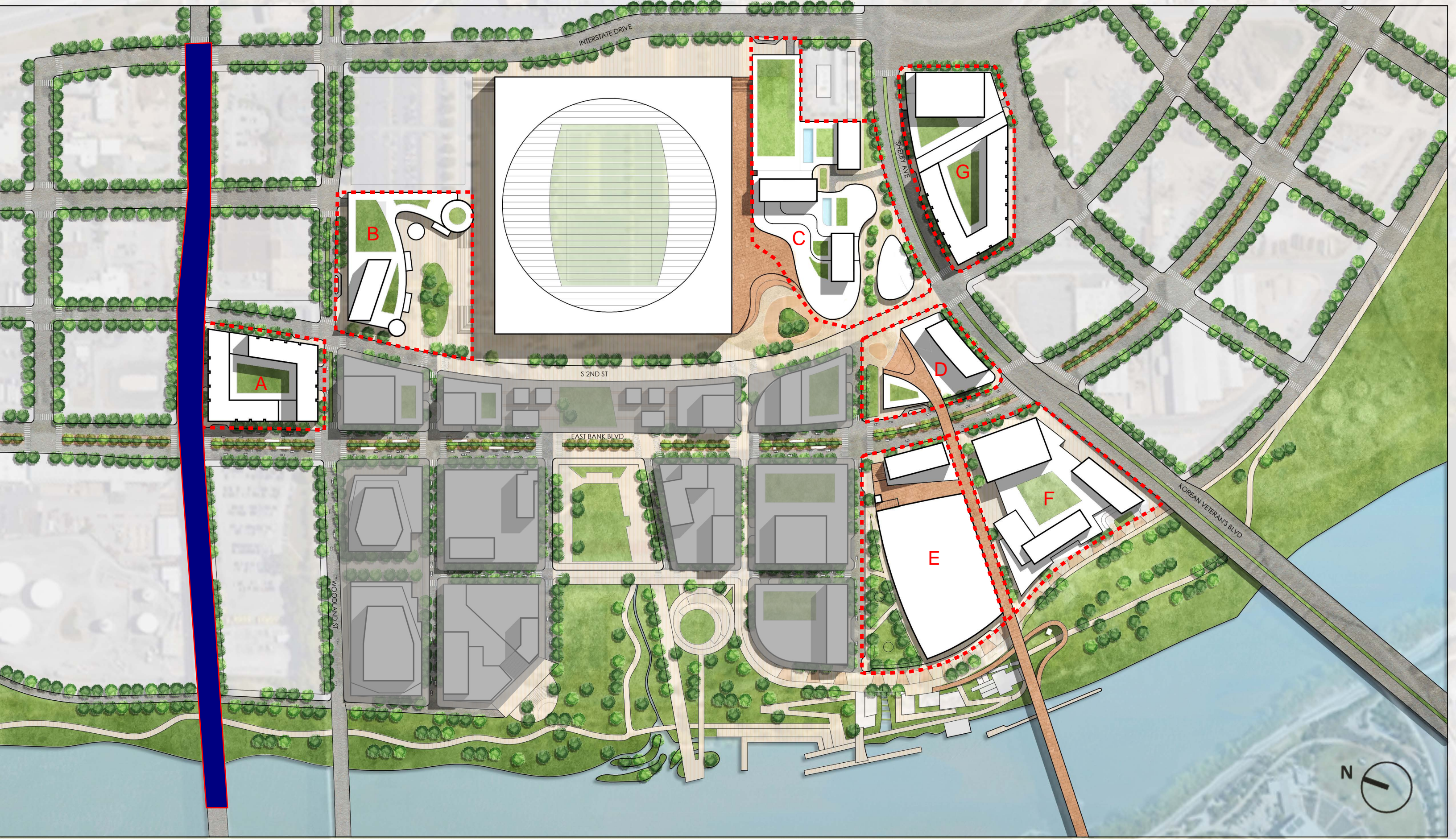

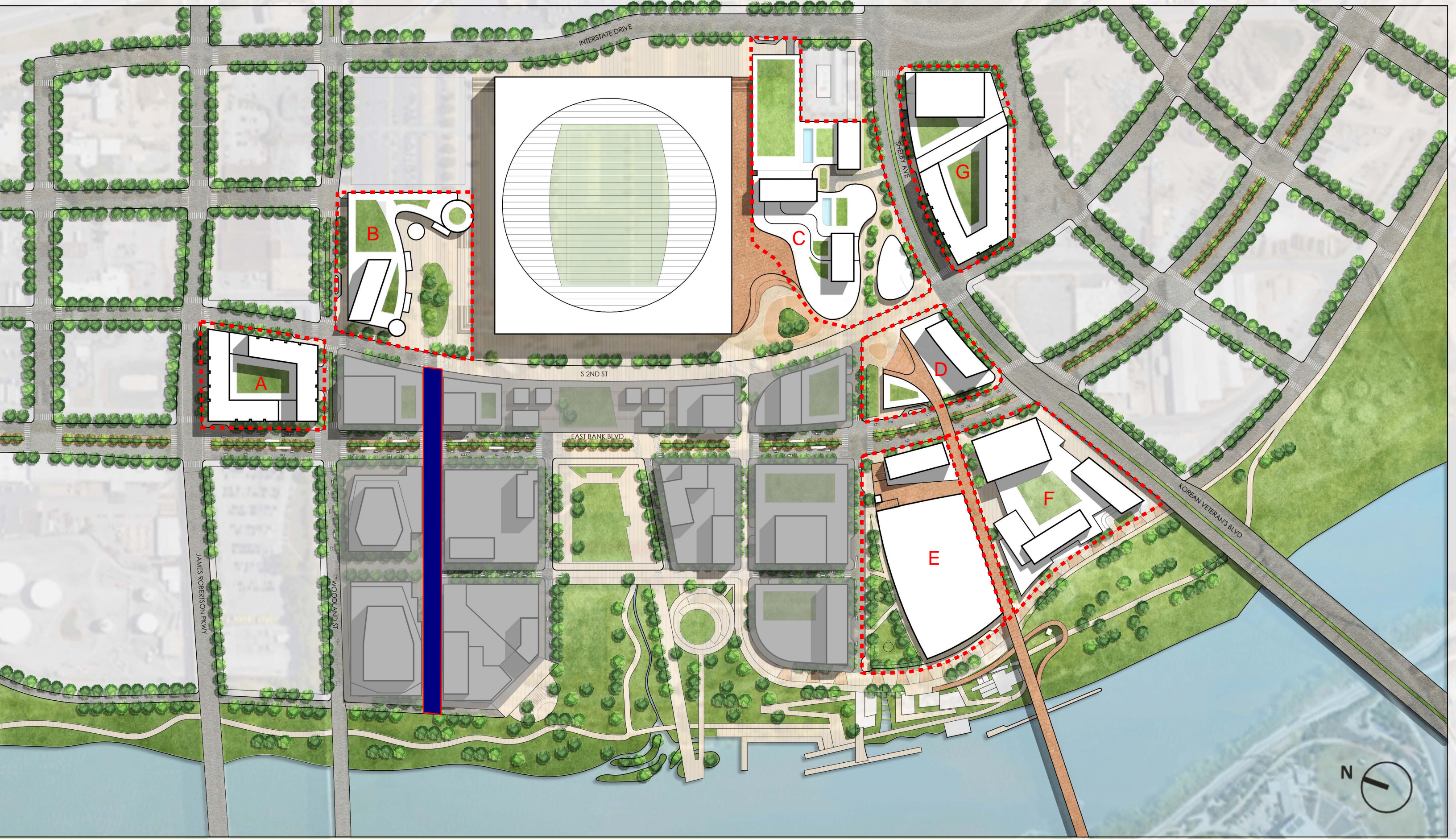

**IDA MASTER PLAN**  
January 17, 2023

DRAFT

DRAFT

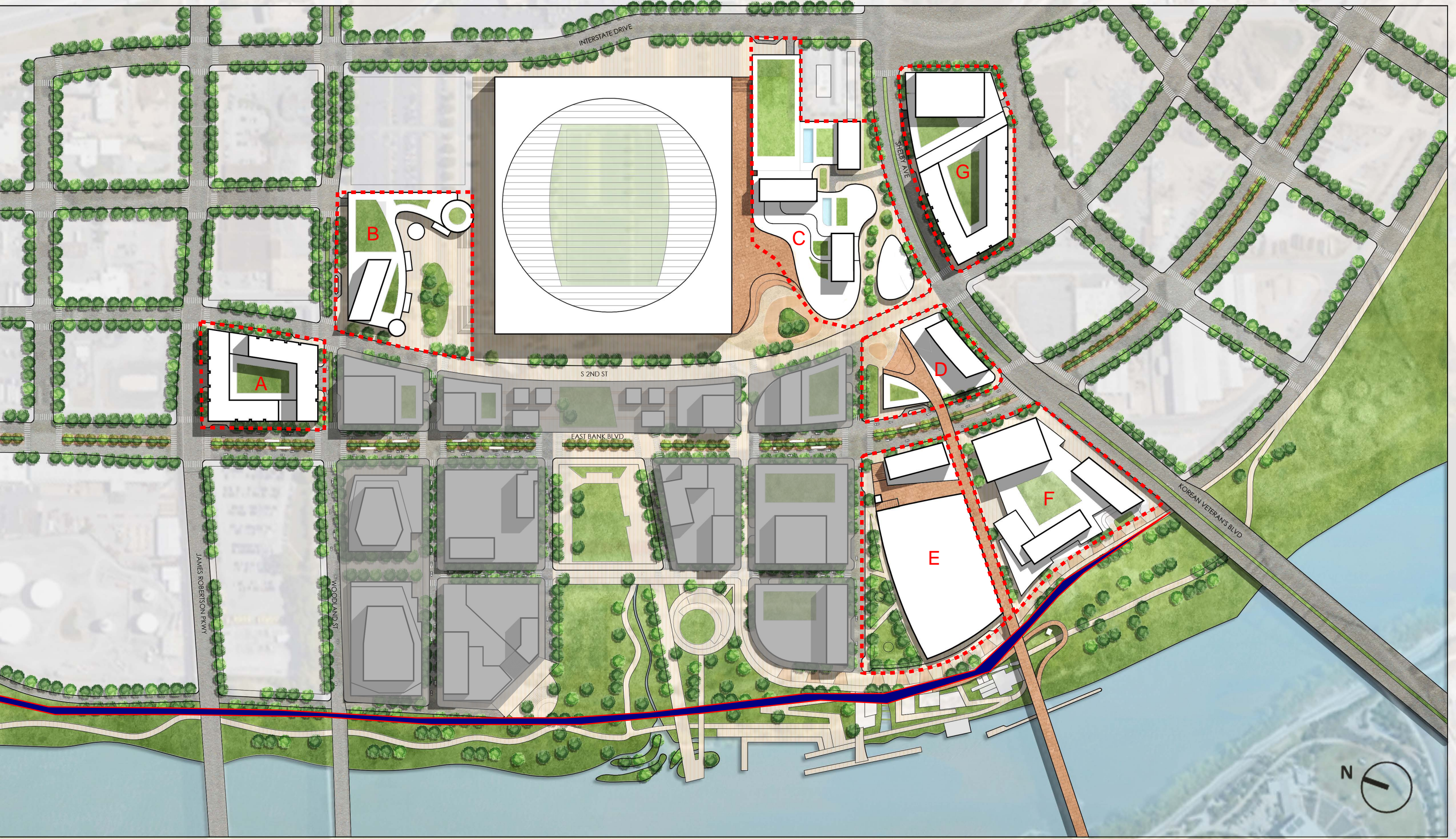

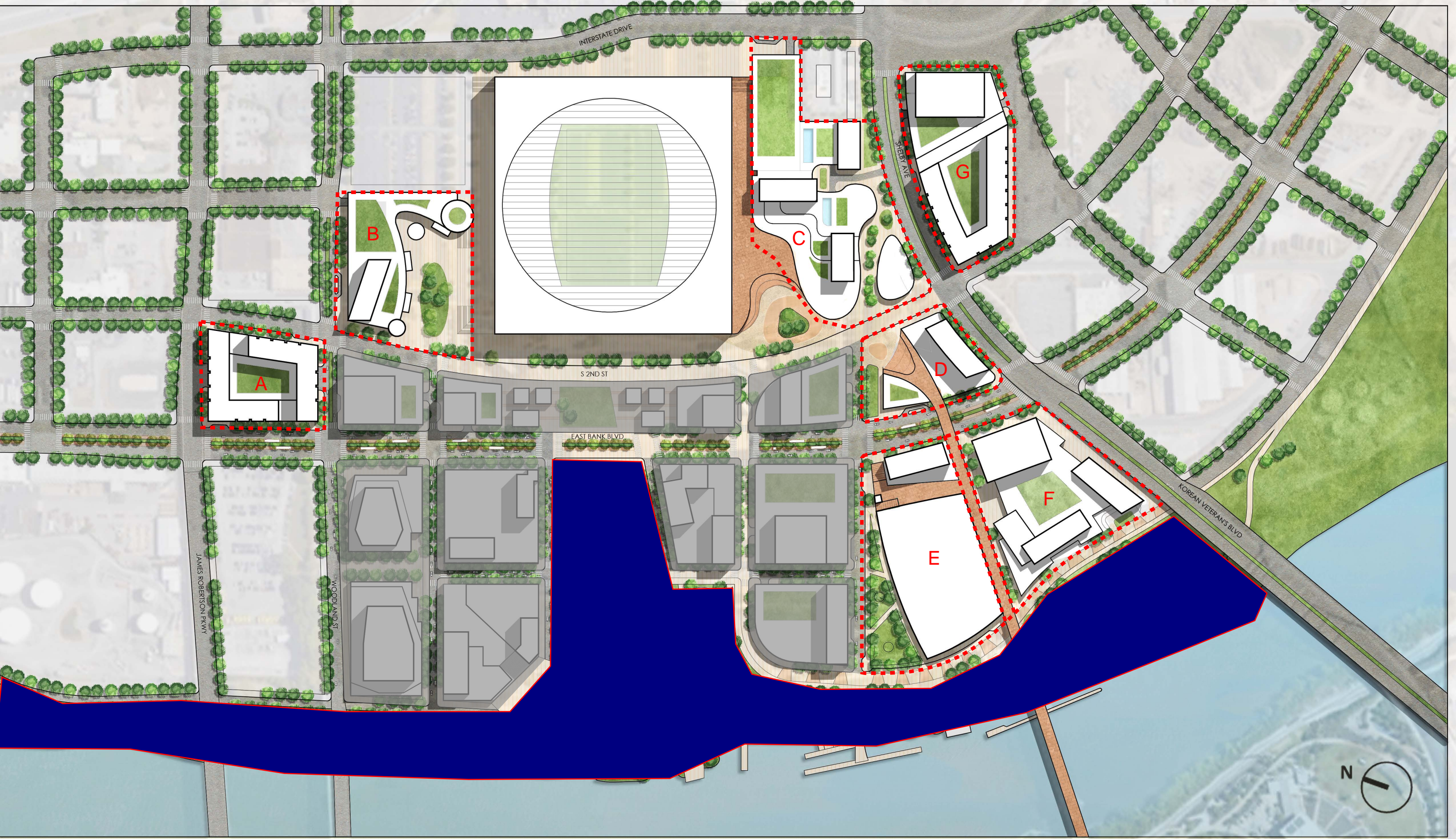

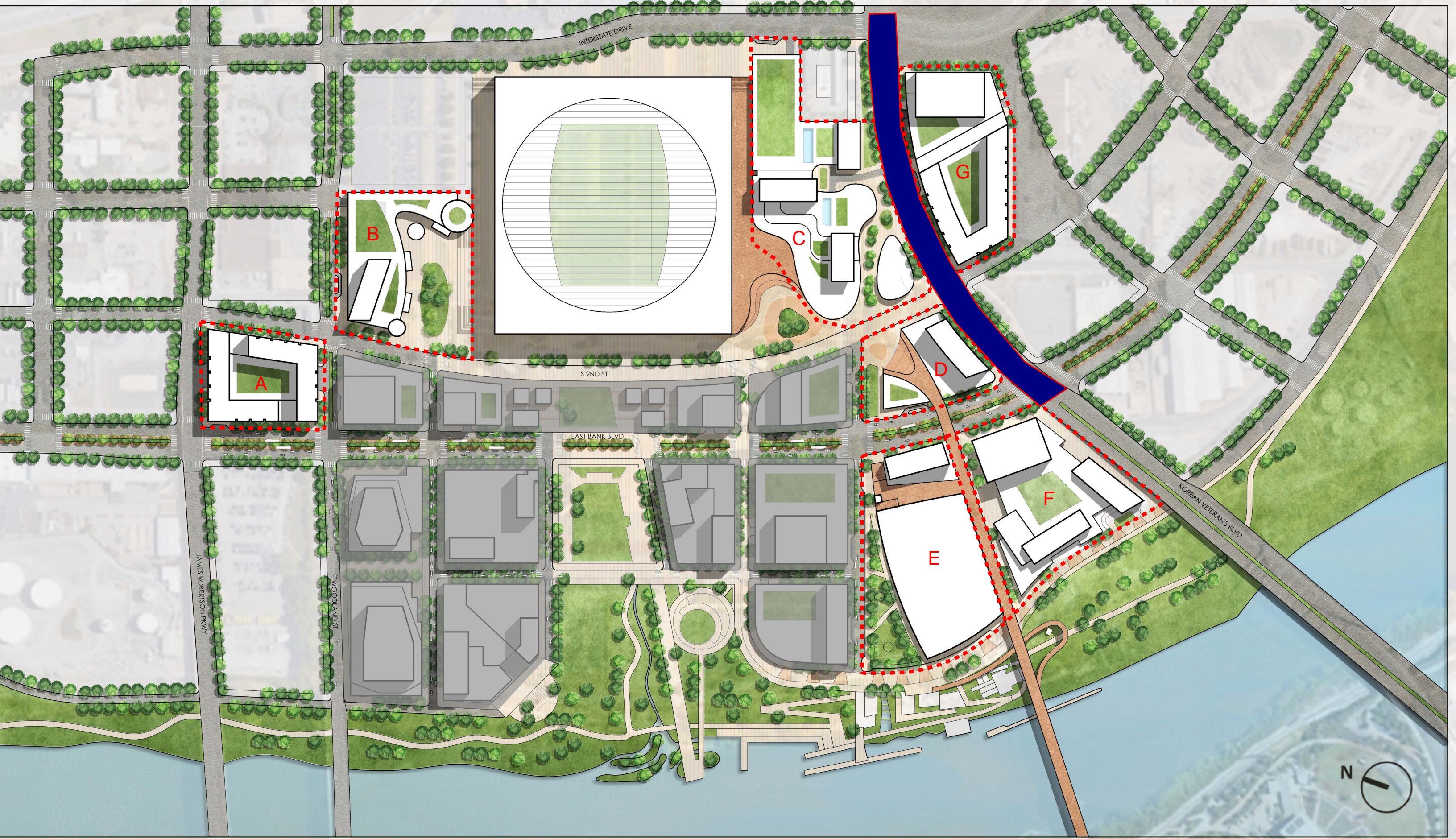

**Exhibit E**

Preliminary Development Schedule



# EAST BANK Preliminary Development Schedule

February 22, 2024

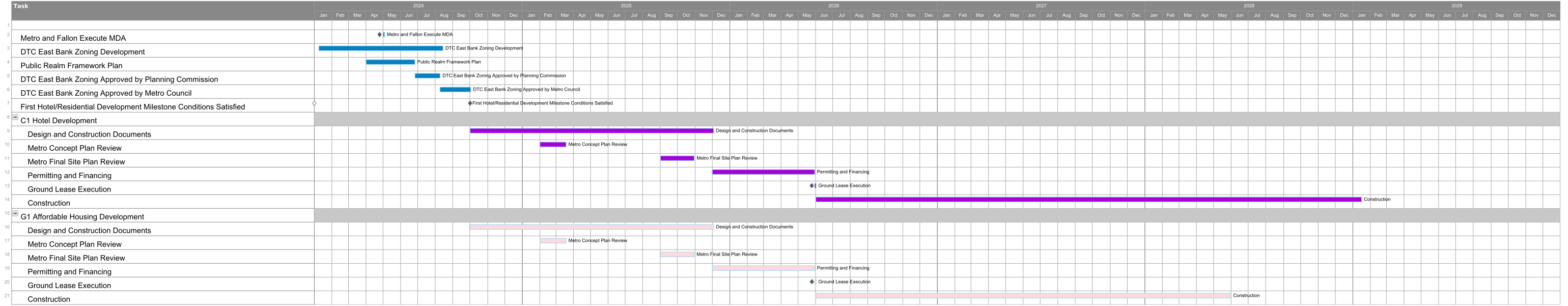

**Exhibit F**

Required Insurance

## **Insurance Requirements**

Developer shall procure and maintain, or cause to be procured and maintained, prior any entry by Developer or any of Developer's representatives at the Premises, at Developer's sole cost and expense and until the completion of all such activities and any additional time period required below, the following types of insurance and minimum coverage amounts written by insurers rated by A.M. Best & Co., with a minimum rating of (or equivalent to) A-/ VIII and qualified to do business in Tennessee:

(a) Workers' compensation insurance as required by any applicable law, and employer's liability insurance shall in amounts sufficient to satisfy local statutes (if any), but in any event not less than \$500,000 each accident for Bodily Injury by accident, \$500,000 each employee for Bodily Injury by disease, and \$500,000 policy limit for Bodily Injury by disease;

(b) Commercial general liability insurance, including blanket contractual liability, personal injury and broad form property damage, with minimum limits of not less than \$1,000,000 each occurrence, \$1,000,000 personal and advertising injury, \$2,000,000 general aggregate, and \$2,000,000 products-completed operations aggregate;

(c) Automobile liability insurance for all vehicles, including but not limited to all owned, hired (or rented) and non-owned vehicles, with minimum limits of not less than \$1,000,000 combined single limit (scheduled, hired and non-owned vehicles); and

(d) Umbrella liability insurance with minimum limits of not less than \$5,000,000 each occurrence and \$5,000,000 general aggregate, which shall be "follow form" coverage that is at least as broad as the primary commercial general liability and automobile liability insurance.

2. Each of the Indemnitees shall each be included as an additional insured under the commercial general liability and umbrella liability policies with coverage equal to the full policy limits. Coverage shall apply on a primary, non-contributory basis on all insurance policies other than workers' compensation. All of the insurance policies carried by the Developer shall be written on an "occurrence" basis and shall include a waiver of subrogation provision in favor of the Indemnitees.

3. Developer shall, prior any entry by Developer or any of Developer's representatives at the Premises, deliver to Metro certificates of insurance evidencing that such coverages are in full force and effect and the required parties are included as additional insureds thereon. Developer shall also furnish certificates of insurance evidencing renewal or replacement coverage to Metro not less than five (5) days prior to expiration of any such policies. The underlying policies and accompanying certificates of insurance shall provide for at least thirty (30) days' prior written notice to Developer of cancellation (unless cancellation is for nonpayment of premium, in which case ten (10) days' notice will suffice).

4. To the greatest extent permitted by law, Developer waives any and all rights of recovery, claim, action, or cause of action against each of the Indemnitees arising from any personal injury or loss or damage to any property arising out of the Developer's activities under this Agreement, regardless of cause or origin, to the extent covered by the insurance policies required hereunder.

5. Developer shall cause each contractor, consultant or vendor engaged by Developer to enter upon or perform activities at the Premises to procure and maintain insurance meeting the requirement of, and to otherwise comply with, the requirements of this **Exhibit F**.

**Exhibit G**

Form of Completion Guaranty

## COMPLETION GUARANTY

**THIS COMPLETION GUARANTY** (this “**Guaranty**”) is made as of the \_\_\_ day of \_\_\_\_\_, 202\_\_, (the “**Effective Date**”) by [\_\_\_\_\_] (“**Guarantor**”), in favor of **THE METROPOLITAN GOVERNMENT OF NASHVILLE AND DAVIDSON COUNTY** (“**Owner**”).

### RECITALS

- A. Pursuant to the Ground Lease between Owner and [\_\_\_\_\_] a Delaware limited liability company (together with its successors and assigns, “**Tenant**”), dated as of \_\_\_\_\_, 202\_\_ (as the same may be amended from time to time, the “**Ground Lease**”), Owner has leased to Tenant a parcel of land containing approximately [\_\_\_] acres and located at [\_\_\_\_\_] in Nashville, Tennessee, as more particularly described in the Ground Lease (the “**Premises**”).
- B. Tenant desires to develop the Premises as more particularly set forth in, and subject to the terms and conditions of, the Ground Lease.
- C. Pursuant to the Ground Lease, this Guaranty is required to be delivered to guaranty Tenant’s obligations under the Ground Lease with respect to the construction of [PROJECT] by Tenant (the “**Project**”).
- D. Guarantor is an Affiliate of Tenant and has a financial interest in the Premises.
- E. All capitalized terms used but not otherwise defined herein shall have the meanings ascribed to such terms in the Ground Lease.

NOW, THEREFORE, as an inducement to Owner to enter into the Ground Lease, and for other good and valuable consideration, the receipt and legal sufficiency of which are hereby acknowledged, Guarantor hereby agrees as follows:

1. **GUARANTY**. Guarantor absolutely, unconditionally, and irrevocably guarantees to Owner (and Owner’s permitted successors and assigns as landlord under the Ground Lease) the full, complete and punctual payment and performance of the following obligations, duties, covenants and agreements of Tenant under the Ground Lease: (a) the obligation to achieve Substantial Completion of the Project, free and clear of all liens, as and when required pursuant to the terms of the Ground Lease; (b) to pay all hard and soft costs required for the lien-free Substantial Completion of the Project as and when required in accordance with the terms of the Ground Lease; and (c) to promptly cause the removal of any lien(s) arising from the Project by payment, bonding or other security as and when required in accordance with the terms of the Ground Lease. Guarantor acknowledges having received, reviewed and approved a true and complete copy of the Ground Lease.

2. **REMEDIES**. The obligations guaranteed by Guarantor in Section 1 are referred to herein as the “**Obligations**”. In the event of any default by Tenant in the timely performance of

the Obligations and the expiration of any applicable cure or grace period under the Ground Lease, Guarantor agrees, promptly following written demand by Owner, to perform (or cause to be performed) all the Obligations subject in all cases to the right to assert and benefit from (i) any defenses available to Tenant under the Ground Lease (except for the defenses expressly waived in this Guaranty) and (ii) claims expressly available to Tenant under the Ground Lease for extensions to the time for performance of Tenant's obligations such as Force Majeure (collectively, "**Retained Rights**"). Subject to the terms of Section 3, if Guarantor fails to timely perform the Obligations subject to the foregoing provisions of this Section 2, then if Guarantor has not performed following 30 days' prior written notice to Guarantor, Owner shall have the right, at its option, to perform any and all of the Obligations by or through any agent, contractor or subcontractor of its selection, all as Owner in its sole discretion deems proper, and, subject to the second paragraph of this Section 2, in accordance with the Final Plans and Specifications and the Ground Lease. Notwithstanding anything contained in this Guaranty or in the Ground Lease to the contrary, if (i) a court makes or enters any decree or order adjudging Tenant to be bankrupt or insolvent; (ii) a petition in bankruptcy or other insolvency proceedings seeking either liquidation or reorganization of Tenant or an arrangement under the bankruptcy laws or any other applicable debtor's relief law or statute of the United States or any state thereof is filed against Tenant and not dismissed within ninety (90) days thereafter; (iii) a receiver, trustee or assignee of Tenant in bankruptcy or any insolvency proceeding or for its property is appointed and not discharged within ninety (90) days thereafter; (iv) a court made or entered any decree directing the winding up or liquidation of Tenant and such decree or order shall continue without being vacated or dismissed for a period of ninety (90) days; or (v) Tenant voluntarily submitted to or filed a petition seeking any such decree or order or relief under any federal or state bankruptcy or insolvency laws, then, in each case Owner may, at its option, accelerate the Obligations and require to Guarantor to perform under this Guaranty.

During the course of or following any performance of Obligations undertaken by Owner or any other party on behalf of Owner in accordance with the terms of this Guaranty, Guarantor shall (i) pay within ten (10) days following written demand any out-of-pocket reasonable costs or expenses that Owner incurs arising out of its performance of the Obligations and (ii) cause any lien, claim, or demand made (except arising out of Owner's failure to pay to any third party any amounts paid by Guarantor hereunder) in connection with the Obligations to be released, paid, or bonded over. Neither the completion of construction nor the failure of said party to complete the construction shall relieve Guarantor of any liabilities hereunder; rather, such liability shall be continuing and may be enforced by Owner until the Obligations shall be performed in full. Nothing in this Guaranty shall permit Owner to modify the Project, and the Project shall be constructed by Owner or any other party on behalf of Owner in accordance with the Final Plans and Specifications, as they may have been modified in accordance with the Ground Lease, provided that the forgoing prohibition shall not apply to modifications made in the ordinary course, which are necessary to complete the Project in a manner consistent with comparable projects, such as minor field work changes.

The parties agree that, in the event of any breach by a party of any covenant or obligation contained in this Guaranty, the other party shall be entitled, to seek and, if granted, to obtain (a) a decree or order of specific performance to enforce the observance and performance of any covenant or obligation set forth in this Guaranty, and (b) an injunction restraining any breach or threatened breach.

3. **FORBEARANCE.** Notwithstanding anything to the contrary contained herein, and subject to the terms of this Section 3, Owner's rights under this Guaranty are subject and subordinate to the rights of any and all Permitted Leasehold Mortgagee(s) and Permitted Mezzanine Lender(s) for which Owner has been provided written notice of their Leasehold Mortgage or Mezzanine Financing Security (as applicable) in accordance with the terms of the Ground Lease; provided, however, that if at any time (a) a Permitted Leasehold Mortgagee or Permitted Mezzanine Lender for which Owner has been provided written notice of a Leasehold Mortgage or Mezzanine Financing Security (as applicable) in accordance with the terms of the Ground Lease, and in each case, that is not an Affiliate of Tenant, is holding a completion guaranty made by Guarantor and/or any other Affiliate of Tenant with respect to the Project (a "**Loan Completion Guaranty**"), (b) a default by Tenant in the performance of the Obligations has occurred and is continuing beyond applicable notice and cure periods, and (c) a Permitted Leasehold Mortgagee or Permitted Mezzanine Lender, as applicable, shall fail to use commercially reasonable efforts to commence enforcement of its rights under any such Loan Completion Guaranty for a period of nine (9) months with respect to all Obligations (the "**Trigger Period**"), then Owner shall, upon notice to such Permitted Leasehold Mortgagee or Permitted Mezzanine Lender, as applicable, Tenant, and Guarantor, have the right to enforce Guarantor's performance of the Obligations hereunder after forbearing from exercising such right for a period of not less than ninety (90) days from the expiration of the Trigger Period (the "**Forbearance Period**") to allow such Permitted Leasehold Mortgagee or Permitted Mezzanine Lender, as applicable, an opportunity to commence enforcement of its remedies under its Loan Completion Guaranty. Notwithstanding the foregoing, Owner shall have no obligation to forbear from exercising its rights hereunder if such Permitted Leasehold Mortgagee or Permitted Mezzanine Lender, as applicable, consents, in its sole discretion, in writing to Owner exercising its rights hereunder with respect to the Obligations prior to the expiration of the Forbearance Period.

Notwithstanding any performance or undertaking by a Permitted Leasehold Mortgagee, Permitted Mezzanine Lender, or any other party with respect to all or any portion of the Obligations, Guarantor shall continue to be obligated under this Guaranty for the performance of the Obligations subject to the provisions of this Section 3. Owner shall not be obligated to pursue any remedy against any such Permitted Leasehold Mortgagee, Permitted Mezzanine Lender, or other party succeeding to the interest of Tenant under the Ground Lease and any failure by such Permitted Leasehold Mortgagee, Permitted Mezzanine Lender(s), or other party to perform all or any portion of the Obligations shall not excuse Guarantor from any Obligations hereunder and shall not be a defense to Owner's rights hereunder. Nothing in this Section 3 shall be deemed to create any right of Owner against any Permitted Leasehold Mortgagee or Permitted Mezzanine Lender(s) or their respective successors and assigns.

4. **INDEMNIFICATION; ENFORCEMENT COSTS.** Guarantor hereby agrees indemnify, defend and hold harmless Owner and the other Landlord Parties from and against any and all Liabilities that Owner suffers or incurs, or that otherwise arises out of Owner's performance of the Obligations in accordance with this Guaranty; provided, however, that the foregoing indemnification shall not extend to indirect, consequential, special, punitive or speculative damages (including, but not limited to, loss of profit or business loss or interruption) and shall exclude all Liability to the extent (i) caused by the act, omission, gross negligence or willful misconduct of, or the exercise of a reserved right by, a Landlord Party and/or Owner, (ii) a liability or obligation of Landlord, Owner or any of their respective Affiliates under any Permitted

Encumbrance, the Development Agreement, or this Lease (including, without limitation, the Scope of Work Document), or (iii) otherwise constitutes an Excluded Claim. If: (a) an attorney is retained to represent Owner in any bankruptcy, reorganization, receivership, or other proceedings affecting creditors' rights and involving a claim by Owner under this Guaranty; or (b) an attorney is retained to represent Owner in any proceedings whatsoever in connection with this Guaranty and Owner prevails in any such proceedings set forth in clauses (a)-(b), above, then Guarantor shall pay to Owner upon demand all reasonable attorney's fees, costs and expenses incurred in connection therewith (to the extent relating to the enforcement of this Guaranty) (all of which are referred to herein as "**Enforcement Costs**"), in addition to all other amounts due hereunder, regardless of whether all or a portion of such Enforcement Costs are incurred in a single proceeding brought to enforce this Guaranty and the Agreement.

5. **GUARANTOR'S WAIVERS.** Guarantor has reviewed and is familiar with the provisions of the Ground Lease, and hereby waives, to the fullest extent now or hereafter not prohibited by applicable law or otherwise required by the Ground Lease, notice of (a) acceptance of this Guaranty, (b) any amendment, modification, supplement, or extension of the Ground Lease, (c) the occurrence of any breach by Ground Lessee of any of the terms or conditions of the Ground Lease, (d) any transfer or disposition of the Guaranteed Obligations, or any part thereof, to any Person acquiring all or a portion of the leasehold estate under the Ground Lease in accordance with the Ground Lease, (e) proof of non-payment or default by Ground Lessee, or (f) all demands and notices of every kind (other than those specifically required under the Ground Lease or this Guaranty). Guarantor further hereby waives (1) any presentment for payment, demand, or protest with respect to this Guaranty, (2) any law, statute, obligation or requirement that purports to require Owner to pursue any collateral securing the Obligations prior to proceeding under this Guaranty, (3) any rights that Guarantor may acquire by way of subrogation or reimbursement under this Guaranty as a result of any payment made hereunder or otherwise, and (4) any right of Guarantor to require that an action be brought against Tenant under the provisions of Title 47, Chapter 12, Tennessee Code Annotated, as the same may be amended from time to time. Notwithstanding the foregoing to the contrary, (i) Guarantor in no events waives the Retained Rights and (ii) nothing herein shall prohibit the payment of any development, construction or other fee or the distribution of insurance proceeds from the Property to Guarantor or any affiliate of Guarantor so long as no terminable Event of Default exists under the Ground Lease and Guarantor is not in default of any of the Obligations beyond applicable notice and grace periods.

6. **GUARANTOR'S WARRANTIES AND COVENANTS.** Guarantor represents and warrants that: (i) this Guaranty and all other documents executed or to be executed by it in connection herewith have been duly authorized and constitute the legal, valid, and binding obligation of Guarantor, enforceable against Guarantor in accordance with their terms, except as enforceability may be limited by applicable bankruptcy, insolvency, reorganization, moratorium or similar laws affecting the enforcement of creditors' rights generally; (ii) [NTD: if Guarantor is an entity:] it is duly organized, validly existing and in good standing under the laws of the state of its formation and is duly authorized and qualified to perform this Guaranty within the State of Tennessee; (iii) neither this Guaranty nor any other document executed or to be executed in connection herewith violates the terms of any other agreement, order, writ, injunction, or decree to which Guarantor is a party; (iv) [NTD: if Guarantor is an entity:] to Guarantors' knowledge, all consents, approvals, orders or authorizations of, or registrations, declarations or filings with, all governmental authorities (collectively, the "**Consents**") that are required in connection with the



valid execution, delivery and performance by Guarantor of this Guaranty have been obtained; (v) no bankruptcy, insolvency, reorganization or similar action or proceeding, whether voluntary or involuntary, is pending, or, to Guarantor's knowledge, has been threatened in writing against Guarantor; (vi) there are no actions, suits, or proceedings at law or at equity, pending or, to Guarantor's best knowledge, threatened against or affecting Guarantor that materially adversely affect the financial condition of Guarantor or the ability of Guarantor to perform any of its obligations under this Guaranty; (vii) as of the Effective Date all [NTD: *applicable if entity:*] financial statements of Guarantor heretofore delivered to Owner are true and correct in all material respects and present the financial condition of Guarantor as of the respective dates thereof, and no materially adverse change has occurred in the financial conditions reflected therein since the respective dates thereof; and (viii) Guarantor is an Affiliate of Tenant and or otherwise has a financial interest in the Premises. Guarantor shall provide prompt written notice to Owner of any litigation or governmental proceedings pending or threatened in writing against Guarantor that is reasonably likely to materially adversely affect Guarantor's ability to perform the Obligations hereunder.

7. **ADDITIONAL, INDEPENDENT AND UNSECURED OBLIGATIONS.** This Guaranty is a continuing guaranty of payment and not of collection and cannot be revoked by Guarantor and shall continue to be effective with respect to any obligation hereof arising or created after any attempted revocation hereof. The obligations of Guarantor hereunder shall be in addition to and shall not limit or in any way affect the obligations of Guarantor under any other existing or future guaranties unless said other guaranties are expressly modified or revoked in writing. Furthermore, the obligations and liabilities Guarantor hereunder shall not be diminished or offset by any payment by Guarantor under any other guaranty, agreement, document or instrument by Guarantor in favor of Owner.

8. **OBLIGATIONS OF GUARANTOR UNCONDITIONAL.** The obligations of Guarantor under this Guaranty shall be continuing, absolute, and unconditional and shall remain in full force and effect without regard to, and shall not be released, discharged, or in any way affected by, (1) any amendment, extension, modification of, or supplement to the Ground Lease; (2) any exercise or nonexercise of or delay in exercising any right, remedy, power, or privilege under or in respect of this Guaranty or the Ground Lease or any waiver, consent, indulgence, or other action or inaction in respect thereof; (3) failure or omission on the part of Owner to enforce any right given under the Ground Lease or this Guaranty or any remedy conferred thereby or hereby, or by any waiver of any term, covenant, agreement or condition of this Guaranty; (4) any bankruptcy, insolvency, arrangement, composition, assignment for the benefit of creditors, or similar proceeding commenced by or against Tenant or Guarantor; (5) dissolution (voluntarily or involuntarily) of Tenant or Guarantor; (6) the genuineness, validity, or enforceability of any provisions of the Ground Lease or this Guaranty; (7) any defense that may arise by reason of the failure of Owner to file or enforce a claim against Tenant or Guarantor in any bankruptcy or other proceeding; (8) the voluntary or involuntary liquidation, dissolution, sale of all or substantially all of the property of Tenant or Guarantor, the marshalling of assets and liabilities, or other similar proceeding affecting Tenant, Guarantor or any of their respective assets; (9) the release of Tenant or Guarantor from the performance or observance of any of the agreements, covenants, terms, or conditions contained in the Ground Lease or this Guaranty by operation of law, except upon payment or performance in full of the Obligations; (10) the release or discharge of any other surety or guarantor from the Obligations; or (11) any other circumstances that might otherwise constitute

a legal or equitable discharge of, or defense available to, a guarantor or surety (other than upon payment or performance in full of the Obligations), it being the purpose and intent of Guarantor that the obligations of Guarantor hereunder shall be absolute and unconditional under any and all circumstances and shall not be discharged except by payment or performance in full of the Obligations as herein provided, and then only to the extent of such payment or performance. In the event that, pursuant to any insolvency, bankruptcy, reorganization, receivership or other debtor relief law, or any judgment, order or decision thereunder, Owner must rescind or restore any payment, or any part thereof, received by Owner in satisfaction of the Obligations, any prior release or discharge from the terms of this Guaranty given to Guarantor by Owner shall be without effect, and this Guaranty shall remain in full force and effect.

9. **CUMULATIVE RIGHTS.** Each and every right, remedy, and power hereby granted to Owner or allowed it by law or other agreement shall be cumulative and not exclusive of any other, and may be exercised by Owner at any time and from time to time.

10. **DEFAULT BY GUARANTOR.** Notwithstanding anything contained in this Guaranty or in the Ground Lease to the contrary, Guarantor shall be in default under this Guaranty if (i) a court makes or enters any decree or order adjudging Guarantor to be bankrupt or insolvent; (ii) a petition in bankruptcy or other insolvency proceedings seeking either liquidation or reorganization of Guarantor or an arrangement under the bankruptcy laws or any other applicable debtor's relief law or statute of the United States or any state thereof is filed against Guarantor and not dismissed within ninety (90) days thereafter; (iii) a receiver, trustee or assignee of Guarantor in bankruptcy or any insolvency proceeding or for its property is appointed and not discharged within ninety (90) days thereafter; (iv) a court made or entered any decree directing the winding up or liquidation of Guarantor and such decree or order shall continue without being vacated or dismissed for a period of ninety (90) days; or (v) Guarantor voluntarily submitted to or filed a petition seeking any such decree or order or relief under any federal or state bankruptcy or insolvency laws. Upon the occurrence of any such default, Owner may, at its option, accelerate the Obligations.

11. **RULES OF CONSTRUCTION.** The term "Person" as used herein shall include any individual, company, trust or other legal entity of any kind whatsoever. When the context and construction so require, all words used in the singular herein shall be deemed to have been used in the plural and vice versa. All headings appearing in this Guaranty are for convenience only and shall be disregarded in construing this Guaranty.

12. **GOVERNING LAW.** This Guaranty and the obligations of Guarantor hereunder shall be construed and enforced in accordance with the laws of the State of Tennessee, excluding any conflicts of law rule or principle which might refer such construction to the laws of another state or country. Guarantor and all persons and entities in any manner obligated to Owner under this Guaranty consent to the jurisdiction of any federal or local court within Davidson County, Tennessee having proper venue and also consent to service of process by any means authorized by the State of Tennessee.

13. **MISCELLANEOUS.** Guarantor may not, without the prior written consent of Owner, assign any of its rights, powers, duties, or obligations under this Guaranty, provided that Owner shall not unreasonably withhold consent of an assignment made pursuant to the terms of

Section 18.2(c) of the Ground Lease. The provisions of this Guaranty will bind and benefit the heirs, executors, administrators, legal representatives, nominees, successors and permitted assigns of Guarantor. Guarantor acknowledges that its obligations under this Guaranty are unconditional. The liability of all persons and entities who are in any manner obligated hereunder as Guarantor shall be joint and several. If any provision of this Guaranty shall be determined by a court of competent jurisdiction to be invalid, illegal or unenforceable, that portion shall be deemed severed from this Guaranty and the remaining parts shall remain in full force as though the invalid, illegal or unenforceable portion had never been part of this Guaranty.

14. **ENFORCEABILITY.** Guarantor hereby acknowledges that: (a) the obligations undertaken by Guarantor in this Guaranty are complex in nature, and (b) numerous possible defenses to the enforceability of these obligations may presently exist and/or may arise hereafter, and (c) as part of Owner's consideration for entering into this transaction, Owner has specifically bargained for the waiver and relinquishment by Guarantor of all such defenses (other than Retained Rights), and (d) Guarantor has had the opportunity to seek and receive legal advice from skilled legal counsel in the area of financial transactions of the type contemplated herein. Given all of the above, Guarantor each does hereby represent and confirm to Owner that it is fully informed regarding, and that it does thoroughly understand: (i) the nature of all such possible defenses, and (ii) the circumstances under which such defenses may arise, and (iii) the benefits which such defenses might confer upon Guarantor, and (iv) the legal consequences to Guarantor of waiving such defenses. Guarantor acknowledges that it makes this Guaranty with the intent that this Guaranty and all of the informed waivers herein shall each and all be fully enforceable by Owner, and that Owner is induced to enter into this transaction in material reliance upon the presumed full enforceability thereof.

15. **WAIVER OF RIGHT TO TRIAL BY JURY.** EACH PARTY TO THIS GUARANTY, AND BY ITS ACCEPTANCE HEREOF, OWNER, HEREBY EXPRESSLY WAIVES ANY RIGHT TO TRIAL BY JURY OF ANY CLAIM, DEMAND, ACTION OR CAUSE OF ACTION (a) ARISING UNDER THIS GUARANTY AND ANY FUTURE MODIFICATION THEREOF OR (b) IN ANY WAY CONNECTED WITH OR RELATED OR INCIDENTAL TO THE DEALINGS OF THE PARTIES HERETO OR ANY OF THEM WITH RESPECT TO THIS GUARANTY (AS NOW OR HEREAFTER MODIFIED) OR ANY OTHER INSTRUMENT, DOCUMENT OR AGREEMENT EXECUTED OR DELIVERED IN CONNECTION HERewith, OR THE TRANSACTIONS RELATED HERETO OR THERETO, IN EACH CASE WHETHER NOW EXISTING OR HEREAFTER ARISING, AND WHETHER SOUNDING IN CONTRACT OR TORT OR OTHERWISE; AND EACH PARTY AND OWNER HEREBY AGREES AND CONSENTS THAT ANY PARTY TO THIS GUARANTY AND OWNER MAY FILE AN ORIGINAL COUNTERPART OR A COPY OF THIS SECTION WITH ANY COURT AS WRITTEN EVIDENCE OF THE CONSENT OF THE PARTIES HERETO AND OWNER TO THE WAIVER OF THEIR RIGHT TO TRIAL BY JURY.

16. **NOTICES.** Any notices or other documents required or permitted to be given under the terms of this Guaranty shall be delivered (a) by hand, (b) sent by nationally recognized overnight delivery service, such as Federal Express, with provision for receipt, or (c) by registered or certified mail, return receipt requested, or (d) sent by electronic mail (provided a notice is also

sent by one of the methods set forth in the preceding clauses (a)-(c)), addressed to the parties as follows:

If to Owner:

THE METROPOLITAN GOVERNMENT OF NASHVILLE  
AND DAVIDSON COUNTY  
Metropolitan Courthouse  
1 Public Square  
Nashville, Tennessee 37201  
Attention: Chief Development Officer  
Email: Bob.Mendes@nashville.gov

with copies to:

Metropolitan Department of Law  
1 Public Square, Suite 108  
Nashville, Tennessee 37201  
Attention.: Department of Law  
Email: tom.cross@nashville.gov

If to Guarantor:

[ \_\_\_\_\_ ]  
c/o The Fallon Company LLC  
1222 Demonbreun Street, Suite 1210  
Nashville, Tennessee  
Attention: Benjamin Farrer  
Email: bfarrer@falloncompany.com

With a copy to:

The Fallon Company LLC  
ONE Marina Park Drive, 14th Floor  
Boston, Massachusetts 02101  
Attention: Brian M. Awe  
Email: bawe@falloncompany.com

DLA Piper LLP (US)  
33 Arch Street, 26<sup>th</sup> Floor  
Boston, Massachusetts 02210  
Attention: John E. Rattigan Jr., Esq.  
Oriana R. Montani, Esq.  
Email: john.rattigan@us.dlapiper.com  
oriana.montani@us.dlapiper.com

or to such other address as shall be specified by like notice.

17. **RELEASE OF GUARANTOR.** Notwithstanding any other provision of this Guaranty to the contrary, this Guaranty shall terminate upon the full satisfaction of all of the following: (i) the full payment and performance of the Obligations, as evidenced by Substantial Completion of the Project in accordance with the terms of the Ground Lease or as otherwise agreed in writing by Owner, and (ii) the payment in full of all Enforcement Costs, if any. Upon satisfaction of the requirements set forth in the preceding sentence, this Guaranty shall be automatically released in its entirety of no further force and effect, and Guarantor shall automatically and without further act of any party be released and discharged from all liability under this Guaranty.

18. **ENTIRE AGREEMENT; AMENDMENT.** This Guaranty is the entire agreement between the parties hereto with respect to the subject matter hereof, and supersedes and replaces all prior discussions, representations, communications and agreements (oral or written). This Guaranty may only be amended or terminated by an instrument in writing executed by Owner and Guarantor.

19. **COUNTERPARTS.** This Guaranty may be executed in one or more counterparts, and/or by execution of counterpart signature pages which may be attached to one or more counterpart, each of which, when taken together, shall constitute one and the same document. In addition, any counterpart signature page may be executed by any party wherever such party is located, and may be delivered by telephone facsimile or e-mail transmission, and any such facsimile or e-mail transmitted signature pages may be attached to one or more counterparts of this Guaranty, and such faxed or e-mailed signature(s) shall have the same force and effect, and be as binding, as original signatures executed and delivered in person.

[SIGNATURES ON FOLLOWING PAGE]

IN WITNESS WHEREOF, Guarantor has executed this Guaranty as of the date appearing on the first page of this Guaranty.

GUARANTOR:

---

**Exhibit H**

Development Master Plan

37384210.1

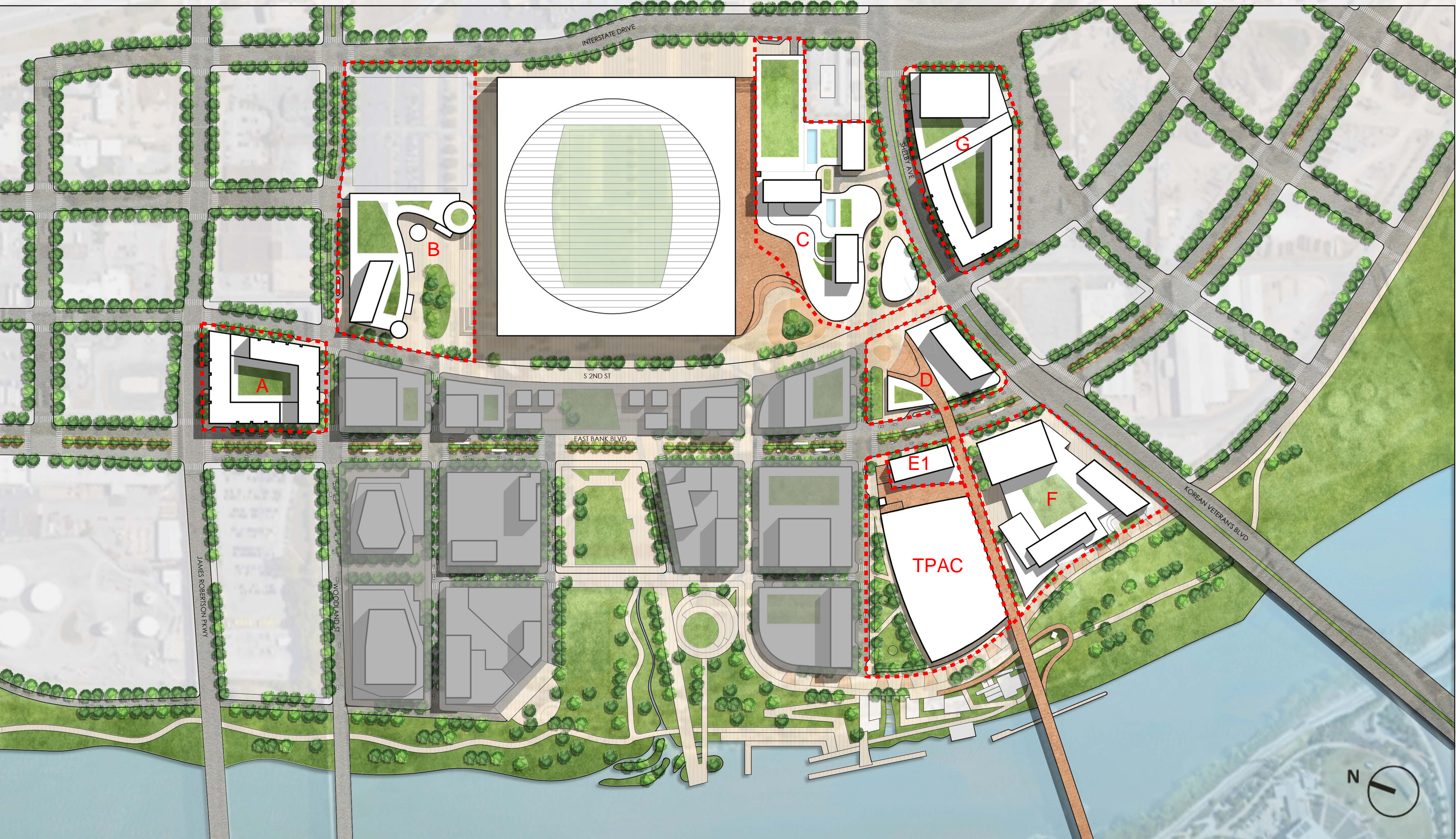

**IDA MASTER PLAN**  
February 5, 2023

DRAFT

DRAFT



**Exhibit I**

Form of Memorandum of Agreement

37016470.21

This Instrument Prepared by:  
Bradley, Arant, Boult, Cummings, LLP (JTT)  
1600 Division Street, Suite 700  
P. O. Box 340025  
Nashville, Tennessee 37203

### **MEMORANDUM OF AGREEMENT**

THIS MEMORANDUM OF AGREEMENT (“Memorandum”) is made and entered into this \_\_\_ day of \_\_\_\_\_, 2024, by and between THE METROPOLITAN GOVERNMENT OF NASHVILLE AND DAVIDSON COUNTY, whose address is Metropolitan Courthouse, 1 Public Square, Nashville, Tennessee 37201 (the “Owner”), and TFC NASHVILLE DEVELOPMENT LLC, a Delaware limited liability company, whose address is 1222 Demonbreun St., Suite 1210, Nashville, Tennessee 37203 (the “Developer”).

Owner and the Developer entered into that certain Master Development Agreement dated as of the date hereof (the “Agreement”). Capitalized terms used herein and not otherwise defined shall be defined as provided in the Agreement. The Parties hereby give notice of the existence of the Agreement and of the rights and benefits granted to, and certain obligations imposed upon, providing, among other things, that Developer has certain rights to develop certain parcels of land owned by the Owner as shown on Exhibit A ( the “IDA Land”) subject to and in accordance with the terms and conditions of the Agreement.

This Memorandum is subject to all of the terms and conditions set forth in the Agreement, which are incorporated herein by reference and made a part hereof, as fully as though copied verbatim herein. In the event of a conflict between this Memorandum and the Agreement, the Agreement shall prevail.

This Memorandum may be executed in two or more counterparts, each of which shall be deemed to be an original, but all of which shall constitute one and the same instrument, and in making proof of this Memorandum, it shall not be necessary to produce or account for more than one such counterpart.

[Remainder of page intentionally left blank]

IN WITNESS WHEREOF, the parties have hereunto set their hands and seals as of the day and date first above written.

ATTEST:

\_\_\_\_\_  
Name: \_\_\_\_\_  
Title: \_\_\_\_\_

\_\_\_\_\_  
By: \_\_\_\_\_  
Name: \_\_\_\_\_  
Title: \_\_\_\_\_

\_\_\_\_\_  
By: \_\_\_\_\_  
Name: \_\_\_\_\_  
Title: \_\_\_\_\_

STATE OF

COUNTY OF

Personally appeared before me, \_\_\_\_\_, Notary Public, \_\_\_\_\_, with whom I am personally acquainted (or proved to me on the basis of satisfactory evidence), and who acknowledged that he/she executed the foregoing instrument for the purposes therein contained and who further acknowledged that he/she is the \_\_\_\_\_, of \_\_\_\_\_, a \_\_\_\_\_, the within named bargainer and that he/she is authorized to execute this instrument on behalf of said corporation.

WITNESS my hand, at office, this \_\_\_\_ day of \_\_\_\_\_, \_\_\_\_\_.

\_\_\_\_\_  
Notary Public

My Commission Expires: \_\_\_\_\_

STATE OF

COUNTY OF

Personally appeared before me, \_\_\_\_\_, Notary Public, \_\_\_\_\_, with whom I am personally acquainted (or proved to me on the basis of satisfactory evidence), and who acknowledged that he/she executed the foregoing instrument for the purposes therein contained and who further acknowledged that he/she is the \_\_\_\_\_, of \_\_\_\_\_, a \_\_\_\_\_, the within named bargainer and that he/she is authorized to execute this instrument on behalf of said corporation.

WITNESS my hand, at office, this \_\_\_\_ day of \_\_\_\_\_, \_\_\_\_\_.

\_\_\_\_\_  
Notary Public

My Commission Expires: \_\_\_\_\_

STATE OF \_\_\_\_\_

COUNTY OF \_\_\_\_\_

Personally appeared before me, \_\_\_\_\_, Notary Public,  
\_\_\_\_\_, with whom I am personally acquainted (or proved to me on the  
basis of satisfactory evidence), and who acknowledged that he/she executed the foregoing  
instrument for the purposes therein contained and who further acknowledged that he is the  
\_\_\_\_\_ of \_\_\_\_\_, a \_\_\_\_\_,  
and that he is authorized to execute this instrument as on behalf of said limited liability company  
as such \_\_\_\_\_.

WITNESS my hand, at office, this \_\_\_\_ day of \_\_\_\_\_, \_\_\_\_\_.

\_\_\_\_\_  
Notary Public

\_\_\_\_\_  
My Commission Expires

**EXHIBIT A**

**CAMPUS OPERATIONS AND USE AGREEMENT**

**by and among**

**TFC NASHVILLE DEVELOPMENT LLC**

**and**

**TENNESSEE STADIUM, LLC**

**and**

**THE METROPOLITAN GOVERNMENT OF NASHVILLE AND DAVIDSON COUNTY**

**Dated \_\_\_\_\_, 2024**

## TABLE OF CONTENTS

	<b>Page</b>
ARTICLE 1 GENERAL TERMS.....	3
Section 1.1    Definitions and Usage.....	3
Section 1.2    IDA Developer’s Rights and Obligations.....	3
Section 1.3    IDA Developer’s Assignment of Specific Rights and Obligations to IDA Ground Tenant.....	3
ARTICLE 2 REPRESENTATIVES OF THE PARTIES.....	5
Section 2.1    Metro Representatives .....	5
Section 2.2    StadCo Representative.....	5
Section 2.3    IDA Developer Representative.....	5
ARTICLE 3 TERM.....	6
Section 3.1    Term.....	6
Section 3.2    Extension of COUA Term .....	6
ARTICLE 4 REPRESENTATIONS.....	6
Section 4.1    Representations and Warranties of Metro .....	6
Section 4.2    Representations and Warranties of the IDA Developer .....	7
Section 4.3    Representations and Warranties of StadCo .....	8
ARTICLE 5 GENERAL CAMPUS COORDINATION PROVISIONS; CAMPUS COORDINATION COMMITTEE .....	9
Section 5.1    General Considerations.....	9
Section 5.2    Formation of Campus Coordination Committee .....	10
Section 5.3    Purpose .....	10
Section 5.4    Campus Coordination Meetings and Procedures.....	10
Section 5.5    Authority.....	13
Section 5.6    Dispute Resolution.....	13
ARTICLE 6 EVENT PLANNING AND COORDINATION.....	13
Section 6.1    General Considerations.....	13
Section 6.2    Master Calendar.....	13
Section 6.3    Designation of Plaza Events.....	13
Section 6.4    Plaza Event User Fees; Plaza Event Operating Costs .....	16
Section 6.5    Plaza Event Operating Plan .....	16
Section 6.6    Special Stadium Events .....	17
ARTICLE 7 CAMPUS USE AND OPERATIONS.....	17
Section 7.1    Second Street Plaza.....	17
Section 7.2    Data Rights .....	18
Section 7.3    Commercial Rights.....	18
Section 7.4    Digital Experiences and Assets .....	19
Section 7.5    Integration of Technology .....	19



Section 7.6	Advertising Limitations .....	19
Section 7.7	Second Street Plaza Naming Rights .....	21
Section 7.8	Campus Sponsors .....	21
Section 7.9	Sports Betting and Casinos.....	22
Section 7.10	Construction Management Agreement.....	22
ARTICLE 8 CAMPUS ACCESS .....		23
Section 8.1	Access Management .....	23
Section 8.2	Traffic Plan .....	23
Section 8.3	Temporary Street Closure.....	24
ARTICLE 9 DEFAULTS AND REMEDIES.....		24
Section 9.1	Events of Default and Remedies.....	24
Section 9.2	Remedies.....	25
ARTICLE 10 STANDARDS FOR APPROVALS .....		25
Section 10.1	Review and Approval Rights.....	25
Section 10.2	Standard for Review .....	25
Section 10.3	Resubmissions .....	26
Section 10.4	Duties, Obligations, and Responsibilities Not Affected.....	26
ARTICLE 11 DISPUTE RESOLUTION PROCEDURES .....		26
Section 11.1	Intent .....	26
Section 11.2	Resolution Procedure.....	27
ARTICLE 12 MISCELLANEOUS PROVISIONS.....		28
Section 12.1	Notices .....	28
Section 12.2	Amendment.....	30
Section 12.3	Waivers .....	30
Section 12.4	Counterparts.....	30
Section 12.5	Knowledge.....	30
Section 12.6	Drafting.....	30
Section 12.7	No Third-Party Beneficiaries.....	30
Section 12.8	Entire Understanding.....	30
Section 12.9	Governing Law, Venue; Waiver of Jury.....	31
Section 12.10	Time is of the Essence .....	32
Section 12.11	Severability .....	32
Section 12.12	Relationship of the Parties .....	32
Section 12.13	Further Assurances/Additional Documents and Approval .....	32
Section 12.14	Recording.....	32
Section 12.15	Estoppel Certificate .....	32
Section 12.16	Limitation of Liability .....	33
Section 12.17	Runs with the Land.....	33
Section 12.18	Reserved .....	33
Section 12.19	Prohibition Against Boycotting Israel. ....	33
Section 12.20	Public Records.....	33
Section 12.21	Permitted Assignment by Metro.....	34

Section 12.22 Metro’s Rights as Sovereign.....	34
Section 12.23 Permitted Assignment by StadCo.....	34
Section 12.24 Permitted Assignment by IDA Developer.....	34

EXHIBITS:

EXHIBIT A:	Glossary of Defined Terms and Rules of Usage
EXHIBIT B:	Campus Property
EXHIBIT C:	Stadium Site
EXHIBIT D:	Existing Stadium Site
EXHIBIT E:	Initial Development Area
EXHIBIT F:	Location of Second Street Plaza Site
EXHIBIT G:	Location of Parcel B Easement Area

## CAMPUS OPERATIONS AND USE AGREEMENT

THIS CAMPUS OPERATIONS AND USE AGREEMENT (this “Agreement”) is made as of \_\_\_\_\_, 2024 (the “Effective Date”), by and among **TFC NASHVILLE DEVELOPMENT LLC**, a Delaware limited liability company (“IDA Developer”), **TENNESSEE STADIUM, LLC**, a Delaware limited liability company (“StadCo”) and **THE METROPOLITAN GOVERNMENT OF NASHVILLE AND DAVIDSON COUNTY** (“Metro”). IDA Developer, StadCo and Metro collectively are referred to herein as the “Parties” and individually as a “Party.”

### RECITALS

WHEREAS, the Sports Authority of The Metropolitan Government of Nashville and Davidson County (the “Authority”) and Metro own the approximately 95-acres of property located on the East Bank along the Cumberland River (the “Campus”), as described in **Exhibit B**;

WHEREAS, the entirety of the Campus was previously owned by the Authority and leased by the Authority to Cumberland Stadium, Inc., a Delaware corporation and successor to Cumberland Stadium, LP, a Tennessee limited partnership (“Cumberland”), an affiliate of StadCo and the National Football League’s (the “NFL’s”) Tennessee Titans, operating as Tennessee Football, LLC (the “Team”), pursuant to that certain Stadium Lease, dated as of May 14, 1996, as amended, between the Authority, as lessor, and Cumberland, as lessee (the “Existing Lease”), and the Campus is the home to a multi-purpose outdoor stadium currently known as Nissan Stadium (the “Existing Stadium”) and surface parking for the Existing Stadium;

WHEREAS, in connection with the anticipated development and construction of a new, first-class, state-of-the-art, enclosed venue for professional football and numerous other sporting, entertainment, cultural and civic events (the “Stadium”) to be located on an approximately 20-acre site on the Campus as generally depicted and described on **Exhibit C** (the “Stadium Site”): (i) the Authority and Cumberland further amended the Existing Lease to reduce the leased premises subject thereto to that property described in **Exhibit D** (the “Existing Stadium Site”); (ii) the Authority conveyed fee title to the entirety of the Campus, other than the Existing Stadium Site, to Metro; (iii) the Authority granted Metro an option to purchase the Existing Stadium Site upon the expiration of the Existing Lease, all such that Metro will ultimately hold fee title to the entirety of the Campus; (iv) Metro and the Authority entered into that certain Ground Lease dated as of August 25, 2023, whereby Metro, as lessor, will ground lease the Stadium Site to the Authority, as lessee; (v) the Authority and StadCo, entered into that certain Development and Funding Agreement dated as of August 25, 2023 (the “Stadium Development Agreement”), providing for the financing, development and construction of the Stadium on the Stadium Site, and the rights and responsibilities of the Authority and StadCo related thereto; and (vi) the Authority and StadCo entered into that certain Stadium Lease Agreement dated as of August 25, 2023 (the “Stadium Lease”), providing for the lease of the Stadium, once completed, by the Authority, as sublessor, to StadCo, as sublessee, and including matters relating to the use, occupancy, operation, maintenance and repair of the Stadium and certain other matters collateral thereto;

WHEREAS, Metro, the Authority and StadCo entered into that certain Site Coordination Agreement dated as of August 25, 2023 (the “Original SCA”), to set forth certain agreements with

respect to (A) the provision and maintenance of parking facilities for the benefit of the Stadium and, while it remains in operation, the Existing Stadium, (B) the development, design, construction and operation of the Campus at the direction of Metro, and the coordination thereof with the construction of the Stadium and related improvements , and (C) the respective rights and obligations of Metro, the Authority and StadCo with respect to the use and operation of the Campus;

WHEREAS, Metro has engaged the IDA Developer to develop those portions of the Campus identified on **Exhibit E** as the “initial development area” (the “**Initial Development Area**”), and Metro and IDA Developer have entered into that certain Master Development Agreement dated as of \_\_\_\_\_, 2024 (the “**IDA Development Agreement**”), whereby IDA Developer and/or one or more IDA Ground Tenants will develop the Initial Development Area, as applicable, pursuant to the IDA Development Agreement and one or more long-term ground leases to be entered into as provided in the IDA Development Agreement (each, as it may be amended from time to time in accordance with its terms, an “**IDA Ground Lease**”);

WHEREAS, within the Initial Development Area, there are parcels generally identified on **Exhibit E** as Parcel B (“**IDA Parcel B**”), Parcel C (“**IDA Parcel C**”) and Parcel D (“**IDA Parcel D**”), the final boundaries to which will be established pursuant to the IDA Development Agreement;

WHEREAS, adjacent to IDA Parcel C and the Stadium Site, there is an area designated on **Exhibit F** as the Second Street Plaza (the “**Second Street Plaza Site**”), the final boundaries of which will be established pursuant to the Declaration (defined below), that is excluded from the Initial Development Area and will be designed and constructed by StadCo as an open air plaza (the “**Second Street Plaza**”) pursuant to the Stadium Development Agreement;

WHEREAS, to set forth certain agreements regarding the Parties’ respective rights and obligations relative to the operation and use of the Initial Development Area and the Second Street Plaza (i) the Parties are executing and entering into this Agreement, and (ii) Metro has executed and recorded that certain Declaration of Easements, Restrictions and Covenants for the Stadium Plaza, Parcels B and C, East Bank, dated as of \_\_\_\_\_, 2024 (the “**Declaration**”);

WHEREAS, adjacent to IDA Parcel B and the Stadium Site, there is an area designated on **Exhibit G** as the Parcel B Easement Area (the “**Parcel B Easement Area**”), the final boundaries of which will be established pursuant to the Declaration, upon which area the Declaration will create certain easements for encroachment, access and use for the benefit of StadCo;

WHEREAS, Metro and StadCo have executed that certain First Amended and Restated Site Coordination Agreement dated as of even date herewith (the “**First Amended SCA**”) to reflect, among other things, that the rights and responsibilities of the IDA Developer and tenants under the IDA Ground Leases with respect to the subject matter of the Original SCA are no longer set forth therein but are instead set forth exclusively in this Agreement.

NOW, THEREFORE, in consideration of the foregoing Recitals, which are hereby incorporated into this Agreement, and the mutual premises, undertakings, and covenants hereinafter set forth, and intending to be legally bound hereby, the Parties agree as follows:

## AGREEMENT

### ARTICLE 1 GENERAL TERMS

Section 1.1 Definitions and Usage. Capitalized terms used in this Agreement shall have the meanings assigned to them in Exhibit A, which also contains rules as to usage applicable to this Agreement, or within the individual sections of this Agreement.

Section 1.2 IDA Developer's Rights and Obligations. Any rights or obligations of the IDA Developer contained in this Agreement specific to the facilities upon, and business activities conducted upon, a particular parcel shall only commence for any such parcel upon the execution of the IDA Ground Lease for such parcel. Pending such execution, Metro shall have such obligations. For avoidance of doubt, from and after the Execution Date, IDA Developer shall have all other rights and obligations described herein as those of IDA Developer, including without limitation those set forth in Articles 5, 6 and 8.

Section 1.3 IDA Developer's Assignment of Specific Rights and Obligations to IDA Ground Tenant

(a) Organization. Upon execution of each IDA Ground Lease, Metro shall assign the rights and obligations under this Agreement specific to the facilities upon, and business activities conducted upon, the applicable parcel (an "IDA Parcel") to the IDA Ground Tenant under such IDA Ground Lease, and shall cause such IDA Ground Tenant (other than IDA Developer) to execute a joinder agreement relating to, and assuming, all obligations of Metro and the IDA Developer hereunder specific to the facilities upon, and business activities conducted upon, the subject IDA Parcel (excluding, unless specifically provided in a joinder agreement, the obligations of the IDA Developer set forth in Articles 5, 6 and 8). Thereafter, such IDA Ground Tenant shall be a Party to this Agreement and shall be solely responsible for the compliance of such IDA Parcel with the obligations under this Agreement specific to the facilities upon, and business activities conducted upon, the subject IDA Parcel, and Metro and the IDA Developer shall thereafter have no responsibility or liability for such compliance with respect to the obligations assigned to the IDA Ground Tenant for such IDA Parcel; provided, upon the expiration or any earlier termination of any IDA Ground Lease, the rights and obligations specific to the facilities upon, and business activities conducted upon, such IDA Parcel shall revert to Metro; provided however, Metro shall not have any liability for any noncompliance with any obligations by the IDA Ground Tenant that occur prior to the expiration or any earlier termination of any IDA Ground Lease; and provided, further, Metro shall reasonably cooperate with StadCo to enforce the obligations of such IDA Ground Tenant under this Agreement. Upon assignment of an IDA Ground Tenant's interest under any IDA Ground Lease to an assignee (an "IDA Ground Tenant Assignee"), the IDA Ground Tenant shall assign the rights and obligations under this Agreement specific to the facilities upon, and activities conducted upon, the subject IDA Parcel to such IDA Ground Tenant Assignee, and shall cause such IDA Ground Tenant Assignee to execute a joinder agreement (in form and substance acceptable to Metro) relating to, and assuming, all obligations of the IDA Ground Tenant hereunder specific to the facilities upon, and business activities conducted upon, the subject IDA Parcel. Thereafter, such IDA Ground Tenant Assignee shall be a Party to this Agreement and shall be solely responsible for the compliance of such IDA Parcel

with the obligations under this Agreement specific to the facilities upon, and business activities conducted upon, the subject IDA Parcel (and shall be deemed to constitute an IDA Ground Tenant for purposes of this Agreement), and the assigning IDA Ground Tenant shall thereafter have no responsibility for such compliance with respect to such IDA Parcel. Neither the IDA Developer, nor the IDA Ground Tenant nor the IDA Ground Tenant Assignee shall be responsible for the compliance or non-compliance of any IDA Parcel, except for the one which is the subject of its IDA Ground Lease, with the terms of this Agreement. Upon entering into an IDA Ground Lease (and the joinder described above), Metro shall notify StadCo of such IDA Ground Lease, which notice will identify the applicable IDA Parcel and the name, contact information and notice address of the IDA Ground Tenant, and thereafter such IDA Ground Tenant will be entitled to receive all notices under this Agreement which affect its IDA Parcel. Upon each assignment to an IDA Ground Tenant Assignee (and such IDA Ground Tenant Assignee's entry into the joinder described above), the IDA Ground Tenant shall notify Metro and StadCo of such assignment, which notice will identify the applicable IDA Parcel and the name, contact information and notice address of the IDA Ground Tenant Assignee, and thereafter such IDA Ground Tenant Assignee will be entitled to receive all notices under this agreement which affect its IDA Parcel. Upon reversion to the landlord under any IDA Ground Lease of the rights and obligations hereunder specific to the facilities upon, and business activities conducted upon, an IDA Parcel, Metro shall notify StadCo of such reversion, which notice will identify the applicable IDA Parcel.

(b) Common Areas. IDA Developer may create an entity to maintain and operate certain of the common areas in the Initial Development Area or within the public realm ("Common Areas") on behalf of the individual IDA Ground Tenants. This Common Area Entity ("CAE") shall have the right and ability under its governing documents to assess the ground tenants for the expenses of managing and operating the Common Areas and the right and ability to impose liens on the building parcels for non-payments of such assessments. The CAE may own or lease portions of the Common Areas, and the IDA Developer and its individual IDA Ground Tenants may convey or assign such lessee's rights with respect to any such Common Areas. Upon such conveyance or assignment, the IDA Developer or the applicable IDA Ground Tenant, as applicable, shall cause such CAE to execute a joinder agreement relating to, and assuming, all obligations of the IDA Developer or such IDA Ground Tenant, as applicable, hereunder with respect to the subject Common Area. From and after any such conveyance or assignment of any Common Areas or public realm maintenance obligations, the CAE, and not the IDA Developer or the applicable IDA Ground Tenants or IDA Ground Tenant Assignees, shall be responsible for the maintenance and operation obligations under this Agreement with respect to such areas; provided, the applicable IDA Ground Tenants or IDA Ground Tenant Assignees shall reasonably cooperate with StadCo to enforce the obligations of such CAE under this Agreement. The obligation of the applicable IDA Ground Tenants with respect to maintenance and operations will be limited to their obligations to contribute to the costs of undertaking such maintenance or performing such obligations under the terms of the CAE's organizational documents. Upon any such conveyance or assignment of rights with respect to such Common Areas, the IDA Ground Tenant and IDA Developer shall notify Metro and StadCo of such assignment or conveyance, which notice will identify the applicable Common Area and the name, contact information and notice address of the CAE. Notwithstanding anything in this Section 1.3(b) to the contrary, the creation of the CAE and any assignment, conveyance or other transfer of any rights to any such CAE shall in all respects be subject to Metro's prior written approval which Metro may grant or withhold in Metro's sole

and exclusive discretion, and nothing herein shall be deemed or construed as Metro's consent or approval thereto.

(c) Nothing in this Section 1.3 is intended to relieve the IDA Developer from its responsibilities as a participant of the CCC, and to participate in the matters described in Articles 5, 6 and 8 of this Agreement.

## **REPRESENTATIVES OF THE PARTIES**

Section 2.1 Metro Representatives. Metro hereby designates the Metropolitan Mayor (or such other persons as the Metropolitan Mayor may designate in writing from time to time) to be its authorized representative pursuant to this Agreement (the "Metro Representative"). Any written Approval, decision, confirmation or determination of the Metro Representative shall be binding on Metro, except in those instances in which this Agreement specifically provides for the Approval, decision, confirmation or determination of the Metro Council; *provided, however*, that notwithstanding anything in this Agreement to the contrary, the Metro Representative shall not have any right to modify, amend or terminate this Agreement, and in all cases Section 12.22 shall apply.

Section 2.2 StadCo Representative. StadCo hereby designates the Chief Operating Officer of StadCo to be the representative of StadCo (the "StadCo Representative"), and shall have the right, from time to time, to change the individual who is the StadCo Representative by giving at least ten (10) days' prior written Notice to Metro and the IDA Developer thereof. With respect to any action, decision or determination to be taken or made by StadCo under this Agreement, the StadCo Representative shall take such action or make such decision or determination or shall notify Metro and the IDA Developer in writing of the Person(s) responsible for such action, decision or determination and shall forward any communications and documentation to such Person(s) for response or action. Any written Approval, decision, confirmation or determination hereunder by the StadCo Representative shall be binding on StadCo; *provided, however*, that notwithstanding anything in this Agreement to the contrary, the StadCo Representative shall not have any right to modify, amend or terminate this Agreement.

Section 2.3 IDA Developer Representative. IDA Developer hereby designates the President of the IDA Developer to be the representative of the IDA Developer (the "IDA Developer Representative"), and shall have the right, from time to time, to change the individual who is the IDA Developer Representative by giving at least ten (10) days' prior written Notice to Metro and StadCo thereof. With respect to any action, decision or determination to be taken or made by the IDA Developer under this Agreement, the IDA Developer Representative shall take such action or make such decision or determination or shall notify Metro and StadCo in writing of the Person(s) responsible for such action, decision or determination and shall forward any communications and documentation to such Person(s) for response or action. Any written Approval, decision, confirmation or determination hereunder by the IDA Developer Representative (acting solely in his or her capacity as the IDA Developer Representative) shall be binding on the IDA Developer; *provided, however*, that notwithstanding anything in this Agreement to the contrary, the IDA Developer Representative shall not have any right to modify, amend or terminate this Agreement.



### ARTICLE 3 TERM

Section 3.1 Term. The term of this Agreement (the “COUA Term”) shall commence on the Effective Date and continue thereafter for so long as both (i) the IDA Development Agreement or any IDA Ground Lease is in effect, and (ii) the Stadium Lease is in effect; provided that the COUA Term may be extended at the option of Metro exercised in its sole discretion in the manner described in Section 3.2 below. Notwithstanding the expiration of the COUA Term or the earlier termination of this Agreement, those rights and obligations of the Parties that are expressly described in this Agreement as surviving the expiration or termination of this Agreement shall accordingly survive.

Section 3.2 Extension of COUA Term. If this Agreement would otherwise terminate due to expiration or earlier termination of the Stadium Lease and Metro does not provide notice prior to the expiration or earlier termination of the Stadium Lease to the IDA Developer and each IDA Ground Tenant that Metro intends for the Stadium to cease being used as a venue for sporting, entertainment, cultural and/or civic events, then this Agreement shall be automatically renewed and the COUA Term shall be automatically extended until such time as the Stadium is no longer intended to be used for such purposes or Metro elects, by written notice to IDA Developer and each IDA Ground Tenant, to terminate this Agreement, whichever is earlier, and all of StadCo’s rights, title and interests (but none of its obligations or liabilities arising prior to the expiration or earlier termination of the Stadium Lease) under this Agreement (collectively, the “Stadium Rights”) shall automatically vest in Metro. The Parties specifically intend that there shall not be a merger of any of the Stadium Rights with the title or other interest of Metro in any of the Campus, and the interest of Metro in and to the Stadium Rights and the title or other interest of Metro in the Campus shall remain at all times separate and distinct. Metro shall have the right to assign all or any portion of the Stadium Rights to any subsequent tenants, licensees or other occupants of the Stadium so long as this Agreement remains in effect.

### ARTICLE 4 REPRESENTATIONS

Section 4.1 Representations and Warranties of Metro. Metro represents and warrants to StadCo and the IDA Developer, as of the Effective Date (unless otherwise expressly provided herein), as follows:

(a) Organization. Metro is a public corporation established by Charter adopted by referendum vote on June 28, 1962, in conformity with the laws of the State.

(b) Authorization. Metro has the full right, power, and authority to execute and deliver this Agreement and to perform and satisfy its obligations and duties hereunder. The execution, delivery, and performance of this Agreement by Metro has been duly and fully authorized and approved by all necessary and appropriate action, and a true, complete, and certified copy of the authorizing resolution have been delivered to StadCo and the IDA Developer. This Agreement has been duly executed and delivered by Metro. The individuals executing and delivering this Agreement on behalf of Metro have all requisite power and authority to execute and deliver the same and to bind Metro hereunder.

(c) Binding Obligation and Enforcement. Assuming execution of this Agreement by StadCo and the IDA Developer, this Agreement constitutes legal, valid, and binding obligations of Metro, enforceable against Metro in accordance with its terms.

(d) Governing Documents. The execution, delivery, and performance of this Agreement by Metro does not and will not result in or cause a violation or breach of, or conflict with, any provision of Metro's governing documents or rules, policies or regulations applicable to Metro.

(e) Law. The execution, delivery, and performance of this Agreement by the Metro does not and will not result in or cause a violation or breach of, or conflict with, Applicable Laws applicable to Metro or any of its respective properties or assets which will have a material adverse effect on Metro's ability to perform and satisfy its obligations and duties hereunder. All actions and determinations required to be taken or made by Metro prior to the Effective Date have been taken or made.

(f) Contracts; No Conflict. The execution, delivery, and performance of this Agreement by Metro does not and will not result in or cause a violation or breach of, conflict with, constitute a default under, require any consent, approval, waiver, amendment, authorization, notice or filing under any agreement, contract, understanding, instrument, mortgage, lease, indenture, document or other obligation to which Metro is a party or by which Metro or any of its properties or assets are bound which will have a material adverse effect on Metro's ability to perform and satisfy its obligations and duties hereunder.

(g) Absence of Litigation. There is no action, suit, proceeding, claim, arbitration or investigation pending or, to Metro's knowledge, threatened by any Person, against Metro or its assets or properties which if unfavorably determined Metro would have a material adverse effect on Metro's ability to perform and satisfy its obligations and duties hereunder.

Section 4.2 Representations and Warranties of the IDA Developer. IDA Developer represents and warrants to StadCo and Metro, as of the Effective Date (unless otherwise expressly provided herein), as follows:

(a) Organization. IDA Developer is a Delaware limited liability company duly organized, validly existing, and in good standing under the laws of the State of Delaware and duly authorized to do business in the State of Tennessee. IDA Developer possesses full and adequate power and authority to own, operate, and lease its properties, and to carry on and conduct its business as it is currently being conducted.

(b) Authorization. IDA Developer has the full right, power, and authority to execute and deliver this Agreement and to perform and satisfy its obligations and duties hereunder. The execution, delivery, and performance of this Agreement by IDA Developer has been duly and fully authorized and approved by all necessary and appropriate action, and a true, complete, and certified copies of the authorizing resolutions have been delivered to StadCo and Metro. This Agreement has been duly executed and delivered by IDA Developer. The individual executing and delivering this Agreement on behalf of IDA Developer has all requisite power and authority to execute and deliver the same and to bind IDA Developer hereunder.

(c) Binding Obligation and Enforcement. Assuming execution of this Agreement by StadCo and Metro, this Agreement constitutes legal, valid, and binding obligations of the IDA Developer, enforceable against IDA Developer in accordance with its terms.

(d) Contracts; No Conflict. The execution, delivery, and performance of this Agreement by IDA Developer does not and will not result in or cause a termination, modification, cancellation, violation or breach of, conflict with, constitute a default under, result in the acceleration of, create in any party the right to accelerate, require any consent, approval, waiver, amendment, authorization, notice or filing under any agreement, contract, understanding, instrument, mortgage, lease, sublease, license, sublicense, franchise, permit, indenture, agreement, mortgage for borrowed money, instrument of indebtedness, security instrument, indenture, document or other obligation to which IDA Developer is a party or by which IDA Developer or any of its properties or assets are bound.

(e) Governing Documents. The execution, delivery, and performance of this Agreement by IDA Developer does not and will not result in or cause a violation or breach of, or conflict with, any provision of its articles of organization, operating agreement or other governing documents.

(f) Law. The execution, delivery, and performance of this Agreement by IDA Developer does not and will not result in or cause a violation or breach of, or conflict with, Applicable Laws applicable to IDA Developer or any of its respective properties or assets which will have a material adverse effect on IDA Developer's ability to perform and satisfy its obligations and duties hereunder. All actions and determinations required to be taken or made by IDA Developer prior to the Effective Date have been taken or made.

(g) Absence of Litigation. There is no action, suit, proceeding, claim, arbitration or investigation pending or, to the knowledge of IDA Developer, threatened by any Person, against IDA Developer or its assets or properties that questions the validity of this Agreement or the transactions contemplated herein or which, individually or collectively, if unfavorably determined would have a material adverse effect on the assets, conditions, affairs or prospects of IDA Developer, financially or otherwise, including the ability of IDA Developer to perform and satisfy its obligations and duties hereunder

Section 4.3 Representations and Warranties of StadCo. StadCo represents and warrants to the IDA Developer and Metro, as of the Effective Date (unless otherwise expressly provided herein), as follows:

(a) Organization. StadCo is a Delaware limited liability company duly organized, validly existing, and in good standing under the laws of the State of Delaware and duly authorized to do business in the State of Tennessee. StadCo possesses full and adequate power and authority to own, operate, and lease its properties, and to carry on and conduct its business as it is currently being conducted.

(b) Authorization. StadCo has the full right, power, and authority to execute and deliver this Agreement and to perform and satisfy its obligations and duties hereunder. The execution, delivery, and performance of this Agreement by StadCo have been duly and fully

authorized and approved by all necessary and appropriate action, and a true, complete, and certified copy of the authorizing resolutions has been delivered to the IDA Developer and Metro. This Agreement has been duly executed and delivered by StadCo. The individual executing and delivering this Agreement on behalf of StadCo has all requisite power and authority to execute and deliver the same and to bind StadCo hereunder.

(c) Binding Obligation and Enforcement. Assuming execution of this Agreement by the IDA Developer and Metro, this Agreement constitutes legal, valid, and binding obligations of StadCo, enforceable against it in accordance with its terms.

(d) Contracts; No Conflict. The execution, delivery, and performance of this Agreement by StadCo does not and will not result in or cause a termination, modification, cancellation, violation or breach of, conflict with, constitute a default under, result in the acceleration of, create in any party the right to accelerate, require any consent, approval, waiver, amendment, authorization, notice or filing under any agreement, contract, understanding, instrument, mortgage, lease, sublease, license, sublicense, franchise, permit, indenture, agreement, mortgage for borrowed money, instrument of indebtedness, security instrument, indenture, document or other obligation to which StadCo is a party or by which StadCo or any of its properties or assets are bound.

(e) Governing Documents. The execution, delivery, and performance of this Agreement by StadCo does not and will not result in or cause a violation or breach of, or conflict with, any provision of its articles of organization, operating agreement or other governing documents, or the NFL Rules and Regulations.

(f) Law. The execution, delivery, and performance of this Agreement by StadCo does not and will not result in or cause a violation or breach of, or conflict with, any Applicable Laws applicable to StadCo or any of its properties or assets which will have a material adverse effect on the ability of StadCo to perform and satisfy its obligations and duties hereunder. All actions and determinations required to be taken or made by StadCo prior to the Effective Date have been taken or made.

(g) Absence of Litigation. There is no action, suit, proceeding, claim, arbitration or investigation pending or, to the knowledge of StadCo, threatened by any Person, against StadCo or its assets or properties that questions the validity of this Agreement or the transactions contemplated herein or which, individually or collectively, if unfavorably determined would have a material adverse effect on the assets, conditions, affairs or prospects of StadCo, financially or otherwise, including the ability of StadCo to perform and satisfy its obligations and duties hereunder.

## **ARTICLE 5 GENERAL CAMPUS COORDINATION PROVISIONS; CAMPUS COORDINATION COMMITTEE**

Section 5.1 General Considerations. IDA Developer, Metro and StadCo have a mutual interest in facilitating coordination with respect to (i) the exchange of information regarding the

operation and use of the Stadium, the Second Street Plaza, the Initial Development Area and the rest of the Campus and (ii) the activation of the Second Street Plaza by the Parties.

Section 5.2 Formation of Campus Coordination Committee. IDA Developer, Metro and StadCo agree to appoint a Campus Coordination Committee (the “CCC”) to, among other things, consult with and advise the IDA Developer, Metro and StadCo in connection with logistical and coordination issues with respect to (i) the exchange of information regarding the management and operation of activities at the Stadium and (ii) the events at the Second Street Plaza. The CCC shall consist of three (3) members, one (1) of which will be selected by IDA Developer, one (1) of which will be selected by Metro and one (1) of which will be selected by StadCo. The IDA Developer, Metro and StadCo may each remove and replace its member(s) and select alternates at its discretion and at any time so long as the ratio of representation among IDA Developer, Metro and StadCo remains 1:1:1. The Parties agree that no person shall be selected to serve as a member of the CCC if the participation of such person would cause the meetings of the CCC to be subject to the Open Meetings Act, Tennessee Code Annotated Section 8-44-101, *et seq.*

Section 5.3 Purpose. The purpose of the CCC is (i) to keep IDA Developer, Metro and StadCo reasonably informed on Stadium operational activities and reasonably coordinated on issues affecting the Second Street Plaza, the Initial Development Area and other portions of the Campus, including, without limitation, scheduling, planning, communications, staffing, traffic control, parking, and access with respect to activities at the Stadium and corresponding events at the Second Street Plaza and the allocation of resources among events and other activities at different areas within the Campus; and (ii) to provide a meaningful forum in which the Parties may voice their opinions and recommendations regarding the same (“Campus Coordination”). The CCC will develop initial operational principles and guidelines applicable to Campus Coordination and its decision-making process and outcomes no later than the date that is six (6) months prior to the first Stadium Event, which initial principles and guidelines may be modified by the CCC from time to time during the term of this Agreement.

Section 5.4 Campus Coordination Meetings and Procedures. The CCC shall hold Campus Coordination meetings on a date and at a time and place mutually agreeable to the members of the CCC. At the first meeting of the CCC, the CCC shall establish mutually acceptable regular meeting dates which shall initially be no less than once per month, notice requirements for meetings, procedures for the conduct of meetings (which may include the conduct of meetings by telephone and/or virtual platform such as Zoom and quorum requirements), procedures for voting and making recommendations to the IDA Developer, Metro and StadCo and such other procedures as the CCC members deem appropriate and as otherwise necessary to implement the requirements of this Section 5.4 (“CCC Procedures”). One Person, who may but shall not be required to be a member of the CCC, shall be designated by the CCC to maintain minutes of all meetings.

(a) The CCC shall elect a Chair from one of its members to preside over its meetings. CCC meetings may include, in addition to duly selected members of the CCC, any other Persons invited by the IDA Developer, Metro or StadCo to facilitate Campus Coordination, subject to advance written notice pursuant to CCC Procedures. However, at the request of a singular CCC member in writing, a meeting shall be attended only by the three CCC members. Any other Persons invited to attend the CCC meetings by the IDA Developer, Metro or StadCo who are not

members of the CCC will not have any voting rights on matters presented to the CCC for approval, but will have full rights to otherwise participate in the meetings.

(b) All information discussed or generated at a CCC Meeting shall be held by the CCC members and the Parties (and the CCC members and the Parties shall cause any other persons who attend the CCC meetings to hold such information) as confidential information to the maximum extent allowable under Tennessee law, unless all CCC members agree in writing that specified information may be disclosed to third parties. Information discussed or generated at a CCC Meeting may be disseminated among the employees of a Party (by such Party's CCC member) as reasonably necessary to implement coordination objectives contemplated by this Agreement. However, a singular CCC member may designate in writing, pursuant CCC Procedures, that specified information be disclosed only to officers and executives of a Party. Notwithstanding anything herein, Metro shall have the right to disclose to the Metro Council and any other governmental authorities and/or representatives thereof any information discussed or generated at a CCC Meeting including, without limitation, any disclosure to keep elected officials reasonably informed about the CCC's activities.

(c) CCC meeting agendas will include, but not be limited to, the discussion and formalization of the framework for logistical considerations applicable to Campus Coordination for activities at the Stadium and StadCo Plaza Events and other Plaza Events within the ensuing seven (7) day, four (4) week and twelve (12) month time periods and as otherwise suggested by StadCo, Metro or the IDA Developer. The following topics are a suggested list of subjects to guide the CCC regarding meeting agendas but are not meant to be prescriptive in nature (in addition, the listing of any such topics below does not suggest that this Agreement (or any other applicable Project Document) does not govern such matters to the extent addressed herein (or in such other applicable Project Document) or that the CCC has any authority to modify or waive any of the terms of this Agreement (or of any such other Project Documents), and Section 12.22 shall apply in all instances:

(i) General overview of all events on the Second Street Plaza ("Plaza Events") and/or events in the Stadium that would affect the Initial Development Area, including without limitation, areas of use, times of use, types of use and expectations of event organizers and promoters.

(ii) Review of Operating Plans and Traffic Plans for all Stadium Events, Special Stadium Events and Plaza Events.

(iii) Creation and implementation of a plan for Campus Coordination external messaging by both StadCo and the IDA Developer for all StadCo Plaza Events and other Plaza Events, which may include topics such as methods for communicating with external stakeholders, such as IDA Ground Tenants, their respective subtenants, operators, licensees, concessionaires, contractors and service associates, other Initial Development Area occupants and visitors, the general public and neighboring businesses.

(iv) Pedestrian flow management and coordination within the Initial Development Area for all Stadium Events, Special Stadium Events and Plaza Events, which may include topics such as- safety and security of all common areas on the Initial Development Area

to include plazas, crosswalks, walkways, vertical connections (elevators and escalators), crowd control equipment, temporary directional signs, staffing and hours of operation, it being understood and agreed that, among other considerations, the pedestrian bridge/walkway shall never be closed or restricted by the IDA Developer or any IDA Ground Tenant without Metro's prior written consent, such consent not to be unreasonably withheld, conditioned or delayed, except for temporary closures or restrictions in the event of an emergency, for which no consent by Metro shall be required.

(v) Stadium Events, Special Stadium Events and Plaza Events programming coordination, which may include topics such as establishing the appropriate Stadium Event Operational Period (if applicable), the recommendation of locations (including locations for temporary and event-related directional signage), set up times for activities outside the Stadium, programming operations for activities outside the Stadium and the times and processes for dismantling of any temporary displays, exhibits, sponsorship activation, and free speech areas outside of the Stadium. Stadium Events, Special Stadium Events and Plaza Events programming coordination may also include security and public safety coordination (medical and traffic management), grounds/landscaping maintenance personnel, electricians and general maintenance staff, third party contractors (as needed), equipment setup and dismantling responsibilities, custodial responsibilities and logistics of police escorts for cash handling, each as applicable to Campus Coordination.

(d) As required to facilitate coordination, the CCC members may choose to document specific event related Campus Coordination decisions will be documented by a master checklist of staffing and equipment, provided that such checklist is not intended to constitute a legally binding agreement and shall not be deemed or construed as a waiver or amendment of any terms of this Agreement (or of any other applicable Project Documents).

(e) To the extent a plan for a Plaza Event or series of Plaza Events is repetitive or substantially similar for such Plaza Events, a CCC member will only provide such plan at the beginning of each yearly CCC session (as defined in the CCC Procedures), subject to material changes or other material impacts on the Initial Development Area and/or any other areas of the Campus.

(f) All Campus Coordination meetings will have minutes and recommendations, if any, with respect to proposed Operating Plans and/or Traffic Plans, as applicable, that were discussed at the meeting. Subject to the confidentiality provisions of Section 5.4(b), such minutes will be recorded by a staff member and will be distributed to members of the CCC and designated management staff (and to any Plaza User to the extent relating to a Plaza Event to be held by such Plaza User) for review and comment promptly following conclusion of the meeting; provided, however, in no event shall such meeting minutes or any recommendations therein be deemed or construed as an amendment or waiver of any of the terms of this Agreement (or of any other applicable Project Documents).

(g) The CCC shall not be permitted to disapprove the proposed Operating Plan and/or Traffic Plan for any reason other than the plan does not comply with the requirements of this Agreement or any other applicable Project Documents, any Applicable Laws, or the then applicable operational principles and guidelines applicable to Campus Coordination.

Section 5.5 Authority. All recommendations of the CCC to the IDA Developer, Metro and StadCo shall be non-binding unless such recommendations are memorialized in writing and executed by one member of the CCC appointed by IDA Developer, one member appointed by Metro and one member appointed by StadCo, subject to modifications approved by the CCC in order to comply with NFL Rules and Regulations (which approval will not be unreasonably withheld) and modifications approved by the CCC in order to comply with the requirements to host a Special Stadium Event (which approval will not be unreasonably withheld). Notwithstanding any recommendations memorialized in writing and executed by members of the CCC, Section 12.22 shall apply in all instances.

Section 5.6 Dispute Resolution. It is the Parties' intent that any dispute between the Parties arising under this Agreement or with respect to Campus Coordination generally shall be resolved pursuant to Article 11, subject, in all instances, to Section 12.22.

## **ARTICLE 6 EVENT PLANNING AND COORDINATION**

Section 6.1 General Considerations. The Parties have agreed upon the Booking Priority System, as set forth below, to govern certain of the priorities and procedures for booking Plaza Events. As soon as practical, but in no event later than six (6) months after the Effective Date, StadCo will propose to the CCC a comprehensive booking policy for Plaza Events, including event policies/procedures, the appropriate advance notice period for booking events and such other activities customarily found in Comparable Plaza Facilities (the "Plaza Booking Policy"); provided that the Plaza Booking Policy will incorporate the Booking Priority System set forth below. Prior to any use of the Second Street Plaza by any Person for a Plaza Event other than with respect to a StadCo Plaza Event or a Metro Plaza Event, StadCo shall require such Person to enter into a Plaza Event License Agreement in a form acceptable to StadCo (each a "Plaza Event License Agreement") which such Plaza Event License Agreement shall require the Plaza User to save, indemnify and hold Metro harmless from any and all liability (including, but not limited to, liability for reasonable attorney's fees, fines, and penalties) and any injury, loss, expense or damage to person or property arising out of any cause associated with such use of the Second Street Plaza, all in a form approved by Metro and may require such Plaza User to obtain reasonable insurance coverage pursuant to a schedule of insurance coverages for Plaza Users, as reasonably (and mutually) determined by StadCo and Metro for Plaza Users from time to time.

Section 6.2 Master Calendar. StadCo will maintain, or cause to be maintained, an online master calendar (the "Master Calendar") of (i) all upcoming StadCo Plaza Events for which a StadCo Plaza Event Notice has been delivered and (ii) all upcoming Plaza Events booked in accordance with the Plaza Booking Policy. The Master Calendar shall be accessible by the duly appointed members of the CCC and will identify the dates of all such Plaza Events and other relevant information relating thereto (e.g., contact information for the applicable event organizers and promoters, the expected starting and ending times and areas of use, etc.).

Section 6.3 Designation of Plaza Events. Plaza Events shall be designated in accordance with the following procedure:



(a) Booking Priority System. The booking priority system for Plaza Events will be as follows (the “Booking Priority System”):

(i) StadCo Plaza\_Events will have a first priority and superior right to use the Second Street Plaza (without the necessity of executing a Plaza Event License Agreement with respect thereto), and in no event shall any Plaza Events be booked at any time that would conflict with use of the Second Street Plaza in connection with a StadCo Plaza\_Event.

(ii) Metro Plaza Events will have the second highest priority for booking of the Second Street Plaza. Metro shall provide StadCo with at least seventy (70) days’ prior written notice of its intent to book the Second Street Plaza for a Metro Plaza Event with respect to which no conflict with a StadCo Plaza Event exists. If Metro complies with the foregoing notice requirements, StadCo may not reschedule a Metro Plaza Event for a subsequently scheduled StadCo Plaza Event except for a StadCo Plaza Event pertaining to a Stadium Event or a Special Stadium Event and provided that StadCo gives Metro at least thirty (30) days’ advance written notice of same (unless thirty (30) days’ advance written notice is not practicable under the circumstances, in which case StadCo will give Metro as much advance written notice as reasonably practicable).

(iii) All other Plaza Events will have the third highest priority for booking of the Second Street Plaza. The user of the Plaza for such Plaza Event shall provide StadCo with at least sixty (60) days’ prior written notice of its intent to book the Second Street Plaza for a Plaza Event with respect to which no conflict with a StadCo Plaza Event or Metro Plaza Event exists. If such user complies with the foregoing notice requirements, StadCo may not reschedule such Plaza Event booking for a subsequently scheduled StadCo Plaza Event unless StadCo provides such user with at least thirty (30) days’ advance written notice that it has a material need for use of the Plaza for a StadCo Plaza Event.

(b) Booking of StadCo Plaza Events.

(i) Within thirty (30) days after the Team’s then upcoming NFL Season schedule is set and made public by the NFL, StadCo shall deliver a StadCo Plaza Event Notice to the CCC regarding all Team Games scheduled for such NFL Season as of such date with the dates and expected starting and ending time and the expected areas of use of the Second Street Plaza (if less than all) for each such Team Game (it being understood that such Team Games are subject to change based on then-current NFL Rules and Regulations). StadCo shall provide to the CCC additional StadCo Plaza Event Notices for rescheduled Team Games not less than two (2) days before each such Team Game. StadCo Plaza Events other than Team Games shall be designated in one or more additional StadCo Plaza Event Notices delivered by StadCo to the CCC as soon as reasonably practicable after each such StadCo Plaza Event is scheduled (or rescheduled) with the dates and expected starting and ending time and expected areas of use of the Second Street Plaza for each such StadCo Plaza Event. StadCo shall provide to the CCC additional notices for any other events StadCo intends to schedule for the Second Street Plaza as soon as reasonably practicable after each such StadCo Plaza Event is scheduled (or rescheduled) with the dates

and expected starting and ending time and expected areas of use of the Second Street Plaza for each such StadCo Plaza Events.

(ii) On or before each June 1 of each calendar year, StadCo shall submit to Metro a list of no fewer than forty (40) dates, which shall be reasonably disbursed both (A) throughout the calendar year and (B) throughout the days of the week (“Metro-Available Dates”) on which the Second Street Plaza would be available for a Metro Plaza Event to be scheduled pursuant to this Section 6.3(b) and Section 6.3(c) during the period beginning on the immediately succeeding August 10 and ending on August 9 of the following calendar year. Until such Metro-Available Dates are released as set forth below, StadCo shall not commit the Second Street Plaza for any StadCo Plaza Event that does not pertain to a Stadium Event or a Special Stadium Event without first obtaining Metro’s prior written consent. Any Metro-Available Date on which a Metro Plaza Event has not been scheduled pursuant to Section 6.3(c) at least seventy (70) days prior to such Metro-Available Date shall be released to StadCo for scheduling without further notice or action.

(c) Booking for Metro Plaza Events. If Metro wishes to book the Second Street Plaza for a Metro Plaza Event on a date and time that does not conflict with a StadCo Plaza Event, Metro must submit requests for the applicable date and space holds and all booking status changes to the designated StadCo staff via approved forms or approved electronic methods. Confirmation of the booking request for a Metro Plaza Event will be transmitted back to Metro via approved forms and will reflect status of the requests (e.g., tentatively scheduled, finally confirmed, cancellations, etc.). All such booking requests for a Metro Plaza Event will take priority over all other Plaza Events except a StadCo Plaza Event. Metro shall be entitled to successfully schedule not more than twenty (20) Metro Plaza Events in any calendar year (in addition to, for the avoidance of doubt, any use of the Second Street Plaza in conjunction with any Special Stadium Event). Any events requested by Metro to be scheduled in excess of such twenty (20) events and such Special Stadium Events shall instead be treated as a Separate Event, as described in subsection (d) below.

(d) Booking for Other Plaza Events. If Metro or the IDA Developer (or any other Persons, subject to the approval of Metro, the IDA Developer and StadCo) wish to book the Second Street Plaza for a Plaza Event on a date and time that does not conflict with a StadCo Plaza Event or a Metro Plaza Event (a “Separate Event”), StadCo, Metro, the IDA Developer or any other Person must submit a request for the applicable date and space holds and all booking status changes to the designated StadCo staff via approved forms or approved electronic methods. Confirmation of all Separate Event booking request submissions will be transmitted by StadCo back to the Party or Person submitting the request via approved forms and will reflect status of the requests (e.g., tentatively scheduled, finally confirmed, cancellations, etc.). All such Separate Event booking requests will be prioritized on a first-come first-serve basis.

(e) Booking Conflicts. In the event of any booking conflicts, (i) any Separate Event will always be rescheduled in order to accommodate a StadCo Plaza Event or a Metro Plaza Event; (ii) subject to 6.3(a)(ii), any Metro Plaza Event will be rescheduled in order to accommodate a StadCo Plaza Event; (iii) subject to Section 6.3(f), a scheduled Separate Event will have priority over a subsequent request for a conflicting Separate Event booking.

(f) In addition, StadCo and the CCC shall mutually agree in advance on the dates for all planned renovations and scheduled maintenance requiring a closure of the Second Street Plaza, absent exigent circumstances required for Stadium needs, health and safety requirements or otherwise required within certain timeframes as dictated by NFL Rules and Regulations,. provided, in all such cases, StadCo shall use commercially reasonable efforts to minimize closure of the Second Street Plaza and any interference with Plaza Events. Dates for all such planned renovations and scheduled maintenance shall be placed on the Master Calendar.

Section 6.4 Plaza Event User Fees; Plaza Event Operating Costs. Any Plaza User shall be responsible for providing traffic and crowd control, security, janitorial services, trash collection and disposal, event set up and tear down and all other event-related services, at its sole cost and expense, with respect to the use and operation of the Second Street Plaza during any Plaza Event scheduled by such Plaza User, including any cost to repair any damage (excluding ordinary wear and tear) to the Second Street Plaza during the Plaza User's use of the Second Street Plaza. StadCo shall not charge a user fee for the use of the Second Street Plaza that exceeds StadCo's incremental costs for the operation and maintenance of the Second Street Plaza during a Plaza Event, and in no event shall StadCo be permitted to charge Metro a user fee with respect to a Metro Plaza Event.

Section 6.5 Plaza Event Operating Plan.

(a) Submission of Operating Plan. At least thirty (30) days prior to the commencement of any Plaza Event (except for Plaza Events booked within said thirty (30) day period with respect to which such information shall be submitted upon booking and except for StadCo Plaza Events to the extent they are substantially similar to prior StadCo Plaza Events), the Plaza User shall provide to the CCC with proposed plans for its activities on the Second Street Plaza ("Operating Plan"). The Parties also acknowledge that NFL Rules and Regulations may require modifications to Operating Plans after submission. The Plaza User shall consider the following information for inclusion in any Operating Plan, as may be reasonably necessary to facilitate coordination of activities and to avoid negative impacts on the Initial Development Area:

(i) A site plan showing locations of all exhibits, aisles and other Temporary Facilities within the Second Street Plaza;

(ii) Set-up information including tents, staging and similar requirements;

(iii) A plan indicating the design, nature and proposed location of all Temporary Facilities in the Second Street Plaza;

(iv) The name and address of, as applicable, of the exhibition service contractor, security contractor, and other Event Contractors to be utilized by the Plaza User; and

(v) The Traffic Plan submitted in accordance with Section 8.2 and other plans for providing traffic control, security, janitorial service, trash removal, clean up, tear down and other necessary services before, during and after the Event by the Plaza User.

(b) CCC Review of Operating Plan. The CCC shall review the Plaza User's Operating Plan at its next regularly scheduled or special called meeting for general conformance to this Agreement, any applicable Project Documents and any applicable Plaza Booking Policies then in effect. The Plaza User shall provide such additional planning information that the CCC may reasonably request for that review. The CCC may request that the Plaza User make reasonable changes to its Operating Plan to attain the safe and orderly operation of the Second Street Plaza in accordance with all Applicable Laws and substantial compliance, in all material respects, with this Agreement, any applicable Project Documents and any applicable Plaza Booking Policies then in effect, and any applicable NFL Rules and Regulations. If the CCC makes such request, the Plaza User who is conducting a Plaza Event will work with the CCC in good faith to resolve any objection to the Operating Plan, or update thereto, raised by the CCC. Once an Operating Plan is approved, the Plaza User may not make material changes in the approved Operating Plan without the CCC's consent, and the Plaza User shall conduct its operation of the applicable Plaza Event in substantial conformity with the Operating Plan reasonably approved by the CCC.

Section 6.6 Special Stadium Events. Any use of the Stadium for Special Stadium Events is governed by the Stadium Lease. The Parties agree to work together and with such other Persons as may be appropriate under the circumstances (e.g., the Nashville Convention & Visitors Corp., or any third-party event host entity (e.g., a local organizing committee)), in good faith, to determine rights, obligations and other parameters relative to the Campus with respect to Special Stadium Events, which may include an agreement that is comparable to Section 7.6(c), providing for protections of the sponsors or promoters of such Special Stadium Events from Ambush Marketing.

## **ARTICLE 7 CAMPUS USE AND OPERATIONS**

### Section 7.1 Second Street Plaza.

(a) The Parties acknowledge and agree that (i) StadCo is responsible for designing and constructing the Second Street Plaza at StadCo's sole cost and expense pursuant to the terms of the Stadium Development Agreement; and (ii) StadCo or its Affiliates shall (or shall cause the stadium manager or any other Person to) operate and maintain, at StadCo's sole cost and expense, the Second Street Plaza in a first class condition reasonably comparable to Comparable Plaza Facilities. Upon the completion of the Second Street Plaza, StadCo shall make the Second Street Plaza available for StadCo, Metro, the IDA Developer or any other Person authorized pursuant to Section 6.3(d) to conduct a Plaza Event, in each case subject to and in accordance with the terms of this Agreement, any applicable Project Documents and any Plaza Booking Policy then in effect.

(b) Except as expressly provided in this Agreement or any other applicable Project Documents, no fence, barrier or other structure obstructing pedestrian access over and across the Second Street Plaza to and from the Initial Development Area (except as required for the initial construction of improvements to the Second Street Plaza) shall be placed, kept, permitted or maintained upon the Second Street Plaza Site, without the prior written consent of the IDA Developer and StadCo. Notwithstanding the foregoing, temporary fencing or physical barriers may be utilized from time to time by a Plaza User to provide for crowd control and public

safety in connection with Plaza Events; provided, however, except as provided in this Agreement or any other applicable Project Documents (i) in no event shall any such temporary fencing or physical barriers be utilized in such a manner as to materially obstruct the visibility of or from or access to or from the improvements on IDA Parcel C to the Plaza or the Stadium, (ii) reasonable alternative access to and from the Initial Development Area shall be provided and (iii) all such temporary fencing or physical barriers shall be removed as soon as reasonably practicable following any applicable Plaza Event. Notwithstanding the foregoing, the prohibitions on fencing, barriers or other structures and temporary fencing or physical barriers contained in this Section 7.1(b) shall be subject and subordinate to NFL Rules and Regulations requiring temporary security fencing or barriers for Stadium Events, provided that (i) for Team Events, no opaque fencing shall be permitted; (ii) for Special Stadium Events that are subject to NFL Rules and Regulations, StadCo shall use commercially reasonable efforts to ensure that no opaque fencing will be utilized to obstruct the visibility of or from the improvements on IDA Parcel C to the Plaza or the Stadium; and (iii) reasonable alternative access to and from the Initial Development Area shall be provided for all Stadium Events.

(c) No events at the Second Street Plaza will be conducted in such a manner that would reasonably be expected to result in the loss of reasonable access to any of the buildings developed by IDA Developer within the Initial Development Area.

Section 7.2 Data Rights. Subject to compliance with Applicable Laws, StadCo shall have the exclusive right to exercise all StadCo's Data Rights with respect to, at, on or within all or any portion of the Stadium and the Second Street Plaza during Stadium Events (including, without limitation, during Special Stadium Events) and the related Stadium Operational Periods (except to the extent another Plaza User is using the Plaza during such period in accordance with the terms and conditions of this Agreement). Subject to compliance with Applicable Laws, any other Plaza User shall have the exclusive right to exercise all Plaza User's Data Rights with respect to, at, on or within all or any portion of the Second Street Plaza during a Plaza Event conducted by the Plaza User. Subject to compliance with Applicable Laws, the IDA Developer shall have the exclusive right to exercise all IDA Developer's Data Rights with respect to, at, on or within all or any portion of the Initial Development Area at all times. StadCo agrees to use commercially reasonable efforts not to intentionally over-broadcast its WIFI network serving the Stadium and the Second Street Plaza during Stadium Events so as to interfere with IDA Developer's Data Rights, and IDA Developer agrees to use commercially reasonable efforts -not to intentionally over-broadcast its WIFI network serving the Initial Development Area during Stadium Events so as to interfere with StadCo's Data Rights. Notwithstanding the foregoing, Plaza Users or their vendors shall have the exclusive right to exercise all Plaza User's Data Rights under their own point-of-sale systems.

Section 7.3 Commercial Rights. StadCo shall have the sole and exclusive right to exercise all StadCo's Advertising Rights, StadCo's Concession Rights and StadCo's Hospitality Rights at, on or within any portion of the Second Street Plaza with respect to Stadium Events during Stadium Event Operational Periods and those portions of temporary Advertising solely exploited during such Stadium Events within the Second Street Plaza, including, without limitation, the sole and exclusive right to operate, control and sell, and to retain all revenue from the foregoing. Subject to the terms and conditions of this Agreement (including, without limitation, Section 7.6 below), any other Plaza User shall have the exclusive right exercise all Plaza User's Advertising Rights, Plaza User's Concession Rights and Plaza User's Hospitality Rights at, on or within any portion of

the Second Street Plaza during a Plaza Event conducted by the Plaza User and those portions of temporary Advertising solely exploited during such Plaza Events within the Second Street Plaza, including, the sole and exclusive right to operate, control and sell, and to retain all revenue from the foregoing. Subject to the terms and conditions of this Agreement (including, without limitation, Section 7.6 below), the IDA Developer shall have the sole and exclusive right to exercise the IDA Developer's Advertising Rights, the IDA Developer's Concession Rights and the IDA Developer's Hospitality Rights at all times, including but not limited to during any Stadium Event Operational Period and during any Plaza Event. StadCo's temporary signage, concessions stands and video board shall not be located within the Second Street Plaza in a manner that materially obstruct the visibility of or from or access to or from the improvements on IDA Parcel B or IDA Parcel C to the Plaza or the Stadium.

Section 7.4 Digital Experiences and Assets. StadCo shall have the sole and exclusive right to control and monetize and grant to any other Person the right to control and monetize metaverse opportunities and other similar digital experiences now existing or hereafter developed at the Stadium and the Second Street Plaza or that relate to the Stadium or the Team, and to receive, retain and control all data related thereto. IDA Developer shall have the sole and exclusive right to control and monetize metaverse opportunities and other similar digital experiences now existing or hereafter developed at the at the Initial Development Area (excluding (i) any parking facility, if any, owned by Metro within the Initial Development Area or (ii) that relate to the Team, the Stadium or any Stadium Event). For the avoidance of doubt, if any commercial activities by IDA Developer are restricted or prohibited by this Agreement within the Second Street Plaza or the Initial Development Area, such commercial activities by IDA Developer shall be restricted or prohibited to a corresponding extent in any digital environment (as such environment may now exist or be hereafter developed).

Section 7.5 Integration of Technology. While the IDA Developer may pursue an independent technology solution if, after meeting in good faith, it determines that a joint approach is not practicable or in its best interest, IDA Developer shall use commercially reasonable efforts to integrate StadCo's technology partners in the course of the design, development and operations of IDA Parcel B and IDA Parcel C (excluding any parking facility, if any, owned by Metro on either IDA Parcel B or IDA Parcel C), to achieve coordinated mobile technology, which efforts may include participating in meetings with StadCo's technology partners and including such partners in requests for proposals and other similar opportunities to provide products and services for use throughout such areas to enhance the experience of being in such areas and endeavoring to achieve revenue and cost synergies.

Section 7.6 Advertising Limitations.

(a) Neither Metro, nor the IDA Developer, nor any IDA Ground Tenant shall market or sell, or permit to be marketed or sold, any IDA Advertising that (i) is disparaging toward any Premier Stadium Sponsor or (ii) advertises or promotes any competitive product or service within the categories of exclusivity granted by StadCo in connection with StadCo's Premier Stadium Sponsorships. In addition, neither Metro, nor the IDA Developer, nor any IDA Ground Tenant shall lease or sublease space to a tenant on IDA Parcel B, IDA Parcel C or IDA Parcel D for use by an automotive dealer or manufacturing company other than Nissan for the sale, lease, display or promotion of new or used vehicles so long as Nissan remains the Stadium Naming

Rights Sponsor (it being understood that if Nissan is no longer the Stadium Naming Rights Sponsor, the IDA Developer will work with StadCo in good faith to provide commensurate protection to a subsequent Stadium Naming Rights Sponsor, recognizing at a minimum that in the event the IDA Developer has previously leased space to a tenant on IDA Parcel B, IDA Parcel C or IDA Parcel D for a use that is in a category or categories for which each such subsequent Stadium Naming Rights Sponsor would have exclusivity (a “Preexisting Lease”), the Preexisting Lease shall be permitted for the term of the Preexisting Lease, including any renewal terms included in the Preexisting Lease). Notwithstanding anything to the contrary in this Agreement, neither Metro, nor the IDA Developer, nor any IDA Ground Tenant shall market or sell, or permit to be marketed or sold, any IDA Advertising that (i) is immediately facing or otherwise prominently visible from the Stadium Site or the Second Street Plaza, and (ii) that (A) is disparaging toward any Secondary Stadium Sponsor, or (B) advertises or promotes any competitive product or service within the categories of exclusivity granted by StadCo in connection with any Secondary Stadium Sponsorships.

(b) With respect to StadCo’s Premier Stadium Sponsorships and Secondary Stadium Sponsorships, StadCo will keep IDA Developer reasonably informed of (i) the category or categories of exclusivity that have been agreed upon by StadCo and any Premier Stadium Sponsor or Secondary Stadium Sponsor, and (ii) the identity of all Premier Stadium Sponsors and Secondary Stadium Sponsors, in each case by providing to IDA Developer, no less frequently than annually, a list of all such Premier Stadium Sponsorships and Secondary Stadium Sponsorships, which list shall include the names of the Premier Stadium Sponsors and Secondary Stadium Sponsors, the category or categories for which each such Premier Stadium Sponsor or Secondary Stadium Sponsor has exclusivity, and the date of termination of each such Premier Stadium Sponsorship or Secondary Stadium Sponsorship. In the event the identity of a Premier Stadium Sponsor or Secondary Stadium Sponsor changes after the IDA Developer has entered into a contract for any IDA Advertising that would otherwise be prohibited by Section 7.6(a) (a “Preexisting Contract”), the Preexisting Contract shall be permitted for the term of the Preexisting Contract, including any renewal terms included in the Preexisting Contract. In the event of the foregoing, the IDA Developer shall provide StadCo prompt written notice of (i) the Person party to the Preexisting Contract, (ii) the category or categories of exclusivity that conflict with the Premier Stadium Sponsorship or Secondary Stadium Sponsorship and (iii) the date of termination of the Preexisting Contract. IDA Developer agrees not to amend any Preexisting Contract to extend the initial terms or add any additional renewal terms following the receipt of the notification from StadCo of the change in the identity of a Premier Stadium Sponsor or Secondary Stadium Sponsor that conflicted with the Preexisting Contract.

(c) Metro, the IDA Developer and the IDA Ground Tenant, as applicable, shall use commercially reasonable efforts without the necessity to resort to litigation and without diminishing StadCo’s rights in law and equity, to protect the rights granted to StadCo under this Section 7.6, from intentional and obvious Ambush Marketing within the Initial Development Area, including without limitation, reasonably cooperating with StadCo to develop and implement a protection strategy to combat any such Ambush Marketing within the Initial Development Area. Without limiting the foregoing, the IDA Developer will reasonably cooperate with StadCo in the event StadCo determines to commence litigation to prevent or otherwise address Ambush Marketing in the Initial Development Area, provided such cooperation shall not require the IDA Developer to join or participate in any litigation. The Parties agree from time to

time to discuss in good faith additional actions to be taken to protect StadCo from Ambush Marketing within the Initial Development Area. IDA Developer will use commercially reasonable efforts to notify StadCo promptly in writing of IDA Developer becoming aware of any instances of Ambush Marketing located on the Initial Development Area.

(d) Notwithstanding anything to the contrary set forth in this Section 7.6, neither the IDA Developer nor any IDA Ground Tenant shall be responsible for any violation of any of the obligations of the IDA Developer contained in this Section 7.6 as the result of the actions of a tenant or invitee of the IDA Developer or any IDA Ground Tenant in any residential building or a customer or invitee in any hotel located within the Initial Development Area; provided, however, the IDA Developer shall use good faith efforts without the necessity to resort to litigation to implement appropriate policies and cause its tenants to implement appropriate policies to prevent any violations of this Section 7.6.

Section 7.7 Second Street Plaza Naming Rights. StadCo shall have the sole and exclusive right to sell to any Person (such Person, the “Plaza Naming Rights Partner”) and to retain all revenue from the sale of naming rights to the Second Street Plaza (the “Plaza Naming Rights”), provided that StadCo’s exercise of such Plaza Naming Rights shall be subject to the prior written approval of (i) the IDA Developer and Metro if the proposed exercise of the Plaza Naming Rights (A) violates any Applicable Law, (B) would reasonably cause embarrassment or disparagement the IDA Developer, its Affiliates or their tenants, or Metro (such as names containing slang, barbarisms, racial epithets, obscenities or profanity or names relating to any sexually-oriented business or enterprise or containing any overt political reference), or (C) contains the name of a state, city, or geographic designation that might be misleading or suggest that the Second Street Plaza is not located in Nashville, Tennessee, or (ii) the IDA Developer if the proposed exercise of the Plaza Naming Rights involves a direct competitor of any residential developer or hotel flag located on IDA Parcel C or IDA Parcel D or a direct brand name competitor of any retailer located on IDA Parcel C or IDA Parcel D whose premises faces the Second Street Plaza. The Parties acknowledge and agree that in connection with the foregoing, StadCo shall have the sole and exclusive right to grant category exclusivity to the Plaza Naming Rights Partner and grant the Plaza Naming Rights Partner the right to include permanent signage and other Advertising inventory within the Second Street Plaza (such rights, the “Plaza Naming Rights Partner Exclusive Rights”), and subject to any limitations imposed in connection with the hosting of any Special Stadium Events, StadCo and the Plaza Naming Rights Partner shall have no obligation to remove or obstruct the Plaza Naming Rights Partner Exclusive Rights during any Plaza User’s Plaza Event, and the Plaza Naming Rights Partner Exclusive Rights may remain visible and activated 365 days per year, unless otherwise directed by StadCo.

Section 7.8 Campus Sponsors. The IDA Developer, Metro and StadCo agree to negotiate in good faith with respect to the solicitation and formal engagement of any Person as a naming or similar sponsor of the Campus, excluding (for avoidance of doubt) the Stadium, the Second Street Plaza and the Initial Development Area (such Person, a “Campus Sponsor”) to collectively maximize revenue for the IDA Developer, Metro and StadCo with respect to such Advertising; provided, the decision to grant any rights to a Campus Sponsor shall be at the sole and absolute discretion of each Party, and any Campus Sponsor shall be subject to terms and conditions of this Agreement unless otherwise agreed by the Parties.



Section 7.9 Sports Betting and Casinos. Without StadCo’s prior written approval (such approval to be granted at StadCo’s sole discretion), neither the IDA Developer nor Metro nor any of their respective Affiliates shall grant the right to or otherwise authorize any Person to conduct, sell or lease any opportunities with respect to sports betting and Casinos throughout the Initial Development Area, including, without limitation, the right to provide wagering on real world sports competitions within the Initial Development Area, provided, however the foregoing shall not prohibit gambling or games of chance unrelated to real world sports competition operated by the Tennessee Lottery or an event benefitting a non-profit organization that is permitted by other Governmental Authorities or legal online gambling by Persons using their own devices.

Section 7.10 Construction Management Agreement. IDA Developer and StadCo agree to enter into a Construction Management Agreement (the “Construction Management Agreement”) within six (6) months of the Effective Date in order to address the construction development and coordination of the Stadium and the improvements to the Initial Development Area. The Construction Management Agreement shall address access to the Stadium Site and the Initial Development Area, site management of the Stadium Site and the Initial Development Area, scheduling and integration of construction activities, safety compliance and site security, laydown areas, materials storage, crane swing clearances and other similar issues.

Section 7.11 Parcel B Easement Area. The provisions of this Section 7.11 shall apply only following Substantial Completion of the Stadium and the full execution of an IDA Ground Lease for IDA Parcel B.

(a) Except as expressly provided in this Agreement or any other applicable Project Documents, no fence, barrier or other structure obstructing pedestrian access over and across the Parcel B Easement Area to and from IDA Parcel B shall be placed, kept, permitted or maintained upon the Parcel B Easement Area, without the prior written consent of the IDA Developer. Notwithstanding the foregoing, temporary fencing or physical barriers may be utilized from time to time by StadCo to provide for crowd control and public safety in connection with Stadium Events; provided, however, except as provided in this Agreement or any other applicable Project Documents (i) in no event shall any such temporary fencing or physical barriers be utilized in such a manner as to materially obstruct the visibility of or from or access to or from the improvements on IDA Parcel B to the Stadium, (ii) reasonable alternative access to and from IDA Parcel B to the Stadium shall be provided and (iii) all such temporary fencing or physical barriers shall be removed as soon as reasonably practicable following any applicable Stadium Event. Notwithstanding the foregoing, the prohibitions on fencing, barriers or other structures and temporary fencing or physical barriers contained in this Section 7.11(a) shall be subject and subordinate to NFL Rules and Regulations requiring temporary security fencing or barriers for Stadium Events, provided that (i) for Team Events, no opaque fencing shall be permitted; (ii) for Special Stadium Events that are subject to NFL Rules and Regulations, StadCo shall use commercially reasonable efforts to ensure that no opaque fencing will be utilized to obstruct the visibility of or from the improvements on IDA Parcel B to the Stadium; and (iii) reasonable alternative access to and from IDA Parcel B shall be provided for all Stadium Events.

(b) To the extent StadCo has or obtains the sole and exclusive right to sell to any Person (such Person, the “Parcel B Easement Area Naming Rights Partner”), and to retain all revenue from the sale of, naming rights specific to the Parcel B Easement Area (the “Parcel B

Easement Area Naming Rights”), any exercise by StadCo of such Parcel B Easement Area Naming Rights shall be subject to the prior written approval of (i) the IDA Developer and Metro if the proposed exercise of the Parcel B Easement Area Naming Rights (A) violates any Applicable Law, (B) would reasonably cause embarrassment or disparagement to the IDA Developer, its Affiliates or their tenants, or Metro (such as names containing slang, barbarisms, racial epithets, obscenities or profanity or names relating to any sexually-oriented business or enterprise or containing any overt political reference), or (C) contains the name of a state, city, or geographic designation that might be misleading or suggest that the Parcel B Easement Area is not located in Nashville, Tennessee, or (ii) the IDA Developer if the proposed exercise of the Parcel B Easement Area Naming Rights involves a direct competitor of any residential developer or hotel flag located on IDA Parcel B or a direct brand name competitor of any retailer located on IDA Parcel B whose premises faces the Parcel B Easement Area.

## **ARTICLE 8 CAMPUS ACCESS**

Section 8.1 Access Management. The Parties acknowledge that the Stadium Events, Special Stadium Events and Plaza Events conducted at the Stadium and Second Street Plaza will result in significant vehicular and pedestrian traffic on the streets, sidewalks and other pedestrian ways on the Initial Development Area. The proper management of vehicular and pedestrian traffic is critically important to the efficient functioning of not only the Stadium and the Second Street Plaza, but of the IDA Developer’s surrounding development within the Initial Development Area and other portions of the Campus operated by Metro or its successors and assigns. Therefore, the Parties agree that the vehicular and pedestrian traffic shall be managed in accordance with the provisions of this Article 8 provided, however, Section 12.22 shall apply and control in all instances.

Section 8.2 Traffic Plan. A proposed vehicular and pedestrian traffic management plan for one or more Stadium Events, Special Stadium Events and Plaza Events (each a “Traffic Plan”) shall be prepared by the Party conducting the Stadium Events, Metro Plaza Events or Plaza Events (or by any other Plaza User who is conducting a Plaza Event) and shall be provided to the CCC at least thirty (30) days prior to the proposed Stadium Events, Special Stadium Events or Plaza Events. For avoidance of doubt, a single plan applicable to multiple Stadium Events, Special Stadium Events and Plaza Events may be submitted and, if necessary, updated, at least thirty (30) days prior to the applicable event, to take into account special facts and considerations related to such event. Within ten (10) days of receiving a Traffic Plan or an update thereto, the CCC shall advise the Party conducting the Stadium Events, Special Stadium Events or Plaza Events (or any other Plaza User who is conducting a Plaza Event) of any reasonable objections to the Traffic Plan, or an update thereto, raised by any member of the CCC. If no member of the CCC raises a timely objection, the Traffic Plan, or an update thereto, shall be deemed approved. If the CCC raises a timely objection, the Party conducting the Stadium Events, Special Stadium Events or Plaza Events (or any other Plaza User who is conducting a Plaza Event) will work with the CCC in good faith to resolve any objection to the Traffic Plan, or an update thereto, raised by the CCC.

Section 8.3 Temporary Street Closure. The Traffic Plan will be designed and operated in such a manner as to minimize, to the extent reasonably practical, (i) the duration of any obstruction of any vehicular or pedestrian ingress or egress points for the Stadium, the Second Street Plaza or for any building located on the Initial Development Area; and (ii) limitations on the general public's ability to access East Nashville from downtown, and vice versa. Any temporary street closure proposed in the Traffic Plan will to the extent reasonably practical, provide exceptions to permit vehicular and pedestrian access to the tenants, occupants and the invitees of any buildings or private outdoor space with vehicular and/or pedestrian access points on the street proposed for the temporary closure.

## **ARTICLE 9 DEFAULTS AND REMEDIES**

Section 9.1 Events of Default and Remedies. The occurrence of any one or more of the following events shall constitute an "Event of Default":

(a) A Party's failure to pay any amounts due hereunder or within thirty (30) days of a written request for the payment thereof from the Party to whom the sum is due; or

(b) if (i) a Party fails to observe or perform any material covenant, condition, agreement or obligation hereunder other than the Party's obligations referenced in subsection (a) above (so long as such failure to observe or perform is not caused by the acts or omissions of any of the other Parties which constitutes a breach of this Agreement), and (ii) the defaulting Party fails to cure, correct or remedy such default within thirty (30) days after the receipt of written notice thereof from any of the other Parties, describing it with reasonable specificity, unless such failure cannot with due diligence be cured within a period of thirty (30) days, in which case such failure shall not be deemed to continue if the defaulting Party proceeds promptly and with due diligence to cure the failure and uses commercially reasonable efforts to complete the curing thereof; or

(c) if any representation or warranty of a Party set forth in this Agreement shall prove to be incorrect in any material respect as of the time when the same shall have been made, and the Party fails to cure, correct or remedy such failure to be true within thirty (30) days after the receipt of written notice thereof from any of the other Parties, unless such failure cannot with due diligence be cured within a period of thirty (30) days, in which case such failure shall not be deemed to continue if the defaulting Party proceeds promptly and with due diligence to cure the failure and uses commercially reasonable efforts to complete the curing thereof; or

(d) except as otherwise provided by Applicable Laws, if any Party shall be judicially declared bankrupt or insolvent according to law or if any assignment shall be made of the property of the Party for the benefit of creditors, or if a receiver, guardian, conservator, trustee in involuntary bankruptcy or other similar officer shall be appointed to take charge of all or any substantial part of the Party's property by a court of competent jurisdiction, or if a petition shall be filed for the reorganization of the Party under any provisions of law now or hereafter enacted, and such proceeding is not dismissed within ninety (90) days after it is begun (in each case, other than at the request of or on behalf of any of the other Parties), or if the Party shall file a petition

for such reorganization, or for arrangements under any provisions of such laws providing a plan for a debtor to settle, satisfy or extend the time for the payment of debts.

Section 9.2 Remedies. Subject to the cure rights set forth in Section 9.1(a) or Section 9.1(b), the non-defaulting Party or Parties may take any or all of the following actions on account of an Event of Default pursuant to Section 9.1:

- (a) Obtain specific performance of the obligation of the defaulting Party.
- (b) Exercise self-help to attempt to remedy or mitigate the effect of any breach of his Agreement by the defaulting Party and recover all actual and reasonable costs and expenses, including without limitation attorney's fees, incurred by the non-defaulting Party or Parties in connection therewith.
- (c) Any non-defaulting Party may exercise such other remedies as may be available at law or in equity, EXCEPT AS LIMITED BY Section 11.2(h).

## **ARTICLE 10 STANDARDS FOR APPROVALS**

Section 10.1 Review and Approval Rights. The provisions of this Article 10 shall be applicable with respect to all instances in which it is provided under this Agreement that StadCo or the StadCo Representative, Metro or the Metro Representative or the IDA Developer or the IDA Developer Representative exercises Review and Approval Rights; *provided, however*, that if the provisions of this Article 10 specifying time periods for exercise of Review and Approval Rights shall conflict with other express provisions of this Agreement providing for time periods for exercise of designated Review and Approval Rights, then the provisions of such other provisions of this Agreement shall control. As used herein, the term "Review and Approval Rights" shall include, without limiting the generality of that term, all instances in which one Party (the "Submitting Party") is permitted or required to submit to the other Party or to the representative of that other Party any document, notice or determination of the Submitting Party and with respect to which the other Party or its representative (the "Reviewing Party") has a right or duty hereunder to review, comment, confirm, consent, Approve, disapprove, dispute or challenge the submission or determination of the Submitting Party.

Section 10.2 Standard for Review.

(a) General. Unless this Agreement specifically provides that a Party's Review and Approval Rights may be exercised in the sole discretion of the Reviewing Party, then in connection with exercising its Review and Approval Rights under any provision of this Agreement, and whether or not specifically provided in any such provision, the Reviewing Party covenants and agrees to act in good faith, with due diligence, and in a fair and commercially reasonable manner in its capacity as Reviewing Party with regard to each and all of its Review and Approval Rights and to not unreasonably withhold, condition or delay its Approval of, consent to or confirmation of any submission or determination. The Reviewing Party shall review the matter submitted in writing and shall promptly (but in any event within fifteen (15) days after such receipt) give Notice to the Submitting Party of the Reviewing Party's comments resulting from such review and, if the matter is one that requires Approval or confirmation pursuant to the terms of this

Agreement, such Approval, confirmation, disapproval or failure to confirm, setting forth in detail the Reviewing Party's reasons for any disapproval or failure to confirm. Any failure to respond within the foregoing fifteen (15) day period shall not be deemed to be an approval or confirmation of the matter submitted unless within five (5) Business Days thereafter the submitting party resubmits the matter in writing with a prominent, all capital letters disclaimer that states – THIS IS A RESUBMISSION OF A PREVIOUSLY SUBMITTED MATTER TO WHICH TIMELY RESPONSE WAS NOT MADE AND FAILURE TO RESPOND TO THIS RESUBMISSION WITHIN A FURTHER TEN (10) DAYS SHALL BE DEEMED TO BE AN APPROVAL. A failure to respond within the foregoing ten (10) day period shall then be deemed to be an approval or confirmation of the matter submitted.

(b) Specific Matters. Unless otherwise provided herein, the Reviewing Party's right to disapprove or not confirm any matter submitted to it for Approval or confirmation and to which this Section 10.2 applies shall be limited to the elements thereof: (a) that do not conform in all material respects to Approvals or confirmations previously given with respect to the same matter; and (b) that propose or depict matters that are or the result of which would be a violation of or inconsistent with the provisions of this Agreement or Applicable Law.

Section 10.3 Resubmissions. If the Reviewing Party disapproves of or fails to confirm a matter to which this Section 10.3 applies within the applicable time period, the Submitting Party shall have the right, within twenty (20) days after the Submitting Party receives Notice of such disapproval or failure to confirm, to re-submit the disapproved or not confirmed matter to the Reviewing Party, altered to satisfy the Reviewing Party's basis for disapproval or failure to confirm (all subsequent re-submissions with respect to such matter must be made within ten (10) days of the date the Submitting Party receives Notice of disapproval or failure to confirm of the prior re-submission). The applicable Submitting Party shall use reasonable efforts to cause any such re-submission to expressly state that it is a re-submission, to identify the disapproved or not confirmed portion of the original submission and any prior resubmissions, and to not be included with an original submission unless the matter previously disapproved is expressly identified thereon. Any resubmission made pursuant to this Section 10.3 shall be subject to Review and Approval Rights of the Reviewing Party in accordance with the procedures described in this Article 10 for an original submission (except that the Review and Approval Rights shall be limited to the portion previously disapproved or not confirmed), until such matter shall be Approved by the Reviewing Party.

Section 10.4 Duties, Obligations, and Responsibilities Not Affected. Approval or confirmation by the Reviewing Party of or to a matter submitted to it by the Submitting Party shall neither, unless specifically otherwise provided (a) relieve the Submitting Party of its duties, obligations or responsibilities under this Agreement with respect to the matter so submitted nor (b) shift the duties, obligations or responsibilities of the Submitting Party with respect to the submitted matter to the Reviewing Party.

## **ARTICLE 11 DISPUTE RESOLUTION PROCEDURES**

Section 11.1 Intent. It is intended by the Parties to resolve any dispute, controversy or claim between or among the Parties arises under this Agreement or any right, duty or obligation

arising therefrom or the relationship of the Parties thereunder (a “Dispute or Controversy”), including a Dispute or Controversy relating to the (a) effectiveness, validity, interpretation, implementation, termination, cancellation or enforcement of this Agreement or (b) the granting or denial of any Approval under this Agreement, through reasonable business-like negotiations without resort to litigation, if possible. If a Dispute or Controversy should arise under this Agreement, the Parties shall attempt to resolve the dispute in accordance with this Article 11 (the “Dispute Resolution Procedures”) prior to or during the pendency of any litigation. No Party shall cease or delay performance of its obligations under this Agreement during the existence of any Dispute or Controversy, and all Parties shall pay to any other Party all amounts owing and not subject to dispute or offset.

Section 11.2 Resolution Procedure. The Parties shall attempt to resolve any Dispute or Controversy in accordance with the following procedures:

(a) Special Meeting. Any Party may make its final proposal in writing and in reasonable detail to the other Party or Parties involved in any Dispute or Controversy with respect to the resolution of the Dispute or Controversy (the “Dispute Resolution Proposal”), and if the recipient Party or Parties do not agree to the Dispute Resolution Proposal within seven (7) Business days following its receipt thereof (the “First Resolution Deadline”), then the Parties shall refer the Dispute or Controversy to their respective Chief Executive Officers, Presidents or equivalents (the “Senior Executives”), and the Parties shall cause the Senior Executives to meet (the “Senior Executives Meeting”) at least once (in person or by telephone conference call or ZOOM meeting) within seven (7) Business Days after the First Resolution Deadline and negotiate in good faith to resolve the Dispute or Controversy.

(b) Mandatory Mediation. If the Dispute or Controversy has not been resolved within seven (7) Business Days after the special meeting has occurred (the “Second Resolution Deadline”), any Party thereto may, at its option, initiate a mediation proceeding which shall be attended by all Parties to the Dispute or Controversy and which, unless all Parties to such proposed mediation proceeding agree otherwise, shall be conducted by an independent mediator from Judicial Arbitration and Mediation Services in accordance with its procedures. The costs of the mediation shall be shared equally by all Parties to such mediation. No Party may file any litigation or any other legal proceedings until after the Second Resolution Deadline, but the mediation proceedings may be conducted before or during the pendency of any litigation or other legal proceedings.

(c) Settlement. If, as a result of the mediation, a voluntary settlement is reached and the Parties agree that such settlement shall be reduced to writing, the mediator shall hereby be deemed appointed and constituted an arbitrator for the sole purpose of signing the mediation agreement. Such agreement shall have the same force and effect as an arbitration award and judgment may be entered upon it in accordance with applicable law in any court having jurisdiction thereof.

(d) Evidentiary Rules. The proceedings under this Section shall be subject to the applicable evidence rules and code of the State of Tennessee. Further, the Parties agree that evidence of anything said or presented, or of any admission made during or in the course of the special meeting or mediation shall not be admissible in evidence or subject to discovery, and

disclosure of such evidence shall not be compelled, in any arbitration, court action or proceeding. All communication, negotiations, or settlement discussions by and between participants or mediators in the mediation shall remain confidential. This provision shall not limit the discoverability or admissibility of evidence if all Persons who conducted or otherwise participated in the mediation consent to its disclosure. The Parties expressly agree and further agree that the presentation of evidence from any expert or consultant shall not waive any attorney-client or other privilege or exclusionary rule a party may later seek to assert in another proceeding.

(e) Limitations. The Dispute Resolution Procedures shall not in any way affect any statutes of limitation relating to Dispute or Controversy or other matter or question arising out of or relating to this Agreement or the breach thereof.

(f) Litigation Costs. In any litigation between the Parties, the Party who prevails on the merits of the litigation shall be entitled to recover, in addition to all other relief obtained, reasonable attorneys' fees and expenses of that litigation provided, however, in no event shall any Party be entitled to recover such reasonable attorneys' fees and expenses from Metro and Metro shall have no obligation or liability with respect thereto, and in no event shall Metro be entitled to recover such reasonable attorneys' fees and expenses from another Party and such Party shall have no obligation or liability to Metro with respect thereto.

(g) Venue. No litigation by any Party may be brought against any other Party except in the Chancery or Circuit Court of Davidson County, State of Tennessee.

(h) Limitation of Liability. No Party shall in any event be liable for any consequential, punitive or exemplary damages to another Party.

## **ARTICLE 12 MISCELLANEOUS PROVISIONS**

Section 12.1 Notices. All notices, demands, submissions, requests, consents, approvals and other instruments required or permitted to be given pursuant to the terms hereof, shall be in writing and shall be deemed to have been properly given if (i) delivered by hand, (ii) or sent by registered or certified United States mail, postage prepaid, return receipt requested, (iii) by nationally recognized overnight mail or courier service (with signed confirmation of receipt) or (iv) by e-mail to the following addresses, respectively:

To IDA Developer      TFC Nashville Development LLC  
   c/o The Fallon Company LLC  
   1222 Demonbreun Street  
   Nashville, TN 37203  
   Attn: Ben Farrer  
   Email: bfarrer@falloncompany.com

and                                      TFC Nashville Development LLC  
   c/o The Fallon Company LLC  
   One Marina Park Drive  
   Boston, MA 02210

Attn: Brian Awe  
Email: bawe@falloncompany.com

with a copy to: Bradley, Arant, Boult Cummings, LLP  
One 22 One  
1221 Broadway, Suite 2400  
Nashville Tennessee 37203  
Attn: J. Thomas Trent  
Email: ttrent@bradley.com

To Metro: Nashville City Hall, Suite 100  
1 Public Square  
Nashville, Tennessee 37201  
Attn.: Mayor

with a copy to: Metropolitan Department of Law  
1 Public Square, Suite 108  
Nashville, Tennessee 37201  
Attn.: Department of Law  
Email: tom.cross @nashville.gov

Greenberg Traurig, LLP  
1000 Louisiana Street, Suite 6700  
Houston, Texas 77002  
Attn: Denis C. Braham  
Email: denis.braham@gtlaw.com

To StadCo: Tennessee Stadium, LLC  
St. Thomas Sports Park  
460 Great Circle Road  
Nashville Tennessee 37228  
Attn: President/CEO  
Email: bnihill@titans.nfl.com

with a copy to: Tennessee Stadium, LLC  
St. Thomas Sports Park  
460 Great Circle Road  
Nashville Tennessee 37228  
Attn: Chief Operating Officer  
Email: dwerly@titans.nfl.com

or to such other addresses as may from time to time be specified in writing by any party hereto. Any notices or other communications under this Agreement must be in writing, and shall be deemed duly given or made at the time and on the date when received by e-mail transmittal of pdf files or similar electronic means or when personally delivered as shown on a receipt therefor (which shall include delivery by a nationally recognized overnight delivery service) to the address



for each Party set forth above or when delivery is refused. Any Party, by written notice to the other in the manner herein provided, may designate an address different from that set forth below. Notwithstanding the foregoing to the contrary, any notice received by e-mail or other electronic means after 6:00 pm CT shall be deemed given or made on the next Business Day. Any notice to be given by any party hereto may be given by the counsel for such Party.

Section 12.2 Amendment. This Agreement may be amended, modified or supplemented but only in a writing signed by each of the Parties. A signed writing by Metro to implement any amendment, modification or supplementation required by Applicable Law to be approved by the Metro Council must be approved pursuant to a resolution (and not an ordinance) by the Metro Council.

Section 12.3 Waivers. The failure of a party hereto at any time or times to require performance of any provision hereof shall in no manner affect its right at a later time to enforce the same. No waiver by a Party of any condition or of any breach of any term, covenant, representation or warranty contained in this Agreement shall be effective unless in writing, and no waiver in any one or more instances shall be deemed to be a further or continuing waiver of any such condition or breach in other instances or a waiver of any other condition or breach of any other term, covenant, representation or warranty.

Section 12.4 Counterparts. This Agreement may be executed and delivered in counterparts, each of which shall be deemed an original, but all of which together shall constitute one and the same instrument. A facsimile or other electronic signature (including a .pdf) of any party shall be considered to have the same binding effect as an original signature.

Section 12.5 Knowledge. The term “knowledge” or words of similar import shall mean the knowledge after reasonable inquiry of the officers or key employees of any Party with respect to the matter in question as to the date with respect to which such representation or warranty is made.

Section 12.6 Drafting. The Parties acknowledge and confirm that each of their respective attorneys have participated jointly in the review and revision of this Agreement and that it has not been written solely by counsel for one Party. The Parties further agree that the language used in this Agreement is the language chosen by the Parties to express their mutual intent and that no rule of strict construction is to be applied against any Party.

Section 12.7 No Third-Party Beneficiaries. This Agreement is solely for the benefit of the Parties hereto and, to the extent provided herein, their respective Affiliates, board members, agents, successors, and permitted assigns, and no provision of this Agreement shall be deemed to confer upon other Persons any remedy, claim, liability, reimbursement, cause of action or other right.

Section 12.8 Entire Understanding. This Agreement, together with the other IDA Project Documents, sets forth the entire agreement and understanding of the Parties hereto with respect to the transactions contemplated hereby and supersede any and all prior agreements, arrangements, and understandings among the Parties relating to the subject matter hereof, and any and all such

prior agreements, arrangements, and understandings shall not be used or relied upon in any manner as parol evidence or otherwise as an aid to interpreting this Agreement.

Section 12.9 Governing Law, Venue; Waiver of Jury.

(a) Governing Law. This Agreement and the transactions contemplated hereby, and all disputes between the Parties under or related to the Agreement or the facts and circumstances leading to its execution, whether in contract, tort or otherwise, shall be governed by and construed in accordance with the laws of the State of Tennessee, applicable to contracts executed in and to be performed entirely within the State of Tennessee, without regard to the conflicts of laws principles thereof.

(b) Venue. Subject to the terms of Article 11, each of the Parties hereby irrevocably and unconditionally submits, for itself and its Property, to the exclusive jurisdiction of the Chancery Court of Davidson County, Tennessee or federal court of the United States of America and any appellate court from any thereof, in any proceeding arising out of or relating to this Agreement or the agreements delivered in connection herewith or the transactions contemplated hereby or thereby or for recognition or enforcement of any judgment relating thereto, and each of the Parties hereby irrevocably and unconditionally (i) agrees not to commence any such proceeding except in such courts, (ii) agrees that any claim in respect of any such proceeding may be heard and determined in the Chancery Court of Davidson County, Tennessee or in such federal court, (iii) waives, to the fullest extent it may legally and effectively do so, any objection which it may now or hereafter have to the laying of venue of any such proceeding in any such court, and (iv) waives, to the fullest extent permitted by law, the defense of an inconvenient forum to the maintenance of such action or proceeding in any such court. Each of the Parties agrees that a final judgment in any such proceeding shall be conclusive and may be enforced in other jurisdictions by suit on the judgment or in any other manner provided by law.

(c) Waiver of Jury Trial. EACH PARTY ACKNOWLEDGES AND AGREES THAT ANY CONTROVERSY WHICH MAY ARISE UNDER THIS AGREEMENT IS LIKELY TO INVOLVE COMPLICATED AND DIFFICULT ISSUES, AND THEREFORE IT HEREBY IRREVOCABLY AND UNCONDITIONALLY WAIVES ANY RIGHT IT MAY HAVE TO A TRIAL BY JURY IN RESPECT OF ANY LITIGATION DIRECTLY OR INDIRECTLY ARISING OUT OF OR RELATING TO THIS AGREEMENT AND ANY OF THE AGREEMENTS DELIVERED IN CONNECTION HEREWITH OR THE TRANSACTIONS CONTEMPLATED HEREBY OR THEREBY. EACH PARTY HERETO CERTIFIES AND ACKNOWLEDGES THAT (I) NO REPRESENTATIVE, AGENT OR ATTORNEY OF ANY OTHER PARTIES HAS REPRESENTED, EXPRESSLY OR OTHERWISE, THAT SUCH OTHER PARTIES WOULD NOT, IN THE EVENT OF LITIGATION, SEEK TO ENFORCE EITHER OF SUCH WAIVERS, (II) IT UNDERSTANDS AND HAS CONSIDERED THE IMPLICATIONS OF SUCH WAIVERS, (III) IT MAKES SUCH WAIVERS VOLUNTARILY, AND (IV) IT HAS BEEN INDUCED TO ENTER INTO THIS AGREEMENT BY, AMONG OTHER THINGS, THE MUTUAL WAIVERS AND CERTIFICATIONS IN THIS SECTION 11.10. THIS SECTION SHALL SURVIVE ANY TERMINATION OF THIS AGREEMENT.

Section 12.10 Time is of the Essence. The times for performance provided in this Agreement are essential due to the obligations and expenditures of the Parties. If a time is not specified, performance shall be required promptly and with due regard to the conditions of performance of other Parties in reliance thereon. All provisions in this Agreement that specify or provide a method to compute a number of days for the performance, delivery, completion or observance by a Party of any action, covenant, agreement, obligation or notice hereunder shall mean and refer to calendar days, unless otherwise expressly provided. However, if the date specified or computed under this Agreement for the performance, delivery, completion or observance of a covenant, agreement, obligation or notice by either Party, or for the occurrence of any event provided for herein, is a Saturday, Sunday or Legal Holiday, then the date for such performance, delivery, completion, observance or occurrence shall automatically be extended to the next calendar day that is not a Saturday, Sunday or Legal Holiday.

Section 12.11 Severability. If any provision of this Agreement shall be held invalid, illegal or unenforceable, the validity, legality or enforceability of the other provisions hereof shall not be affected thereby, and there shall be deemed substituted for the provision at issue a valid, legal and enforceable provision as similar as possible to the provision at issue. This Section 12.11 shall not be construed or implemented in a manner that substantially deprives any Party of the overall benefit of its bargain under this Agreement.

Section 12.12 Relationship of the Parties. Metro, the IDA Developer and StadCo are independent parties and nothing contained in this Agreement shall be deemed to create a partnership, joint venture, agency or employer-employee relationship among them or to grant to any of them any right to assume or create any obligation on behalf of or in the name of the others of them.

Section 12.13 Further Assurances/Additional Documents and Approval. A Party, upon reasonable request of the other Party, shall execute and deliver, or cause to be executed and delivered, any additional documents and shall take such further actions as may be reasonably necessary or expedient in order to consummate the transactions provided for in, and to carry out the purpose and intent of, this Agreement and/or to comply with or satisfy the requirements of the Act.

Section 12.14 Recording. This Agreement shall not be recorded, but at the request of any Party, the Parties shall promptly execute, acknowledge, and deliver to each other a memorandum of this Agreement in a form reasonably agreed upon by the Parties (and a memorandum of modification of this Agreement in respect of any modification of this Agreement) sufficient for recording. Such memorandum shall not be deemed to change or otherwise affect any of the obligations or provisions of this Agreement and shall confirm that this Agreement runs with the Land under Section 12.17 hereof.

Section 12.15 Estoppel Certificate. Each of the Parties agrees that within ten (10) Business Days after receipt of a written request by any other Party, shall execute, acknowledge, and deliver to the requesting party a statement in writing certifying: (a) that this Agreement is unmodified and in full force and effect or, if there have been modifications, that the same are in full force and effect as modified and identifying the modifications; (b) that such Party is not (to the best of that Party's

knowledge) in default under any provisions of this Agreement or, if there has been a default, the nature of such default; and (c) such other factual matters as requested by the requesting Party.

Section 12.16 Limitation of Liability. Notwithstanding anything to the contrary contained in this Agreement, but without limitation of any Party's equitable rights and remedies, except as otherwise provided in any other instrument executed and delivered to any other Party in connection with this Agreement, no direct or indirect member, manager, partner, owner, shareholder, director, officer, employee, trustee, agent or representative in or of a Party or any of its Affiliates (each, other than a Party, a "Nonrecourse Party") shall have any personal liability in any manner or to any extent under this Agreement and no Party nor any Person claiming by, through or under such Party shall have any recourse to any assets of a Nonrecourse Party. The limitation of liability provided in this Section 12.16 is in addition to, and not in limitation of, any limitation on liability applicable to a Nonrecourse Party provided by law or by this Agreement or any other contract, agreement or instrument. No owner, member, officer, director, manager, employee, agent, appointee, representative or other individual acting in any capacity on behalf of either of the Parties or their Affiliates shall have any personal liability or obligations under, pursuant to, or with respect to this Agreement for any reason whatsoever.

Section 12.17 Runs with the Land. During the COUA Term, this Agreement, and Metro's, the IDA Developer's and StadCo's respective rights hereunder, each constitute an interest in the Second Street Plaza Land and Initial Development Area Land (excluding any parking facility, if any, owned by Metro within the Initial Development Area) (collectively, the "Land"), and Metro, the IDA Developer and StadCo intend that interest be non-revocable and assignable, in each case, in accordance with, but subject to the terms of this Agreement and any applicable Project Documents; and constitute an interest in real estate that runs with title to the Land, and inures to the benefit of and is binding upon Metro, the IDA Developer, StadCo and their respective permitted successors in title and permitted assigns, subject to the terms of this Agreement and any applicable Project Documents.

Section 12.18 Reserved.

Section 12.19 Prohibition Against Boycotting Israel. To the extent this Agreement constitutes a contract with to acquire or dispose of services, supplies, information technology, or construction for the purposes of Tennessee Code Annotated Section 12-4-119, neither StadCo, the IDA Developer nor any of their wholly owned subsidiaries, majority-owned subsidiaries, parent companies or affiliates, are currently engaged in nor will they engage in a boycott of Israel from the date hereof through the expiration or termination of this Agreement. For the purposes of Section 12-4-119, "boycott of Israel" shall mean engaging in refusals to deal, terminating business activities, or other commercial actions that are intended to limit commercial relations with Israel, or companies doing business in or with Israel or authorized by, licensed by, or organized under the laws of the State of Israel to do business, or persons or entities doing business in Israel, when such actions are taken (i) in compliance with, or adherence to, calls for a boycott of Israel, or (ii) in a manner that discriminates on the basis of nationality, national origin, religion, or other unreasonable basis, and is not based on a valid business reason.

Section 12.20 Public Records. The Parties agree that neither StadCo nor the IDA Developer is an office, department, or agency of Metro for purposes of Tennessee Code Annotated

Sections 10-7-403 and 10-7-701. Neither StadCo nor the IDA Developer is a custodian of records for Metro, nor are StadCo or the IDA Developer responsible for maintaining Metro's documents arising from or relating to this Agreement.

Section 12.21 Permitted Assignment by Metro. Metro may assign all of its rights and obligations under this Agreement to an authority or instrumentality (a "New Authority") which has been formed by Metro, so long as such New Authority holds title (whether by fee title, leasehold interest or assignment of rights) to the entire Initial Development Area, exclusive of public rights of way.

Section 12.22 Metro's Rights as Sovereign. Metro retains all its sovereign prerogatives, rights and regulatory authority (quasi-judicial or otherwise) as a consolidated city-county government under Applicable Laws with respect to the planning, design, construction, development and operation of the Campus, including the Initial Development Area. It is expressly understood that notwithstanding any provisions of this Agreement and Metro's status as a Party hereto, any Metro covenant or obligation that may be contained in this Agreement shall not bind Metro, the Metro Council to grant or leave in effect any Governmental Authorization that may be granted, withheld, or revoked by Metro in the exercise of its/their police power(s).

Section 12.23 Permitted Assignment by StadCo. StadCo shall have the right to assign its rights, privileges, duties and obligations hereunder in connection with a Permitted Assignment, as defined in the Stadium Lease, to the same Person that is the permitted transferee pursuant to such Permitted Assignment. Following such assignment, StadCo shall be released from any obligations hereunder that accrue following the date of such assignment.

Section 12.24 Permitted Assignment by IDA Developer. The IDA Developer shall have the right to assign its rights, privileges, duties and obligations hereunder that have not been previously assigned to any IDA Ground Tenant, to any IDA Ground Tenant or to the CAE, in each case subject to such IDA Ground Tenant or the CAE (i) ratifying its joinder agreement and (ii) expressly confirming in such ratification its assumption of the rights, privileges, duties and obligations so assigned and assumed. Following such assignment, the IDA Developer shall be released from any obligations hereunder that accrue following the date of such assignment.

[Remainder of Page Left Blank Intentionally]

IN WITNESS WHEREOF, this Agreement has been executed by the Parties as of the Effective Date.

TFC NASHVILLE DEVELOPMENT LLC, a  
Delaware Limited Liability Company

By: \_\_\_\_\_  
Brian Awe  
President

THE METROPOLITAN GOVERNMENT OF  
NASHVILLE AND DAVIDSON COUNTY

By: \_\_\_\_\_  
Metropolitan Mayor

ATTEST:

By: \_\_\_\_\_  
Metropolitan Clerk

APPROVED AS TO FORM AND LEGALITY:

\_\_\_\_\_  
Director of Law

TENNESSEE STADIUM, LLC, a Delaware  
limited liability company

By: \_\_\_\_\_  
Name: \_\_\_\_\_  
Title: \_\_\_\_\_

**EXHIBIT A  
TO  
SITE COORDINATION AGREEMENT**

**GLOSSARY OF DEFINED TERMS AND RULES OF USAGE**

“Act” shall mean the Sports Authorities Act of 1993, as amended, codified as Chapter 67, of Title 7 of the Tennessee Code Annotated.

“Actions or Proceedings” shall mean any lawsuit, proceeding, arbitration or other alternative dispute resolution process, Governmental Authority investigation, hearing, audit, appeal, administrative proceeding, or judicial proceeding.

“Advertising” means the sale of advertising, sponsorship, signage, displays, and other promotional activity, in each case whether in form now existing or developed in the future. Office, retail, restaurant or hotel tenant signage, wayfinding signage, directional signage and other non-revenue producing signage shall not constitute Advertising.

“Affiliate” shall mean, with respect to a specified Person, any other Person that, directly or indirectly, through one or more intermediaries, Controls, is Controlled by or is under common Control with the Person specified. For purposes of this definition, the terms “Controls,” “Controlled by” or “under common Control” shall mean the power to direct the management or policies of an entity or conduct the day-to-day business operations of such entity (directly or indirectly), whether through the ownership of voting securities, partnership or other ownership interests, by contract or otherwise (including being the general partner, officer or director of the entity in question); provided, however, that Control shall not be deemed absent solely because a non-managing member, partner or shareholder has the right to approve certain major decisions.

“Agreement” shall have the meaning set forth in the preamble of this Agreement.

“Ambush Marketing” means any attempt by another Person, without StadCo’s consent or the NFL’s consent, to associate itself or its products or services with the Team, the NFL, or any of the NFL’s Entities, or to directly or indirectly suggest that such product or service is endorsed by or otherwise associated with the Team, StadCo, the NFL of any of the NFL Entities. Ambush Marketing shall include, but not be limited to, the unauthorized use of TeamCo’s and StadCo’s intellectual property; the unauthorized use of free tickets for Stadium Events in consumer prize giveaways, contests, sweepstakes or other promotions; the creation of any Advertising that incorporates a theme or image that would lead a reasonable person to believe the non-sponsor advertiser is in some way associated with or has been endorsed by the Team, StadCo, the NFL, or any of the NFL’s Entities; and any other Advertising, marketing, or promotion that is undertaken by an unauthorized third party and gives the public the impression that the unauthorized third party: (i) has an official association, approval or sponsorship with the with the Team, StadCo, the NFL of any of the NFL Entities, or (ii) otherwise to imply a direct or indirect association, approval, or sponsorship with the Team, StadCo, the NFL of any of the NFL Entities as a means of promoting the unauthorized third party’s business, products, or services.

“Applicable Law(s)” or “applicable law(s)” or “Law(s)” shall mean any and all laws (including all statutory enactments and common law), ordinances, constitutions, regulations,

treaties, rules, codes, standards, permits, requirements, and orders that (a) have been adopted, enacted, implemented, promulgated, ordered, issued, entered or deemed applicable by or under the authority of any Governmental Authority or arbitrator having jurisdiction over a specified Person (or the properties or assets of such Person), and (b) are applicable to this Agreement or the performance of the obligations of the parties under this Agreement.

“Approval” or “approve” shall mean (a) with respect to any item or matter for which the approval of Metro is required under the terms of this Agreement, the specific approval of such item or matter by Metro pursuant to a written instrument executed by authorized official of Metro or the Metro Representative, as permitted pursuant to the terms of this Agreement, and delivered to StadCo and the IDA Developer, and shall not include any implied or imputed approval, but shall include any approval that is deemed approved pursuant to the terms of this Agreement, and no approval by the Metro or the Metro Representative pursuant to this Agreement shall be deemed to constitute or include any approval required in connection with any governmental functions of Metro; (b) with respect to any item or matter for which the approval of the IDA Developer is required under the terms of this Agreement, the specific approval of such item or matter by the IDA Developer or the IDA Developer Representative, as the case may be, pursuant to a written instrument executed by a duly authorized officer of the IDA Developer or the IDA Developer Representative, as permitted pursuant to the terms of this Agreement, and delivered to StadCo and Metro and shall not include any implied or imputed approval, but shall include any approval that is deemed approved pursuant to the terms of this Agreement; (c) with respect to any item or matter for which the approval of StadCo is required under the terms of this Agreement, the specific approval of such item or matter by StadCo or the StadCo Representative, as the case may be, pursuant to a written instrument executed by a duly authorized officer of StadCo or the StadCo Representative, as permitted pursuant to the terms of this Agreement, and delivered to the Metro and the IDA Developer and shall not include any implied or imputed approval, but shall include any approval that is deemed approved pursuant to the terms of this Agreement; and (d) with respect to any item or matter for which the approval of any other Person is required under the terms of this Agreement, the specific approval of such item or matter by such Person pursuant to a written instrument executed by a duly authorized representative of such Person and delivered to the IDA Developer, Metro or StadCo, as applicable, and shall not include any implied or imputed approval. In such use, all Approvals shall not be unreasonably withheld, conditioned or delayed, unless the terms of this Agreement specify otherwise.

“Authority” shall have the meaning set forth in the Recitals of this Agreement.

“Booking Priority System” shall have the meaning set forth in Section 6.3(a) of this Agreement.

“Business Day” shall mean a day of the year that is not a Saturday, Sunday, Legal Holiday or a day on which commercial banks are not required or authorized to close in Nashville, Tennessee.

“CAE” shall have the meaning set forth in Section 1.3(b) of this Agreement.

“Campus” shall have the meaning set forth in the Recitals of this Agreement and, for the avoidance of doubt, excludes the Stadium.



“Campus Coordination” shall have the meaning set forth in Section 5.3 of this Agreement

“Campus Sponsor” shall have the meaning set forth in Section 7.8 of this Agreement

“Casino” shall mean any building that provides gambling-based games typically found in casinos that consist of dealing, operating, carrying on, conducting, maintaining, or exposing for play any game played with cards, dice, equipment, or any mechanical or electromechanical device, such as poker, roulette, craps, twenty-one, black jack, baccarat, slot machines, keno or any other gambling-based game similar in form or content where money or credit is wagered.

“CCC” shall have the meaning set forth in Section 5.2 of this Agreement.

“CCC Procedures” shall have the meaning set forth in Section 5.4 of this Agreement.

“Common Areas” shall have the meaning set forth in Section 1.3(b) of this Agreement.

“Comparable Plaza Facilities” shall mean open-air plazas located in mixed-use developments anchored by multi-purpose sports and entertainment facilities existing as of the Effective Date.

“COUA Term” shall have the meaning set forth in Section 3.1 of this Agreement.

“Commissioner” shall mean the Commissioner of the NFL.

“Construction Management Agreement” shall have the meaning set forth in Section 7.10 of this Agreement.

“Cornerstone Sponsor” shall mean one of up to six (6) Persons total that from time to time has been granted rights to any or all of the assets comprising a Cornerstone Sponsorship.

“Cornerstone Sponsorship” shall mean one of up to six (6) sponsorships (other than a Stadium Naming Rights Sponsorship or a Secondary Stadium Sponsorship) which shall have category exclusivity for any one or more categories agreed upon by StadCo and the applicable Cornerstone Sponsor.

“Cumberland” means Cumberland Stadium, Inc., a Delaware corporation.

“Day(s)” or “day(s)” shall mean calendar days, including weekends and legal holidays, whether capitalized or not, unless otherwise specifically provided.

“Declaration” shall have the meaning set forth in the Recitals of this Agreement.

“Dispute or Controversy” shall have the meaning set forth in Section 11.1 of this Agreement.

“Dispute Resolution Procedures” shall have the meaning set forth in Section 11.1 of this Agreement.

“Dispute Resolution Proposal” shall have the meaning set forth in Section 11.2(a) of this Agreement.

“Effective Date” shall have the meaning set forth in the preamble of this Agreement.

“Event Contractors” shall mean each exhibition service contractor, and security, emergency medical services, audio/visual or other contractors providing goods or services to a Plaza User conducting an event in the Second Street Plaza.

“Existing Stadium” shall mean the existing Nissan Stadium located on the east bank of the Cumberland River that is the current home stadium for the Tennessee Titans.

“First Amended SCA” shall have the meaning set forth in the Recitals of this Agreement.

“First Resolution Deadline” shall have the meaning set forth in Section 11.2(a) of this Agreement.

“Governmental Authority” shall mean any federal, state, county, city, local or other government or political subdivision, court or any agency, authority, board, bureau, commission, department or instrumentality thereof.

“IDA Advertising” shall mean the sale of Off-Premise Advertising to be located in the Initial Development Area, whether in form now existing or developed in the future, by the IDA Developer, any IDA Ground Tenant, or any business located on any portion of the Initial Development Area. For the avoidance of doubt, ordinary course office, retail, restaurant or hotel tenant signage, wayfinding signage, directional signage and other non-revenue producing signage shall not constitute IDA Advertising so long as such signage is not independently sold as revenue producing inventory.

“IDA Concessions” means, collectively, all food and beverages, including all alcoholic beverages (subject to procurement of all necessary Government Approvals), and IDA Merchandise sold by the IDA Developer, any IDA Ground Tenant, or any business located within the Initial Development Area.

“IDA Developer” shall mean TFC Nashville Development LLC, a Delaware limited liability company.

“IDA Developer Representative(s)” shall have the meaning set forth in Section 2.3 of this Agreement.

“IDA Developer’s Advertising Rights” means the right to display, control, conduct, lease, permit, sell, publish and enter into agreements regarding the display of all IDA Advertising on any portion of the Initial Development Area.

“IDA Developer’s Concession Rights” means the right to market, sell, display, distribute and store IDA Concessions and to conduct catering and banquet sales and service, within the Initial Development Area.

“IDA Developer’s Data Rights” means the right to collect, use, sell, license, display, publish or otherwise use, names, contact information and other identifiable information with respect to, at, on or within all or any portion of the Initial Development Area.

“IDA Developer’s Hospitality Rights” means the right to market and sell hospitality assets within the Initial Development Area, including, without limitation, tickets, experiences, IDA Concessions and IDA Merchandise.

“IDA Development Agreement” shall have the meaning set forth in the Recitals of this Agreement.

“IDA Ground Lease” shall have the meaning set forth in the Recitals of this Agreement.

“IDA Ground Tenant” means, with respect to each IDA Ground Lease, the applicable tenant or tenants under such IDA Ground Lease, collectively or individually as the context suggests or requires.

“IDA Ground Tenant Assignee” shall have the meaning set forth in Section 1.3(a) of this Agreement.

“IDA Land” means the Initial Development Area.

“IDA Merchandise” means souvenirs, apparel, publications, retail goods, other merchandise and other non-edible items, goods, equipment (including mechanical, electrical or computerized amusement devices) and wares sold by the IDA Developer, any IDA Ground Tenant, or any business located within the Initial Development Area.

“IDA Parcel” shall have the meaning set forth in the Section 1.3(a) of this Agreement.

“IDA Parcel B” shall have the meaning set forth in the Recitals of this Agreement.

“IDA Parcel C” shall have the meaning set forth in the Recitals of this Agreement.

“IDA Parcel D” shall have the meaning set forth in the Recitals of this Agreement.

“IDA Project Documents” shall mean collectively, this Agreement, the IDA Development Agreement, the IDA Ground Leases and the Construction Management Agreement.

“Initial Development Area” shall have the meaning set forth in the Recitals of this Agreement. For the avoidance of doubt, the Initial Development Area shall not include the Second Street Plaza Site.

“Land” shall have the meaning set forth in Section 12.17 of this Agreement.

“Legal Holiday” shall mean any day, other than a Saturday or Sunday, on which the County’s administrative offices are closed for business.

“Master Calendar” shall have the meaning set forth in Section 6.2 of this Agreement.

“Metro” shall mean The Metropolitan Government of Nashville and Davidson County.

“Metro-Available Dates” shall have the meaning set forth in Section 6.3(b)(ii).

“Metro Council” shall mean the Metropolitan Council of Metro.

“Metro Plaza Event” shall mean any event at the Second Street Plaza scheduled (or requested to be scheduled) pursuant to Section 6.3(b)(ii) of this Agreement.

“Metropolitan Mayor” means the Mayor of The Metropolitan Government of Nashville and Davidson County.

“Metro Representative” shall have the meaning set forth in Section 2.1 of this Agreement.

“New Authority” shall have the meaning set forth in Section 12.21 of this Agreement.

“NFL” shall have the meaning set forth in the Recitals of this Agreement.

“NFL Entities” means any entity that is, directly or indirectly, jointly owned by all or substantially all of the NFL member clubs (including NFL Productions LLC, NFL Properties LLC, NFL Enterprises LLC, NFL International LLC, NFL Ventures, Inc., NFL Ventures, L.P. and any successor or future entity that is, directly or indirectly, in whole or in part, jointly owned and/or controlled by all or substantially all of the NFL member clubs or that owns assets that produce revenues that are required to be shared with other NFL member clubs under the NFL Constitution and their respective subsidiaries and other affiliates).

“NFL Management Council” shall mean the not-for-profit association formed by the member clubs of the NFL to act as the representative of such member clubs in the conduct of collective bargaining and other player relations activities of mutual interest to such member clubs.

“NFL Rules and Regulations” shall mean the Constitution and Bylaws of the NFL, including, without limitation, all resolutions, rules and policies adopted and/or promulgated thereunder, and the Articles of Association and Bylaws of the NFL Management Council, including any amendments to either such document and any interpretations of either such document issued from time to time by the Commissioner which are within the Commissioner’s jurisdiction; all operative NFL or NFL Management Council resolutions that are within the NFL’s or the NFL Management Council’s respective jurisdictions; any existing or future agreements entered into by the NFL or the NFL Management Council, including, without limitation, any television agreements or any collective bargaining or other labor agreements (including without limitation, any NFL player salary guarantees and pension fund agreements), and any agreements made in settlement of any litigation against the NFL, the NFL Management Council, or the NFL member clubs (including litigation against such clubs, or agreements made by such clubs, jointly or collectively); any agreements and arrangements to which such party is or after the date of this Lease may become subject or by which it or its assets are or may become bound with or in favor of the NFL and its affiliates; and such other rules or policies as the NFL, the NFL Management Council, or the Commissioner may issue from time to time that are within the issuing party’s jurisdiction, including, without limitation, all financial and other reporting requirements of the NFL

“Nonrecourse Party” shall have the meaning set forth in Section 12.16 of this Agreement.

“Notice” shall mean any Approval, consent, demand, designation, request, election or other notice that any Party gives to the other Party regarding this Agreement.

“Off-Premise Advertising” means Advertising that is used to advertise or inform by directing attention to a cause, event, campaign, business, profession, commodity, product, service, or entertainment that is conducted, sold, distributed, or offered elsewhere than upon the same premises as the Off-Premise Advertising, or that directs attention to any brand name or trade name product that may be only incidentally available on the same premises as the Off-Premise Advertising.

“Operating Plan” shall have the meaning set forth in Section 6.5(a) of this Agreement.

“Original SCA” shall have the meaning set forth in the Recitals of this Agreement.

“Parcel B Easement Area” shall have the meaning set forth in the Recitals of this Agreement.

“Parcel B Easement Area Naming Rights” shall have the meaning set forth in Section 7.7 of this Agreement.

“Parcel B Easement Area Naming Rights Partner” shall have the meaning set forth in Section 7.7 of this Agreement.

“Parking Agreement” shall mean that certain that certain Parking Facilities Development, Operations and Use Agreement dated on or about the date hereof by and between Metro and StadCo.

“Party” and “Parties” shall have the meaning set forth in the preamble of this Agreement.

“Person” or “Persons” shall mean any individual, corporation, partnership, joint venture, association, joint stock company, trust, limited liability company, unincorporated organization, Governmental Authority or any other form of entity.

“Plaza Booking Policy” shall have the meaning set forth in Section 6.1 of this Agreement.

“Plaza Event” shall have the meaning set forth in Section 5.4(c)(i) of this Agreement.

“Plaza License Agreement” shall have the meaning set forth in Section 6.1 of this Agreement.

“Plaza Naming Rights” shall have the meaning set forth in Section 7.7 of this Agreement.

“Plaza Naming Rights Partner” shall have the meaning set forth in Section 7.7 of this Agreement.

“Plaza Naming Rights Partner Exclusive Rights” shall have the meaning set forth in Section 7.7 of this Agreement.

“Plaza User” shall mean StadCo, Metro, the IDA Developer or any other Person who is authorized to use the Second Street Plaza for a Plaza Event pursuant to this Agreement.

“Plaza User’s Advertising” means the sale of advertising, sponsorship, signage, displays, and other promotional activity, in each case whether in form now existing or developed in the future that is located on any portion of the Second Street Plaza Area during a Plaza Event conducted by the Plaza User.

“Plaza User’s Advertising Rights” means the right to display, control, conduct, lease, permit, sell, publish and enter into agreements regarding the display of all Plaza User’s Advertising on any portion of the Second Street Plaza Site during a Plaza Event conducted by the Plaza User; provided, however, that with respect to any Plaza User other than StadCo, the exercise of any such right must (i) be directly related to such Plaza Event and not the primary purpose of such Plaza Event, (ii) not involve any permanent advertising, and (iii) be subject to the Plaza Naming Rights Partner Exclusive Rights.

“Plaza User’s Concession Rights” means the right to market, sell, display, distribute and store Plaza User’s Concessions and to conduct catering and banquet sales and service, on any portion of the Second Street Plaza Site during a Plaza Event conducted by the Plaza User; provided, however, that with respect to any Plaza User other than StadCo, the exercise of any such right must (i) be directly related to such Plaza Event and not the primary purpose of such Plaza Event, (ii) not involve any permanent advertising, and (iii) be subject to the Plaza Naming Rights Partner Exclusive Rights.

“Plaza User’s Concessions” means, collectively, all food and beverages, including all alcoholic beverages (subject to procurement of all necessary Government Approvals), and Plaza User’s Merchandise sold on any portion of the Second Street Plaza Site during a Plaza Event conducted by the Plaza User.

“Plaza User’s Data Rights” means the right to collect, use, sell, license, display, publish or otherwise use, names, contact information and other information with respect to those attending a Plaza Event conducted by the Plaza User

“Plaza User’s Hospitality Rights” means the right to market and sell hospitality assets on any portion of the Second Street Plaza Site during a Plaza Event conducted by the Plaza User, including, without limitation, tickets, experiences, Plaza User’s Concessions and Plaza User’s Merchandise; provided, however, that with respect to any Plaza User other than StadCo, the exercise of any such right must (i) be directly related to such Plaza Event and not the primary purpose of such Plaza Event, (ii) not involve any permanent advertising, and (iii) be subject to the Plaza Naming Rights Partner Exclusive Rights.

“Plaza User’s Merchandise” means souvenirs, apparel, publications, retail goods, other merchandise and other non-edible items, goods and wares sold on any portion of the Second Street Plaza Site during a Plaza Event conducted by the Plaza User.

“Preexisting Contract” shall have the meaning set forth in Section 7.6(b) of this Agreement.

“Preexisting Lease” shall have the meaning set forth in Section 7.6(a) of this Agreement.

“Premier Stadium Sponsors” means the Stadium Naming Rights Sponsor and the Cornerstone Sponsors.

“Premier Stadium Sponsorships” means the Stadium Naming Rights Sponsorship and the Cornerstone Sponsorships.

“Project Document” shall mean (i) the Declaration, and (ii) as to Metro and an IDA Ground Tenant and/or an IDA Ground Tenant Assignee only, the IDA Ground Lease for the IDA Parcel to which the IDA Ground Tenant and/or the IDA Ground Tenant Assignee is a party.

“Property” shall mean any interest in any kind of property or asset, whether real, personal or mixed, or tangible or intangible.

“Review and Approval Rights” shall have the meaning set forth in Section 10.1 of this Agreement.

“Second Resolution Deadline” shall have the meaning set forth in Section 11.2(b) of this Agreement.

“Second Street Plaza” shall have the meaning set forth in the Recitals of this Agreement.

“Second Street Plaza Land” means the Second Street Plaza Site.

“Second Street Plaza Site” shall mean the plaza area adjacent to the Stadium Site as shown on **Exhibit F**.

“Secondary Stadium Sponsor” shall mean one of up to twelve (12) Persons total that from time to time has been granted rights to any or all of the assets comprising a Secondary Stadium Sponsorship.

“Secondary Stadium Sponsorship” shall mean one of up to twelve (12) sponsorships (other than a Stadium Naming Rights Sponsorship or a Cornerstone Sponsorship) which shall have category exclusivity for any one or more categories agreed upon by StadCo and the applicable Secondary Stadium Sponsor.

“Senior Executives” shall have the meaning set forth in Section 11.2(a) of this Agreement.

“Senior Executives Meeting” shall have the meaning set forth in Section 11.2(a) of this Agreement.

“Separate Event” shall have the meaning set forth in Section 6.3(d) of this Agreement.

“Special Stadium Events” shall mean major Stadium Events at the Stadium such as Super Bowls, NCAA tournaments, and such other similar events that may require special accommodations, such as extended hours of operation, additional seating capacity, accommodation for media coverage, etc.

“StadCo” shall mean Tennessee Stadium, LLC, a Delaware limited liability company and shall have any additional meaning set forth in the preamble of this Agreement.

“StadCo Plaza Event” shall mean Stadium Events and Special Stadium Events pertaining to Second Street Plaza activation and all other activations of the Second Street Plaza by StadCo when the Stadium is not being used.

“StadCo Plaza Event Notice” shall mean a notice delivered by StadCo or the StadCo CCC member to Metro CCC Member and the IDA Developer Member advising that StadCo is booking the Second Street Plaza for use by StadCo, which notice shall be delivered in accordance with Article 6.

“StadCo Representative(s)” shall have the meaning set forth in Section 2.2 of this Agreement.

“StadCo’s Advertising Rights” means the right to display, control, conduct, lease, permit, sell, publish and enter into agreements regarding the display of all Advertising at, on or within the Stadium or any portion of the Second Street Plaza.

“StadCo’s Concessions” means, collectively, all food and beverages, including all alcoholic beverages (subject to procurement of all necessary Government Approvals), and StadCo’s Merchandise sold by StadCo at, on or within the Stadium or any portion of the Second Street Plaza.

“StadCo’s Concession Rights” means the right to market, sell, display and distribute Concessions and to conduct catering and banquet sales and service, including, but not limited to, catering sales and service with respect to private areas located in the Stadium (*e.g.*, private suites and media and broadcast areas) and at, on or within the Stadium or any portion of the Second Street Plaza.

“StadCo’s Data Rights” means the right to collect, use, sell, license, display, publish or otherwise use, names, contact information and other identifiable information with respect to those attending Stadium Events.

“StadCo’s Hospitality Rights” means the right to market and sell hospitality assets related to the Stadium during the Stadium Event Operational Period, including, without limitation, suites, tickets, experiences, StadCo’s Concessions and StadCo’s Merchandise.

“StadCo’s Merchandise” means souvenirs, apparel, publications (including NFL football programs), retail goods, other merchandise (including, but not limited to, NFL or team novelties and licensed items) and other non-edible items, goods, equipment (including mechanical, electrical or computerized amusement devices) and wares sold by StadCo and at, on or within the Stadium or any portion of the Second Street Plaza.

“Stadium” shall mean a new premier, first-class, fully-enclosed venue to be constructed on the Stadium Land for professional football Team Games and a broad range of other civic, community, athletic, educational, cultural, and commercial activities.



“Stadium Development Agreement” means that certain Development and Funding Agreement by and between the Authority and StadCo dated as of August 25, 2023.

“Stadium Event Operational Period” shall mean the period that is thirty-six (36) hours (or such reasonable lesser time as is feasible under the relevant circumstances) prior to the commencement of the Stadium Event and twenty-four (24) hours (or such reasonable lesser time as is feasible under the relevant circumstances) after the end of the Stadium Event, except for Special Stadium Event which shall be a period that is subject final determination by the CCC pursuant to Section 5.4(c)(v).

“Stadium Events” means Team Events, TSU Games and any and all other events or activities of any kind at the Stadium which are permitted under the Stadium Lease, excluding events hosted by the Authority, where tickets are distributed to more than 20,000 people and any events held at the Stadium by Tennessee State University pursuant to that certain TSU Agreement and Stadium Lease [New Stadium], dated as of August 25, 2023, by and between StadCo and Tennessee State University, acting for the benefit of the Tennessee State University Board of Trustees, as the same may be amended from time to time.

“Stadium Land” means the Stadium Site.

“Stadium Lease” shall mean the Stadium Lease Agreement dated as of August 25, 2023, between the Authority, as lessor, and StadCo, as lessee, and covering the Stadium Land and the Stadium, as the same may be amended, supplemented, modified, renewed or extended from time to time as provided therein.

“Stadium Naming Rights” shall mean the right to name and rename the Stadium.

“Stadium Naming Rights Sponsor” means any Person that from time to time holds Stadium Naming Rights with respect to the Stadium through an agreement with StadCo.

“Stadium Rights” shall have the meaning set forth in Section 3.2 of this Agreement.

“Stadium Site” shall have the meaning set forth in the Recitals of this Agreement.

“State” shall mean the State of Tennessee.

“Team” shall mean the National Football League franchise currently known as the Tennessee Titans.

“Team Events” shall mean events at the Stadium, in addition to Team Games, that are related to the football operations of the Team or the marketing or promotion of the Team.

“Team Games” shall mean each pre-season, regular season and play-off NFL game of the Team in which the Team is designated by the NFL as the “home” team, excluding any Super Bowl, even if held at the Stadium.

“TeamCo” shall mean Tennessee Football, LLC, a Delaware limited liability company.

“Temporary Facilities” shall mean all exhibits, booths, staging, rigging, partitions, seating, signs and banners, decorative materials, furniture, furnishings, equipment and other temporary structures or installations placed or used by a Plaza User in the Second Street Plaza and/or Campus Park.

“TSU” shall mean Tennessee State University.

“TSU Games” shall mean TSU football games played at the Stadium pursuant to the TSU Lease.

“TSU Lease” shall mean the lease agreement between StadCo and TSU establishing certain rights with respect to TSU’s use of the Stadium.

“Traffic Plan” shall have the meaning set forth in Section 8.2 of this Agreement.

## RULES AS TO USAGE

1. The terms defined above have the meanings set forth above for all purposes, and such meanings are applicable to both the singular and plural forms of the terms defined.
2. “Include,” “includes,” and “including” shall be deemed to be followed by “without limitation” whether or not they are in fact followed by such words or words of like import.
3. “Writing,” “written,” and comparable terms refer to printing, typing, and other means of reproducing in a visible form.
4. Any agreement, instrument or Applicable Law defined or referred to above means such agreement or instrument or Applicable Law as from time to time amended, modified or supplemented, including (in the case of agreements or instruments) by waiver or consent and (in the case of Applicable Law) by succession of comparable successor Applicable Law and includes (in the case of agreements or instruments) references to all attachments thereto and instruments incorporated therein.
5. References to a Person are also to its permitted successors and assigns.
6. Any term defined above by reference to any agreement, instrument or Applicable Law has such meaning whether or not such agreement, instrument or Applicable Law is in effect.
7. “Hereof,” “herein,” “hereunder,” and comparable terms refer, unless otherwise expressly indicated, to the entire agreement or instrument in which such terms are used and not to any particular article, section or other subdivision thereof or attachment thereto. References in an instrument to “Article,” “Section,” “Subsection” or another subdivision or to an attachment are, unless the context otherwise requires, to an article, section, subsection or subdivision of or an attachment to such agreement or instrument. All references to exhibits or appendices in any agreement or instrument that is governed by this Appendix are to exhibits or appendices attached to such instrument or agreement.
8. Pronouns, whenever used in any agreement or instrument that is governed by this Appendix and of whatever gender, shall include natural Persons, corporations, limited liability companies, partnerships, and associations of every kind and character.
9. References to any gender include, unless the context otherwise requires, references to all genders.
10. “Shall” and “will” have equal force and effect.
11. Unless otherwise specified, all references to a specific time of day shall be based upon Central Standard Time or Central Daylight Savings Time, as applicable on the date in question in Nashville, Tennessee.
12. References to “\$” or to “dollars” shall mean the lawful currency of the United States of America.

## **EXHIBIT B**

### **CAMPUS**

#### Parcel Numbers

09302006800  
08215003000  
09303002200  
09302008700  
09303006600  
09303017400  
09303015300  
09307001000  
09303017100  
09303011500  
09307004600  
09307005100

Such parcels being lots 2, 3, 4, 5, 8, 9, 10, 11, and 12 on the Phase Two Subdivision Plat, Tennessee NFL Stadium, East Bank Redevelopment Plan, of record in Book 9700, Pages 986 and 987, R.O.D.C., and lots 13 and 14A on the Unified Plat of Subdivision of Lots 6, 13 & 14 of the Phase Two Subdivision Plat, Tennessee NFL Stadium, East Bank Redevelopment Plan, of record at Instrument No. 20100929-0077565, R.O.D.C., and lot 15 on the Resubdivision to Phase 2 Lot 15, Tennessee NFL Stadium, East Bank Redevelopment Plan, of record at Instrument No. 20100924-0076276, R.O.D.C., and further having been conveyed to Metro by deed of record at Instrument No. 20230901-0068581, R.O.D.C.

EXHIBIT C  
STADIUM SITE

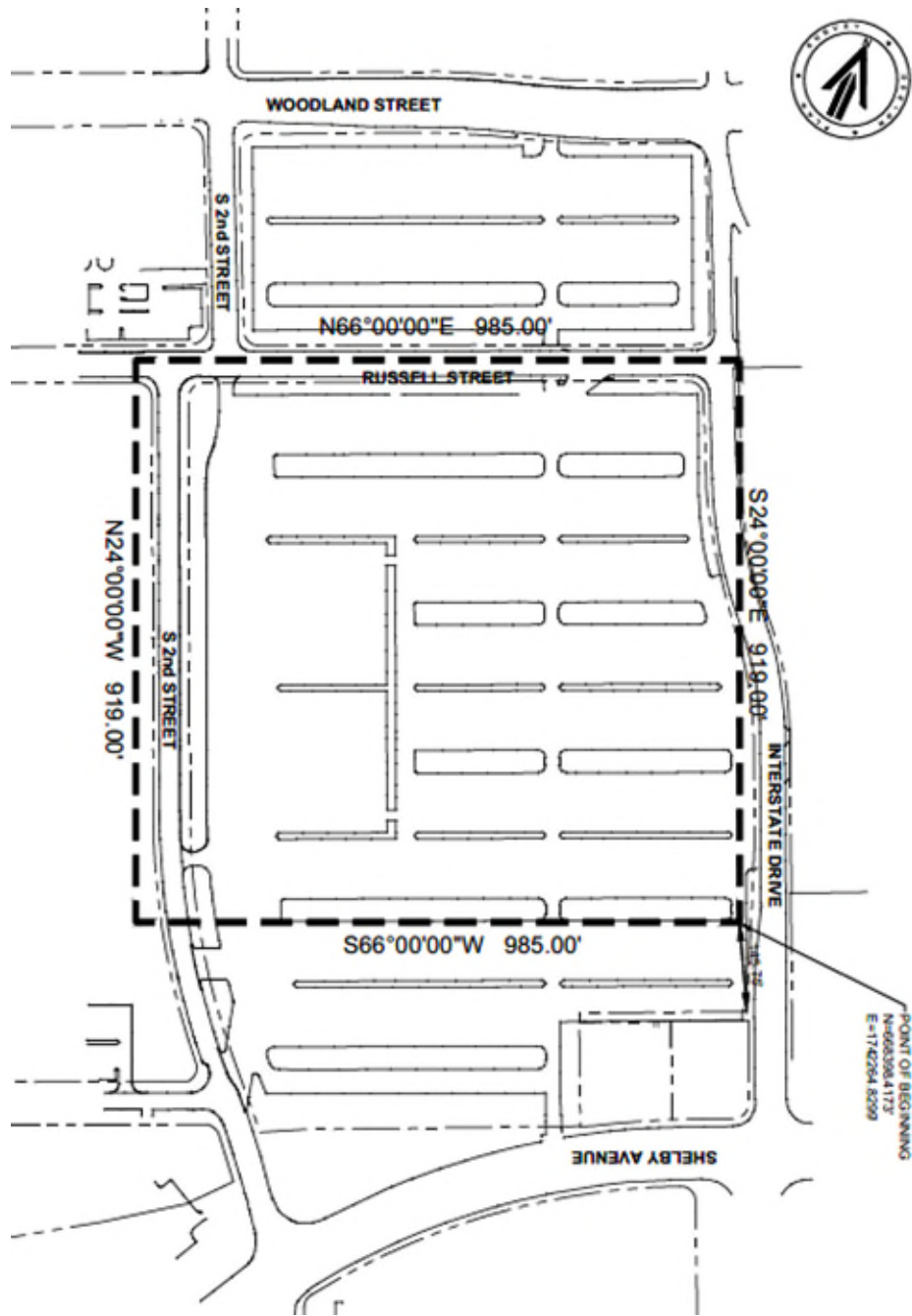

Being a 100' Buffer Yard surrounding the proposed Titans Stadium. Said stadium is located in the 6<sup>th</sup> Council District of Nashville, Davidson County, Tennessee. Said Stadium is located on a part of Lot 8 and 9 as shown on the plat entitled, Tennessee NFL Stadium, of record in Plat Book 9700, page 986, Register's Office for Davidson County, Tennessee. Said lots were conveyed to The Sports Authority of the Metropolitan Government of Nashville and Davidson County, of record in Deed Book 11634, page 297, Register's Office for Davidson County, Tennessee. Said buffer is hereby described as follows:

Beginning at a point 145.75 feet northwest of the southeasterly corner of said Sports Authority, with State Plane coordinates of: N=668398.4173', E=1742264.8299';

Thence, crossing said Sports Authority and S 2<sup>nd</sup> Street, South 66°00'00" West, 985.00 feet to a point;

Thence, continuing to cross said Sports Authority and Russell Street, North 24°00'00" West, 919.00 feet to a point;

Thence, continuing to cross Russell Street and Interstate Drive, North 66°00'00" East, 985.00 feet to a point;

Thence, continuing to cross Interstate Drive and said Sports Authority, South 24°00'00" East, 919.00 feet to the point of beginning and containing 905,215 square feet or 20.78 acres, more or less.

## **EXHIBIT D**

### **EXISTING STADIUM SITE**

That certain parcel of real property located at 1 Titans Way, Nashville, Tennessee 37213, bounded on the north by Russell Street, on the east by Second Street, on the south by Victory Avenue and on the west by Titans Way, consisting of approximately 32 acres as shown on **Exhibit E**.

**EXHIBIT E**  
**INITIAL DEVELOPMENT AREA**





**EXHIBIT F**

**LOCATION OF SECOND STREET PLAZA SITE**

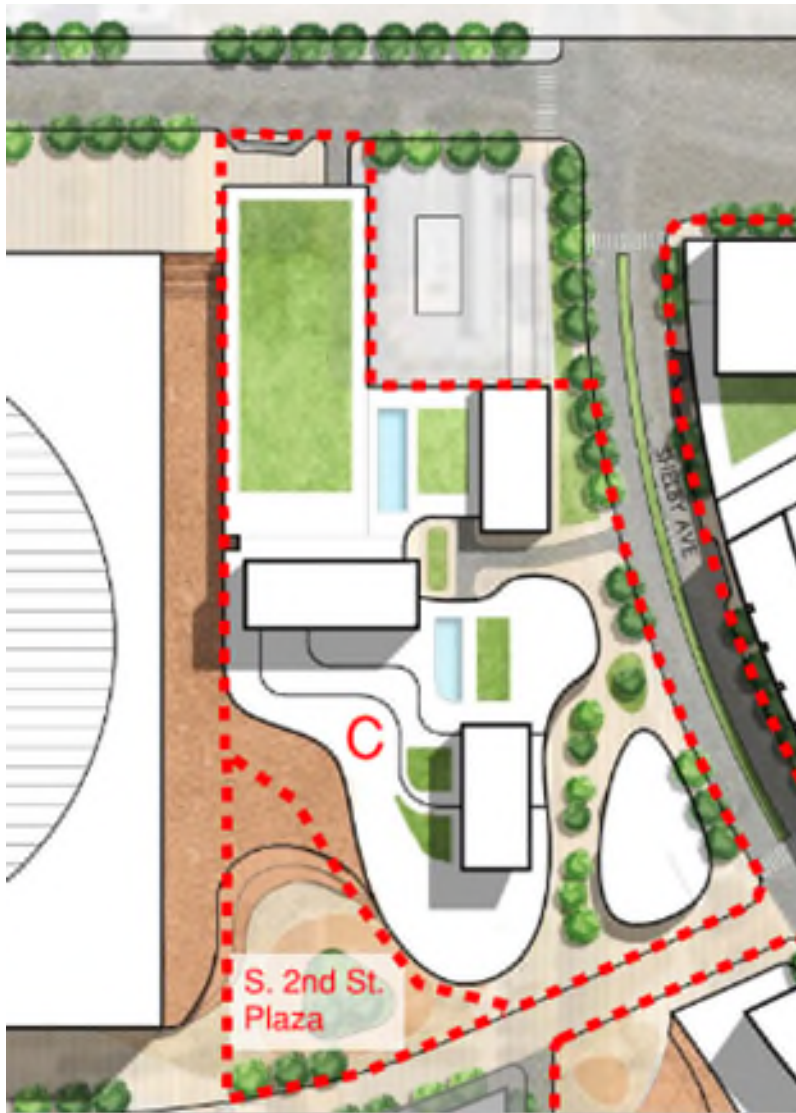

**EXHIBIT G**  
**LOCATION OF PARCEL B EASEMENT AREA**

[To be attached]

37383914.1

This Instrument Prepared By:

Richard R. Spore, III  
Bass, Berry & Sims PLC  
The Tower at Peabody Place  
100 Peabody Place, Suite 1300  
Memphis, TN 38103-3672

**DECLARATION OF EASEMENTS, RESTRICTIONS AND COVENANTS  
FOR PARCEL B, THE STADIUM PLAZA, PARCEL C, EAST BANK**

This **DECLARATION OF EASEMENTS, RESTRICTIONS AND COVENANTS** (this “Declaration”) is made and entered into as of \_\_\_\_\_, 2024 (“Effective Date”), by the THE METROPOLITAN GOVERNMENT OF NASHVILLE AND DAVIDSON COUNTY, a Tennessee municipal corporation (“Metro”; Metro, together with its successors and assigns, “Declarant”).

**RECITALS:**

A. Declarant holds record title to the real property located in the City of Nashville, Davidson County, Tennessee, which (1) is depicted as Parcel B (“Parcel B”) on the site plan attached hereto as Exhibit A-1.A and incorporated herein by reference (the “Parcel B Site Plan”) and is depicted as Parcel C (“Parcel C”) on the site plan attached hereto as Exhibit A-1.B and incorporated herein by reference (the “Parcel C Site Plan”; the Parcel B Site Plan and the Parcel C Site Plan are sometimes collectively referred to herein as the “Site Plan”), and (2) is more particularly described on Exhibits B-1.A and B-1.B to this Declaration and incorporated herein by reference.

B. Declarant, as ground lessor, has ground leased to the The Sports Authority of the Metropolitan Government of Nashville and Davidson County (the “Sports Authority”), and Sports Authority has ground leased to StadCo, for development of a stadium, land adjacent to Parcels B and C, which is depicted a “Stadium Parcel” on the Site Plan and is more particularly described on Exhibit B-2 to this Declaration.

C. Declarant, as ground lessor, intends to ground lease for development by one or more third party developer(s) that portion of Parcel C more particularly described on the Site Plan and Exhibit B-3 to this Declaration and incorporated herein by reference (“Parcel C Development Area”).

D. StadCo, defined below, has agreed to fund the Plaza Improvements, defined below, which are necessary to prepare and improve that portion of Parcel C depicted on the Site Plan and more particularly described on Exhibit B-4 attached to this Declaration and incorporated herein by reference (the “Plaza Land”) as a privately-operated, publicly accessible open space plaza (the “Plaza”). The Plaza Land and Plaza Improvements are sometimes referred to herein collectively as the “Plaza Property”.

E. StadCo’s agreement to fund the construction and ongoing operation of the Plaza is in consideration for the expected benefits accruing to the Stadium, defined below, including (i) Activation, defined below, in connection with Stadium events and otherwise, (ii) the provision of ingress to, egress from, and access to and from the public streets and sidewalks adjacent to the Plaza, and (iii) Declarant’s provision of the use of a portion of Parcel B for the purposes described herein.

F. In consideration thereof, Metro now desires to establish by this Declaration a series of easements and other rights and obligations on Parcel B, Parcel C and the Stadium Parcel for the benefit of StadCo and the Parcel C Development Owners, including certain easement rights and obligations to use the Plaza, all as set forth below.

## **AGREEMENTS:**

NOW, THEREFORE, Declarant hereby establishes the following obligations, restrictions, covenants, and other encumbrances upon the Stadium Parcel, Parcel B and Parcel C pursuant to which Parcel B and Parcel C, together with easement and leasehold interests therein, shall be hereafter held, used, occupied, to the extent permitted by the terms and conditions of the Ground Leases and other applicable Requirements, defined below.

### **ARTICLE I**

#### **DEFINITIONS**

1.1 Defined Terms. Capitalized words or phrases, when used in this Declaration, unless the context shall otherwise clearly indicate or prohibit, shall have the meanings set forth in the Appendix attached hereto and incorporated by reference herein. All capitalized terms used in this Declaration that are not defined in the Appendix shall have the meanings contained elsewhere in this Declaration.

### **ARTICLE II**

#### **PROPERTY SUBJECT TO THIS DECLARATION**

2.1 Property Hereby Subjected to this Declaration. The real property which is, by the recording of this Declaration, subject to the covenants, conditions, restrictions and easements herein set forth and which, by virtue of the recording of this Declaration, shall be held, transferred, sold, conveyed, used, occupied, and encumbered subject to this Declaration is Parcel C described in Exhibit B-1.A, B-3 and B-4 and Parcel B described in Exhibit B-1.B attached hereto and by this reference made a part hereof.

### **ARTICLE III**

#### **EASEMENTS FOR THE PLAZA AND PARCEL C**

3.1 StadCo Plaza Easement. Subject to the rights of the Parcel C Development Owners as hereinafter provided and all Exceptions, Requirements, and the terms and conditions of this Declaration, Declarant hereby grants to StadCo, for the use and benefit of StadCo and its Benefited Parties, a non-exclusive easement on, over and across the Plaza Land and other applicable portions of Parcel C (the "StadCo Easement") for the following purposes during the StadCo Easement Term:

- (a) Construction, operation, management, maintenance, repair and, if necessary, replacement of the Plaza Improvements, subject to and in accordance with the Requirements;
- (b) Utilization of the Plaza for ingress and egress by StadCo and StadCo's Benefited Parties, to and from the Stadium and public roads and sidewalks adjacent to the Plaza;

(c) The Activation of the Plaza subject to and in accordance with the Requirements;  
and

(d) The operation and maintenance of the Plaza as a privately-owned public space consistent with the Use Guidelines (the “Community Purpose”), including keeping the Plaza open and available to the general public for purposes limited to pedestrian and bicycle access and passage to public streets and sidewalks adjacent to the Plaza, temporary gathering, and other typical uses for open space and neighborhood plazas, subject to and in accordance with the Requirements.

(e) The encroachment by the Stadium loading ramp onto, over and across those portions of Parcel C more particularly described on Exhibit C attached hereto and incorporated herein by reference.

(f) The encroachment of stairs and other appurtenances to the Stadium upon the Plaza Land, substantially as may be initially constructed.

Notwithstanding the foregoing, the fifteen (15)-foot-wide area of the Plaza adjacent to the Parcel C Development Area shown on the Site Plan as the Plaza Side-Line Area (the “Plaza Side-Line Area”) will be the subject of a Ground Lease from Metro to a Parcel C Development Owner and shall be reserved for the use of the applicable Parcel C Development Owner’s restaurant and other food and beverage retail tenants solely for their temporary outdoor seating and queues (the “Outdoor Seating Purpose”) and shall not be used for any other purpose or use, including without limitation the following: (1) the installation or location of any permanent or temporary structure, (2) the sale of food, alcoholic beverages or other beverages for consumption outside of the Plaza Side-Line Area, (3) the cooking of food, (4) the solicitation of customers or display of food, (5) any use which permits the sale of alcoholic beverages, that may be carried from the Plaza Side-Line Area onto other portions of the Plaza, or in disposable containers, or (6) the temporary or permanent storage of furniture or equipment, other than the temporary storage of tables and chairs used within the Plaza Side-Line Area in a neat and slightly condition, provided that they are removed from the Plaza Side-Line Area during extended periods of non-use. To the extent not used for the Outdoor Seating Purpose, the Plaza Side-Line Area shall be available for pedestrian circulation by and between the Parcel C Development Area, adjacent retail and restaurant tenants and the other areas of the Plaza. As the Plaza Side-Line Area is the subject of a Ground Lease to a Parcel C Development Owner, StadCo shall have no obligation to observe or enforce any obligations under this Declaration with respect to any use of the Plaza Side-Line Area other than its own or those of its Benefited Parties. This Declaration shall be recorded prior to the recordation of any such Ground Lease and StadCo’s or any of its licensees’ use of the Plaza Side-Line Area shall not be subject to the terms and conditions of such Ground Lease.

3.2 Character of StadCo Easement. Except as set forth in this Declaration the StadCo Easement granted herein is for the sole and exclusive use of StadCo and its Benefited Parties, and shall not be construed in any manner to create or grant any rights to the public generally, to any other person or entity, or to any other Owner to use or enter upon the Plaza. Except as expressly set forth in this Declaration or in the Campus Use Agreement, StadCo shall not have the right to lease or otherwise permit the use of the Plaza Property by any other person or entity, nor assign any of the rights, privileges, duties or obligations of StadCo hereunder, without the prior written consent of Declarant; provided, StadCo shall have the right to assign its rights, privileges, duties and obligations hereunder in connection with a Permitted Assignment

under the Stadium Lease to the same Person that is the permitted transferee pursuant to such Permitted Assignment.

3.3 Duration of StadCo Easement. The term of the StadCo Easement shall commence on the Effective Date of this Declaration and, except as otherwise expressly provided herein, shall expire upon the expiration or earlier termination of the Stadium Lease unless extended by Metro in writing in its sole discretion (“StadCo Easement Term”). Notwithstanding the expiration of the Stadium Lease term or the earlier termination of the StadCo Easement, the respective rights and obligations of the Declarant and StadCo that are expressly intended to survive such expiration or earlier termination shall accordingly survive.

3.4 Extension of StadCo Easement Rights. Notwithstanding anything herein to the contrary, upon the expiration or earlier termination of the StadCo Easement Term (as the same may be extended by Metro), the rights, benefits and obligations set forth in paragraphs (a)-(d) of the StadCo Easement in Section 3.1 shall (unless written election to terminate the StadCo Easement Term is given to Declarant by the Ground Lessee of the Parcel C Development Area) inure to the benefit of the Ground Lessee of the Parcel C Development Area for the remainder of the term of its Ground Lease, in accordance with the terms and conditions of the Campus Use Agreement; provided that if there are more than one such Ground Lessees of the Parcel C Development Area, then such Ground Lessees shall designate one Ground Lessee to make this election, and if they cannot agree upon such designee, then the Ground Lessee with the longest border with the Plaza shall be deemed the appropriate Ground Lessee for these purposes. For purposes of clarity, the Ground Lessee(s) of the Parcel C Development Area shall be permitted successor(s) of StadCo for purposes of exercising such Ground Lessee(s)’ rights and discharging their obligations pursuant to this Section 3.4 and for purposes of Section 4.1(c) below.

3.5 As-Is Conveyance. BY ITS ACCEPTANCE OF THE STADCO EASEMENT CONVEYANCE, AND AS A MATERIAL PART OF THE CONSIDERATION, STADCO AGREES THAT STADCO HAS ACCEPTED THE EASEMENT INTERESTS IN THE PLAZA PROPERTY IN ITS CURRENT, "AS IS, WHERE IS" CONDITION "WITH ALL FAULTS," AND HAS ASSUMED THE RISK OF ANY MATTER OR CONDITION WHICH IS LATENT OR PATENT OR THAT COULD HAVE BEEN REVEALED BY ITS INVESTIGATIONS. DECLARANT HAS NOT MADE (AND DECLARANT HEREBY EXPRESSLY DISCLAIMS, AND DECLARANT IS CONVEYING THE STADCO EASEMENT WITHOUT) ANY REPRESENTATIONS OR WARRANTIES, EXPRESS OR IMPLIED, WHATSOEVER AS TO THE TITLE, VALUE, CONDITION, NATURE, CHARACTER, SUITABILITY, HABITABILITY OR FITNESS OF THE PLAZA PROPERTY, THE INCOME TO BE DERIVED THEREFROM, THE PRESENCE OR ABSENCE OF ANY HAZARDOUS MATERIAL OR OTHER ENVIRONMENTAL CONDITION OR COMPLIANCE OF THE PLAZA PROPERTY WITH, OR VIOLATION OF, ANY LAW, STATUTE, ORDINANCE, RULE OR REGULATION, AND ANY OF SUCH REPRESENTATIONS AND WARRANTIES, AND ANY CLAIMS OR CAUSES OF ACTION AGAINST DECLARANT BASED IN WHOLE OR IN PART ON ANY VIOLATION OF, OR ARISING WITH RESPECT TO, ANY FEDERAL, STATE OR LOCAL STATUTE, ORDINANCE, RULE OR REGULATION ARE HEREBY EXPRESSLY WAIVED AND RELEASED BY STADCO.

3.6 Public Use Easements. There is hereby reserved to the Declarant and its Benefited Parties, the Public Use Easement over the Plaza for Public Use Events.

## ARTICLE IV

### RESTRICTIONS ON USE OF THE PLAZA

#### 4.1 Use Restrictions.

(a) Use Guidelines. In addition to the Requirements, the Plaza shall be subject to any applicable Use Guidelines.

(i) After initial construction of the Plaza Improvements is substantially complete, StadCo shall, at all times thereafter during the StadCo Easement Term, operate and maintain the Plaza for the Community Purpose, subject to the following exceptions as well as the other applicable provisions contained in this Declaration and/or any Requirements:

(1) StadCo shall have the right, at any time and from time to time, to exclude and restrain any person or entity from (A) exhibiting any placard, sign or notice, (B) distributing any circular, handbill, placard or booklet, (C) soliciting memberships, signatures or contributions for private, civic, public, charitable or political purposes, (D) parading, picketing or demonstrating, or (E) failing to follow reasonable rules and regulations established by StadCo relating to the use and operation of the Plaza, including reasonable hours of operation.

(2) StadCo shall have the right to temporarily close off portions of the Plaza and/or to erect or place barriers in and around areas on the Plaza Land (including, without limitation, the Plaza) in accordance with the terms and conditions of the Campus Use Agreement.

(b) Prohibited Uses and Other Limitations. Uses of the Plaza, or any portion thereof, shall be restricted as indicated below.

(i) Uses on the Plaza shall be (i) limited to Permitted Uses, and (ii) subject to all Zoning Conditions and other Requirements.

(ii) StadCo shall not permit anything within its reasonable control to be done or kept in, on, or about the Plaza that violates any applicable law, including without limitation any Zoning Conditions or other applicable Requirements relating to use of the Plaza.

(iii) No dangerous or unsafe uses such as handling, storing or otherwise dealing with explosives shall take place on the Plaza to the extent such activities pose an immediate threat to any other Parcel or materially and adversely affect another Owner's intended use of its respective Parcel.

(iv) Neither Declarant nor StadCo shall construct any buildings, permanent structures, or other permanent vertical improvements within the Plaza (the "No Build Restriction"); provided, however, that this No Build Restriction shall not prevent the Plaza from being used as or improved with sidewalks, plazas, patios, walkways, other surface hardscapes; green space, planters, plantings, trees, shrubs, other landscaping features; and/or benches, tables, chairs, fences, irrigation systems, and/or signage. If any structure located on the Plaza to which the Declarant has not consented to in accordance with this

paragraph impairs the Community Purpose, then following reasonable prior notice to StadCo and a reasonable opportunity to cure, the Declarant may remove such structure at StadCo's expense.

(v) No goods, equipment or other materials may be stored on any portion of the Plaza outside of a building or structure in such a manner as to be visible from any street or any portion of the Parcel C Development Area, and no temporary structure, tent, shack or barn of any kind shall be erected, or placed upon the Plaza, except in connection with the Activation of the Plaza, in which case any such materials may be stored and/or any such structure may be maintained no longer than is necessary for such Activation. In addition, construction and development operations and activities may be conducted on the Plaza and, in connection therewith, all things reasonably necessary or convenient in order to most expeditiously commence, continue and complete such construction and development operations (specifically including, but not limited to, construction and maintenance of temporary buildings and trailers for storage of construction materials and equipment and open storage of uncovered building materials and equipment) shall be done.

(vi) No noxious or offensive activity shall be conducted on the Plaza, nor shall anything be done thereon which may be or may become a nuisance to the other Owners.

(vii) In addition to and without limiting any of the foregoing, all of the Prohibited Uses are prohibited on the Plaza.

(viii) The Activation of the Plaza and the Parcel B Easement Area shall comply with any restrictions regarding obstruction and access and visibility set forth in the Campus Use Agreement.

(c) Continuation. For purposes of clarity, the provisions of this Section 4.1 shall survive the expiration of the Stadium Lease Term and of the StadCo Easement Term, for the entire Term as to permitted successors and assigns of StadCo.

Section 4.2 Construction of Improvements. Construction of Improvements on the Plaza shall be performed in a good and workmanlike manner, in compliance with all applicable Governmental Requirements, the Development-Wide Standard, the terms and conditions of this Declaration, and all other applicable Requirements. Construction of Improvements on the Plaza must be commenced, prosecuted and completed as set forth in the Stadium Development Agreement.

Section 4.3 Maintenance Obligations. Subject to the terms and provisions hereof, StadCo shall have a duty and responsibility, at StadCo's sole cost and expense, at all times during the StadCo Easement Term to keep the Plaza and all Improvements thereon in a well-maintained, safe, and clean condition, in accordance with all applicable Requirements, at all times. StadCo shall maintain landscaping on the portion of the Plaza that is not covered by other Improvements. The foregoing obligations shall include, without limitation, the following:

(a) StadCo shall maintain in good order and repair, and at its own expense, all Plaza Improvements (including, without limitation, all walkways, paving, curbs and gutters) and all fixtures, furniture, facilities, and equipment located on the Plaza or otherwise serving the Plaza, in accordance with all applicable Governmental Requirements and other applicable Requirements.

(b) To the extent not required to be maintained by public utilities companies or Metro, StadCo shall maintain all fire hydrants and the associated water lines, valves, meters and other



Utilities and all areas utilized for Utilities Easements located on the Plaza, in accordance with all applicable Governmental Requirements;

(c) All landscaping shall be properly maintained in an attractive and neat manner (including without limitation regular mowing) in accordance with all Requirements and generally consistent with both the Development-Wide Standard and the quality, quantity, condition and types of landscaping generally used in the remainder of the Project and shall be kept free of any dead or diseased plant material;

(d) StadCo shall promptly remove all litter, trash, debris, filth, refuse, and waste from the Plaza;

(e) StadCo shall maintain in working order and illuminating during darkness, exterior lighting, including any pole lighting located on the Plaza; and

(f) Subject to the provisions of Sections 4.2 and 4.6 hereof and any other applicable Requirements, StadCo shall promptly repair any damage to any Improvements located on the Plaza.

Section 4.4 Signage. All signs erected on the Plaza after the date hereof shall be in accordance with all applicable Governmental Requirements and any other applicable Requirements.

Section 4.5 Environmental. Neither StadCo nor its Benefited Parties shall knowingly store, discharge, or dispose of on or about the Plaza (or any portion thereof), or knowingly permit the storage, discharge or disposal on or about the Plaza (or any portion thereof) of, any Hazardous Materials to the extent such storage, discharge or disposal is in violation of applicable law.

Section 4.6 Restoration. Subject to any other applicable Requirements, StadCo shall promptly, at its cost, repair, restore or rebuild any Improvements on the Plaza that are destroyed or damaged by fire or other cause, to the extent necessary to cause the Plaza to adhere to the Development-Wide Standard. Notwithstanding anything herein to the contrary, any such repair, restoration or construction shall be performed in accordance with Section 4.2 hereof.

Section 4.7 Rules and Regulations. Subject to Zoning Conditions, other Governmental Requirements and other Requirements, the Declarant may, from time to time, promulgate, modify or delete reasonable rules and regulations applicable to the Plaza; provided, however, the Declarant shall not adopt any rules or regulations which impose a greater restriction on the use or development of the Plaza than the other Requirements, unless (x) agreed to in writing by the Owner(s) of the Plaza and by the Parcel C Development Owners or (y) otherwise consistent with the rules, regulations and practices of stadium-anchored, mixed-use developments similar to the Project. Such rules and regulations shall be distributed to StadCo and Parcel C Development Owners prior to the date that they are to become effective and shall thereafter be binding upon StadCo and its Benefited Parties until and unless overruled, waived, canceled or modified by the Declarant. StadCo shall have the right to promulgate, modify or delete reasonable rules and regulations applicable to the Plaza which are in addition to, or more restrictive than, those of Metro that apply to StadCo's Benefitted Parties' use of the Plaza, so long as they do not violate the Community Purpose and subject to the provisions of this Declaration and compliance with the Requirements.

**ARTICLE V**  
**ADDITIONAL EASEMENTS AND AGREEMENTS**

5.1 Parcel C Development Owners Plaza Ingress-Egress Easement. Declarant hereby grants a non-exclusive easement to the Parcel C Development Owners for the use and benefit of the Parcel C Development Owners and their Benefited Parties for ingress and egress on, over and across the Plaza Land and the Plaza after its construction to and from the Parcel C Development Area, the public roads and the sidewalks adjacent to the Plaza.

5.2 Pedestrian Access Easement over Parcel C Development Area. Declarant hereby agrees to grant or reserve a non-exclusive pedestrian ingress and egress easement for the use and benefit of StadCo, the StadCo Benefited Parties and the general public on the Parcel C Development Area in a location to be identified in the Plan of Easements, providing access to and from the Stadium Platform to and from Shelby Street and connecting to any public or Stadium parking garage that may be constructed on Parcel C.

5.3 Pedestrian and Bicycle Access Easement over Cumberland Walk. Declarant hereby grants and reserves (for the limited purpose of satisfying the Community Purpose) a non-exclusive pedestrian and bicycle ingress and egress easement for the use and benefit of the general public on, over and across the Cumberland Walk, providing access to and from the Plaza and adjacent public sidewalks and streets. The Cumberland Walk located on Parcel C shall be maintained in good condition and repair by the Parcel C Development Owner(s) at their sole expense, in accordance with all applicable Requirements.

5.4 Parcel C Development Owners Access Easement to Stadium Platform. Declarant hereby grants a non-exclusive easement to the Parcel C Development Owners for the use and benefit of the Parcel C Development Owners and their Benefited Parties for pedestrian ingress and egress directly from the Improvements constructed on Parcel C Development Area to and from the Stadium Platform, in locations to be identified in the Plan of Easements, provided that such right of access shall be subject in all respects to compliance with security requirements and the rules and regulations of the National Football League, and does not include the right to use any portion of the Stadium Platform.

5.5 Interstate Drive Shared Access Easement. Declarant hereby agrees to grant or reserve one or more construction and access easements for the use and benefit of StadCo, the StadCo Benefited Parties and, as applicable, the Parcel C Development Owners and their Benefited Parties, for construction of an access ramp and vehicular access to the Improvements located on such portion of Parcel C and the Stadium in a location and configuration to be identified in the Plan of Easements. Such access shall be exclusive or non-exclusive, based upon the location of the easement and the reasonable access needs of the benefited parties and shall be memorialized in the Plan of Easements pursuant to Section 5.10 below.

5.6 Stormwater and Utilities Easements. Declarant hereby grants to Parcel C Development Owners an easement to access, upon reasonable prior written notice, the water, sanitary sewer and stormwater sewer utilities that may be constructed under the Plaza or under the Stadium Platform in a reasonably convenient location to be identified in the Plan of Easements to serve the Improvements on the Parcel C Development Area, to the extent that such access or work performed in connection with such access does not materially disrupt StadCo's use of the Stadium or the Plaza. Parcel C Development Owners shall be solely responsible for the cost of the connection and restoring the property to the same condition as existed prior to the Parcel C Development Owners' (or their Benefited Parties') performance of any such work. Declarant also hereby grants to StadCo and the Parcel C Development Owners the right at their expense to connect to utilities located in the public streets and rights of way adjacent to Parcel C in compliance with Metro's Requirements applicable thereto.

5.7 Rights. Each Parcel C Development Owner shall have the right, at any time and from time to time, to:

(a) exclude and restrain any person or entity from (i) exhibiting any placard, sign or notice, (ii) distributing any circular, handbill, placard or booklet, (iii) soliciting memberships, signatures or contributions for private, civic, public, charitable or political purposes, or (iv) parading, picketing or demonstrating, in each case in the areas provided for easements under this Declaration and

(b) construct, locate and relocate Improvements, and to arrange and rearrange parking areas and walkways, upon such Owner's respective portion of Parcel C, and to close the same (or portions thereof) temporarily for repairs or to prevent a dedication thereof or the accrual of prescriptive rights therein; provided, however, that reasonable pathways for ingress and egress for access to and from the Plaza and the Stadium (including without limitation over and across the Cumberland Walk) must be maintained at all times.

5.8 Temporary Construction Easement. There is hereby reserved to the applicable Owner of the Parcel C Development Area, its employees, contractors and agents, a non-exclusive temporary construction easement (the "Temporary Easement"), over, under, on and upon the area shown and labeled as such on Exhibit B-7 hereto (the "Temporary Easement Area") for the express purpose of enabling the construction of the Improvements on the Parcel C Development Area adjacent to the Temporary Easement Area (the "Neighboring Improvements"), connecting the Neighboring Improvements to the Improvement in the Temporary Easement Area as appropriate, and for no other purpose, including without limitation, staging of construction, and erection of scaffolding on the Temporary Easement Area, at the sole cost and expense of the applicable Owner of the Parcel C Development Area. Such use of the Temporary Easement Area shall not interfere with StadCo's or Metro's or any of their Benefited Parties' use of the Plaza to more than a de minimis extent. The Owner of the Parcel C Development Area shall maintain the Temporary Easement Area in a clean, safe and sightly condition, with appropriate screening of materials and equipment. Any scaffolding that the Owner of the Parcel C Development Area erects upon the Temporary Easement Area shall exist only when such scaffolding is being actively and routinely used for construction purposes. If such scaffolding has not been so used for a period of more than five (5) consecutive business days, subject to extension of such period for Excusable Delays, the Owner of the Plaza shall have the right to require the Parcel C Development Area Owner to completely remove such scaffolding for a period of at least ten (10) days in the event that the actual and routine use of such scaffolding for construction purposes does not commence within two (2) business days' of its receipt of written notice from the Owner of the Plaza. The applicable Owner of the Parcel C Development Area shall promptly restore any damage or destruction arising from its use of the Temporary Easement. The Temporary Easement shall commence upon the later of: (a) commencement of construction of the Neighboring Improvements, and (b) ten (10) days following the date of delivery of written notice of the impending commencement from the applicable Owner of the Parcel C Development Area to the Owner of the Plaza, provided that the construction of the Neighboring Improvements may be undertaken in phases, in which event such commencement requirement shall be per phase. The Temporary Easement shall automatically terminate and expire upon the earlier of (y) completion of the construction of the Neighboring Improvements (and if undertaken in phases, then per phase), as evidenced by the issuance of a certificate of use and occupancy with respect thereto by Metro. Upon termination, and at the request of the Owner of the Plaza, the Owner of the Parcel C Development Area shall promptly deliver to the Owner of the Plaza an executed and recordable termination agreement with respect to the Temporary Easement.

5.9 Parcel B Encroachment, Access and Use Easements.

(a) Declarant hereby reserves unto to itself and StadCo an easement upon the Parcel B Easement Area for the encroachment of a stairway, ramps and other Stadium appurtenances over the boundary line of the Premises and onto the Parcel B Easement Area, substantially as may be initially constructed.

(b) Declarant hereby reserves unto itself, StadCo and their respective Benefited Parties, for the benefit of the Stadium Parcel, nonexclusive right, privilege and easement along, over and across the Parcel B Easement Area for the purpose of providing pedestrian access, ingress and egress to, from and between the demised Premises under Stadium Lease, the balance of Parcel B and the public rights-of-way adjacent to either of the foregoing, without payment of any fee or other charge being made therefor. The foregoing pedestrian access easement may be used by StadCo and its Benefited Parties. Declarant agrees not to obstruct or interfere in any way with the free flow of pedestrian traffic from the Parcel B Easement Area to the remainder of Parcel B or the public rights-of-way adjacent to either of the foregoing at any time except on a temporary basis to the extent legally necessary to prevent a dedication thereof or the accrual of any rights to the public therein or to make necessary repairs.

(c) Declarant hereby reserves to StadCo for the benefit of the Stadium Parcel, a perpetual, exclusive (except as provided in Section 5.9(b)) right, privilege and easement along, over and across all portions of the Parcel B Easement Area, for the general use, convenience and benefit of StadCo, including without limitation all uses permitted under the Stadium Lease, without payment of any fee or other charge being made therefor.

(d) Declarant and StadCo shall have the right, at any time and from time to time, to exclude and restrain any person or entity from (i) exhibiting any placard, sign or notice, (ii) distributing any circular, handbill, placard or booklet, (iii) soliciting memberships, signatures or contributions for private, civic, public, charitable or political purposes, or (iv) parading, picketing or demonstrating in the Parcel B Easement Area.

(e) Except as set forth in this Declaration the easements granted in this Section 5.9 (the "StadCo Parcel B Easements") are for the sole and exclusive use of StadCo and its Benefited Parties, and shall not be construed in any manner to create or grant any rights to the public generally, to any other person or entity, or to any other Owner to use or enter upon the Parcel B Easement Area. Except as expressly set forth in this Declaration or in the Campus Use Agreement, StadCo shall not have the right to lease or otherwise permit the use of the Parcel B Easement Area by any other person or entity, nor assign any of the rights, privileges, duties or obligations of StadCo hereunder, without the prior written consent of Declarant; provided, StadCo shall have the right to assign its rights, privileges, duties and obligations hereunder in connection with a Permitted Assignment under the Stadium Lease to the same Person that is the permitted transferee pursuant to such Permitted Assignment.

(f) The term of the StadCo Parcel B Easements shall be coterminous with the StadCo Easement Term. Notwithstanding the expiration of the Stadium Lease term or the earlier termination of the easements described in, the respective rights and obligations of the Declarant and StadCo that are expressly intended to survive such expiration or earlier termination shall accordingly survive.

5.10 Plan of Easements. Notwithstanding anything to the contrary contained in this Declaration, before any Person commences construction of any new Improvement on Parcel C, Declarant, StadCo and all Parcel C Development Owners shall execute, deliver and record in the Register's Office of Davidson County, Tennessee a mutually acceptable addendum to this Declaration that sets forth the approved Plan of Easements.

5.11 Survival. For purposes of clarity, notwithstanding the expiration of the Stadium Lease term or the earlier termination of the StadCo Easement, the respective rights and obligations of the Declarant and the Parcel C Development Owners under this Declaration shall survive such expiration or earlier termination, for the entire Term.

5.12 Impacts from Use of Stadium. All Owners and their Benefited Parties acknowledge that the operation of the Stadium will produce light, noise, and/or odors in excess of levels typically occurring in mixed use developments, including, without limitation, light, noises and odors from events, aircraft flyovers, other special events and related activities. Discharge of firecrackers and other fireworks, lights and lasers may be utilized in connection with events, shows, and other special events; provided that such activities are conducted pursuant to the Requirements. Firework displays may include sudden noise, bright light, smoke and other events associated with the use of incendiary devices. Crowd noises, music, loudspeakers, horns, whistles, bells, and/or other sound devices may be audible to Owners in connection with the use of the Stadium.

5.13 Trash Storage. Trash, garbage and other waste and rubbish in the Plaza and other ingress-egress easement areas will be kept in sanitary containers provided specifically for these purposes and promptly and regularly removed. All equipment for the storage or disposal of such materials must be in accordance with all Governmental Requirements, Zoning Conditions and other applicable Requirements and must be kept in clean, sanitary and orderly condition. No burning of trash shall be permitted.

## **ARTICLE VI** **AMENDMENT**

This Declaration may only be amended by a written amendment that is executed by all Owners and the Declarant.

## **ARTICLE VII** **ENFORCEMENT**

7.1 Legal and Equitable Relief. If any Owner defaults in its obligations pursuant to this Declaration, and such default continues for more than thirty (30) days after written notice thereof from the Declarant or another Owner, then Declarant or such non-defaulting Owner shall have the right, but not the obligation: (i) to prosecute any proceedings at law or in equity against the defaulting Owner, or any other person, violating or attempting to violate or defaulting upon any of the provisions contained in this Declaration, in order to prevent the violating or defaulting Owner, or such other person, from violating or attempting to violate or defaulting upon the provisions of this Declaration, (ii) to recover damages for any such violation or default, and (iii) to obtain a temporary and/or permanent stay, injunction, restraining order, or other equitable relief to prevent the defaulting Owner, or other person, from any action in violation of this Declaration that could cause irreparable harm to the Project. Failure by Declarant or any Owner to enforce any covenant or restriction contained herein shall in no event be deemed a waiver of the right to do so thereafter. Notwithstanding anything in this Declaration to the contrary, neither Declarant nor any other Owner shall be liable under this Declaration for punitive, consequential or exemplary damages.

7.2 No Termination. A breach of this Declaration shall not entitle any Owner or person to cancel, rescind, or otherwise terminate its obligations hereunder.

## **ARTICLE VIII** **INDEMNIFICATION**

8.1 Indemnification. Each Owner other than and expressly excluding Metro, the Authority and any other Affiliate of Metro (an "Indemnifying Owner") shall save, indemnify and hold harmless the Declarant and the other Owners, including their council members, shareholders, members, managers, partners, directors, officers, employees and agents (collectively, "Indemnitees"), from and against any and all injury, loss, cost, damage, expense, action, threat, demand, suit, proceeding judgment, or liability of any nature whatsoever (including, but not limited to, liability for reasonable attorney's fees, fines, and penalties) (collectively, a "Claim") which may be claimed, asserted, or recovered against or from any Indemnatee arising from or out of and/or in any manner connected with any injury, loss, expense or damage to person or property arising out of any cause associated with the use of any portion of the StadCo Parcel B Easement Area or Parcel C by the Indemnifying Owner or the Controlled Owner Permittees of such Indemnifying Owner, except to the extent of the negligence or misconduct of the Indemnitees. Declarant hereby releases each Indemnifying Owner to the extent of all losses, out-of-pocket costs, fees, suits, damages, claims, obligations or liabilities, including, but not limited to, reasonable outside attorneys' fees, caused by activities undertaken by, for or on behalf of Declarant, the Authority and any other Affiliate of Metro; provided, however, that the foregoing release shall not apply with respect to any Claim for which such Indemnifying Owner is expressly obligated to indemnify the Declarant pursuant to Section 8.1.

## **ARTICLE IX** **INSURANCE AND CASUALTY LOSSES**

9.1 Individual Insurance. By virtue of taking title to (or an easement or a leasehold interest in) any portion of the Parcel B Easement Area or Parcel C subject to the terms of this Declaration, each Owner other than and expressly excluding Metro, the Authority and any other Affiliate of Metro covenants and agrees with all other Owners and with the Declarant that each Owner other than and expressly excluding Metro, the Authority and any other Affiliate of Metro shall obtain and maintain commercial general liability insurance with reasonable and prudent limits and terms (which may include, without limitation, deductibles and self-insurance pursuant to a bona fide plan of self-insurance) covering damage or injury occurring on its respective portion of Parcel C. StadCo agrees to maintain all-risk property insurance on the Plaza, excluding the Plaza Side-Line Area, and all structures and other Improvements constructed thereon, which shall cover loss or damage by fire and other hazards commonly insured under an all-risk policy, if reasonably available, and shall be in an amount sufficient to cover the full replacement cost of any repair or reconstruction in the event of damage or destruction from any such hazard. The policies required hereunder shall be in effect at all times.

### 9.2 Damage and Destruction -- Insured by Owners.

(a) The damage or destruction to all or any portion of any Improvement located on any portion of the Plaza shall be repaired or reconstructed promptly by the Owner thereof either, in such Owner's discretion (x) in a manner consistent with the original construction or (y) such other design or configuration as is approved in accordance with the Requirements. The Owner shall pay all costs which are not covered by insurance proceeds.

(b) The damage or destruction to all or any portion of any Improvement located on any portion of the Parcel C Development Area shall be repaired or reconstructed promptly by the Owner thereof as and to the extent required by the Ground Lease of the applicable portion of the Parcel C Development Area.

**ARTICLE XI**  
**MISCELLANEOUS**

10.1 Covenants Run with Land. All of the provisions, agreements, rights, powers, easements, covenants, restrictions, conditions and obligations contained in this Declaration shall run with the land and bind the land subject to this Declaration, and shall inure to the benefit of and be enforceable by the Declarant and the Owners, their respective successors and assigns during the Term, unless earlier expired or terminated as expressly provided herein. Without limiting the foregoing, it is expressly acknowledged that each covenant to do or refrain from doing some act on or with respect to Parcel B or Parcel C or portion thereof: (a) is a burden on the applicable portion of Parcel B or Parcel C and is for the benefit of each other applicable portion of Parcel C or Stadium Parcel, as applicable, and (b) shall be binding upon and inure to the benefit of all Owners and their respective heirs, successors and assigns.

10.2 Recordation. This Declaration shall become effective and binding upon the Declarant and its successors in interest upon recordation of this Declaration in the Register's Office of Davidson County, Tennessee.

10.3 Excusable Delays. Whenever performance is required of any Owner hereunder, that Owner shall use all due diligence to perform and take all necessary measures in good faith to perform; provided, however, that if completion of performance shall be delayed at any time by reason of any of the following ("Excusable Delays"): act of God (including, without limitation, delays from unusual or extreme weather events, flood, earthquake, tornado, fire, disease, and the like); labor strike or work stoppage or slowdown (including failure of building inspectors to reasonably process approvals that cause work stoppage); failure or delay by in receipt of any approval of Governmental Requirements (including, without limitation, any failure to complete rezoning or delay in completion of the rezoning; any delays or shortages encountered in transportation, fuel, material or labor supplies; any failure of or delay in the availability of any public utility; material shortages in supplies; sabotage, acts of a public enemy, war, riot, terrorism, moratorium, or actual or threatened health emergencies (including, without limitation, epidemic, pandemic, quarantines or other restrictions related thereto); and governmental embargo restrictions, injunctions, or delay in any inspection by any governmental authority (financial inability, imprudent management or negligence excepted), then the time for performance as herein specified shall be appropriately extended by the amount of the delay actually so caused.

10.4 Validity and Severability. Violation of or failure to comply with the provisions of this Declaration shall not affect the validity of any Mortgage, bona fide lien or other similar security instrument which may then be existing as an encumbrance on any Parcel therein. Invalidation of any one or more of the provisions of this Declaration, or any portions thereof, by a judgment or court order shall not affect any of the other provisions herein contained, which shall remain in full force and effect, unless enforcement of this Declaration as so invalidated would be unreasonable or grossly inequitable under all the circumstances or would frustrate the purposes of this Declaration.

10.5 Notice. All notices, demands, submissions, requests, consents, approvals and other instruments required or permitted to be given pursuant to the terms hereof, shall be in writing and shall be deemed to have been properly given if (i) delivered by hand, (ii) or sent by registered or certified United States mail, postage prepaid, return receipt requested, or (iii) by nationally recognized overnight mail or courier service:

To Developer TFC Nashville Development LLC  
c/o The Fallon Company LLC  
1222 Demonbreun Street  
Nashville, TN 37203  
Attn: Ben Farrer

and TFC Nashville Development LLC  
c/o The Fallon Company LLC  
One Marina Park Drive  
Boston, MA 02210  
Attn: Brian Awe

with a copy to: Bradley, Arant, Boult Cummings, LLP  
One 22 One  
1221 Broadway, Suite 2400  
Nashville Tennessee 37203  
Attn: J. Thomas Trent

To Declarant: Nashville City Hall, Suite 100  
1 Public Square  
Nashville, Tennessee 37201  
Attn: Mayor

with a copy to: Metropolitan Department of Law  
1 Public Square, Suite 108  
Nashville, Tennessee 37201  
Attn: Director of Law

Greenberg Traurig, LLP  
1000 Louisiana Street, Suite 6700  
Houston, Texas 77002  
Attn: Denis C. Braham

To StadCo: Tennessee Stadium, LLC  
St. Thomas Sports Park  
460 Great Circle Road  
Nashville Tennessee 37228  
Attn: President/CEO

with a copy to: Tennessee Stadium, LLC  
St. Thomas Sports Park  
460 Great Circle Road  
Nashville Tennessee 37228



Attn: Chief Operating Officer

with a copy to:

DLA Piper LLP (US)  
One Fountain Square  
1911 Freedom Drive, Suite 300  
Reston, Virginia 20190  
Attn: Mark D. Whitaker

or to such other addresses as may from time to time be specified in writing by the above referenced persons. Any notices or other communications under this Declaration must be in writing and shall be deemed duly given or made at the time and on the date when personally delivered as shown on a receipt therefor (which shall include delivery by a nationally recognized overnight delivery service) to the address for each person set forth above and for which a statement has been filed of record as provided below or when delivery is refused. Any such person, by written notice to the others in the manner herein above provided, may designate an address different from that set forth below. Any notice to be given by any person pursuant hereto may be given by the counsel for such person. Upon the execution of a Ground Lease of the Parcel C Development Area, the Owner (as the Ground Lessee of such portion of Parcel C) shall file of record in the Register's Office of Davidson County, Tennessee, a statement that contains the name of such Owner and the address to whom all notices for the purposes of this Declaration shall be sent and the date that such interest was acquired, and shall provide a copy thereof by notice by hand delivery, certified mail or courier service pursuant to this Section to Declarant, StadCo and the other Owners for which such a statement has previously been filed of record, provided however that the failure to file such a notice of record shall not affect the rights and obligations of such new Owner hereunder.

10.6 Liability Upon Transfer. Each Person's liability and obligations hereunder shall terminate upon the conveyance by an Owner of its ownership interest in Parcel B or Parcel C (or portion thereof), as applicable, with respect to the portion of Parcel B or Parcel C so conveyed only with respect to liabilities or obligations accruing anytime other than during the period of such Owner's ownership.

10.7 Prior Agreements. Any prior correspondence, memoranda or oral agreements with respect to the subject matter hereof are superseded in total by this Declaration and the Exhibits hereto. The provisions of this Declaration and the Exhibits attached hereto shall be construed as a whole according to their common meaning and not strictly for or against any party.

10.8 Litigation Expenses. If Declarant or any Owner brings an action against any other Owner by reason of the breach or alleged violation of any covenant, term or obligation hereof, or for the enforcement of any provision hereof or otherwise arising out of this Declaration, the prevailing party in such suit shall be entitled to its costs of suit and reasonable attorneys' fees from the non-prevailing party (excluding Metro and any of its Affiliates, it being understood that Metro and its Affiliates shall not be liable or responsible for the attorney's fees or costs of suit of any other party pursuant to this Section 10.8).

10.9 Governing Law; Place of Performance. This Declaration and all rights and obligations created hereby shall be governed by the laws of the State of Tennessee. This Declaration is performable only in Davidson County, Tennessee.

10.10 Non-Merger. The ownership or leasing, at any time during the term of this Declaration, of more than one Parcel by the same Owner or Declarant shall not create a merger of title or estate, or other merger, including any merger of the dominant and servient estate with respect to easements granted in this Declaration, and shall therefore not terminate any of the easements, restrictive covenants, or other terms or provisions of this Declaration.

10.11 Time. Subject to Section 10.3 time is of the essence of this Declaration and each and every provision hereof.

10.12 Estoppel Certificate. Any Owner may, at any time, deliver written notice to the other Owner(s) and/or the Declarant requesting such Owner(s) and/or the Declarant to certify in writing: (a) that to the best knowledge of the certifying Owner(s) and/or the Declarant, the requesting Owner is not in default in the performance of its obligations under this Declaration, or, if in default, to describe therein the nature and amount of any and all defaults, and (b) to such other reasonable factual matters as the requesting Owner may request. Each Owner and/or Declarant, as applicable, receiving such a request shall execute and return such certificate within twenty (20) days following the receipt thereof. If an Owner and/or Declarant fails to respond then the requesting Owner may notify that Owner and/or Declarant, as applicable, in a second request which must be sent in an envelope marked "SECOND REQUEST -- IMMEDIATE RESPONSE REQUIRED." If the Owner or the Declarant, as applicable, fails to execute and return such certificate within ten (10) days after receipt thereof, then that Owner's or the Declarant's silence shall be deemed an admission on such Owner's or the Declarant's part, as applicable, that the Owner requesting the certificate is current and not in default in the performance of such Owner's obligations under this Declaration, and otherwise a favorable response. The parties acknowledge that such certificate may be relied upon by purchasers, tenants, transferees, Mortgagees and leaseback-lessors.

10.13 Rules of Construction. The terms "herein," "hereof," "hereunder," "hereby," "this Declaration" and other similar references shall be construed to mean and include this Declaration and all amendments thereof and supplements thereto unless the context clearly indicates or requires otherwise. The captions of each Section hereof as to the contents of each Section are inserted only for convenience and are in no way to be construed as defining, limiting, extending or otherwise modifying or adding to the particular Section to which they refer. All references to "Sections" contained in this Declaration are, unless specifically indicated otherwise, references to articles, sections, subsections, and paragraphs of this Declaration. Whenever in this Declaration the singular number is used, the same shall include the plural where appropriate (and vice versa), and words of any gender shall include each other gender where appropriate. As used in this Declaration, the following words or phrases shall have the meanings indicated: (i) "day" shall mean a calendar day; (ii) "including" or "include" shall mean "including without limitation"; (iii) "law" or "laws" shall mean statutes, regulations, rules, judicial orders, and other legal pronouncements having the effect of law; and (iv) "persons" shall mean any individual, corporation, partnership, limited liability company, government or other entity. All references to "Exhibit(s)" and "Schedule(s)" are, unless specifically indicated otherwise, references to exhibits, schedules, and attachments to this Declaration, which are incorporated into this Declaration by each such reference. Whenever there is imposed on any party an obligation to use best efforts, commercially reasonable diligence, or reasonable efforts or diligence, such party will be required to exert those efforts or diligence only to the extent they are economically feasible, practicable, and reasonable under the circumstances and will not impose upon such party extraordinary financial or other burdens. As used herein, "good faith" means honesty in fact and in accordance with reasonable commercial standards of fair dealing in the commercial real estate industry.

10.14 Regarding Declarant. Metro may assign its rights and obligations as the Declarant under this Declaration to its successor(s) in title as fee owner of the Parcel C Development Area. Notwithstanding any other provision contained in this Declaration to the contrary, upon no less than 30 days' written notice to the Owners, Declarant may assign its rights and obligations under this Declaration, in whole or in part, to an authority or instrumentality (each, an "Authority") of Metro which has been formed for the specific purpose of owning and/or administering the Project on behalf of Metro, including without limitation in connection with a transfer of title to such Authority. Declarant shall endeavor to deliver written notice of any such assignment to the Owners. From and after any such assignment, Metro shall be relieved of any obligations first arising after such assignment.

10.15 Approval by Declarant. Any consent or approval of Declarant required under this Declaration shall be: (i) in writing, and (ii) executed by a duly authorized representative of Declarant.

10.16 Conflicting Agreements.

(a) In the event of any conflict between the terms and conditions of this Declaration and any other Requirements as to the terms and conditions of the easements created by this Declaration, the terms and conditions of this Declaration shall control and be enforceable as to such easements.

(b) In the event of any other conflict between the terms and conditions of this Declaration and a Ground Lease, the terms and conditions of the applicable Ground Lease shall control and be enforceable.

(c) In the event of any other conflict between the terms and conditions of this Declaration and the Campus Use Agreement, the terms and conditions of the Campus Use Agreement shall control and be enforceable.

10.17 Effect of Breach on Mortgagee and Right to Cure. Any Mortgage affecting any portion of Parcel C shall at all times be subject and subordinate to the terms of this Declaration, and any party foreclosing any such Mortgage or acquiring title by deed in lieu of foreclosure (whether judicial or non-judicial) or trustee's or receiver's sale shall acquire title subject to all of the terms and provisions of this Declaration.

(a) Breach of any of the covenants or restrictions contained in this Declaration shall not defeat or render invalid the lien of any Mortgage made in good faith, but all of the foregoing provisions, restrictions, and covenants shall be binding and effective against any Owner who acquires title by foreclosure (whether judicial or non-judicial) or trustee's or receiver's sale or by deed in lieu of foreclosure.

(b) Notwithstanding any other provision in this Declaration for notices of default, the Mortgagee of record of any Owner in default hereunder shall be entitled to notice of said default simultaneously with notice to such defaulting Owner, in the same manner that other notices are required to be given under this Declaration; provided, however, that said Mortgagee shall have, prior to the time of the default, expressly notified in writing, the other Owner giving said notice of default of the Mortgagee's mailing address. In the event that any such notice shall be given to such Mortgagee, such Mortgagee shall have the right to cure any such default within the cure period expressly provided to the defaulting Owner hereunder, or, if such default cannot be cured within such period, diligently to commence curing within such time and diligently pursue such cure to completion within sixty (60) days thereafter. Giving of any notice of default to any Mortgagee shall in no event create any liability on the part of the Owner so declaring a default, but the failure to give any such notice to which a Mortgagee is entitled shall have the effect of tolling the commencement of the cure period to which such Mortgagee is entitled until such notice is delivered.

[SIGNATURE PAGE TO FOLLOW.]

EXECUTED by the undersigned to be effective for all purposes as of the date first above written.

**[ADD SIGNATURE BLOCK / NOTICE ADDRESS / NOTARY]**

## APPENDIX

Activation. Subject to any applicable Requirements, means the use of the Plaza for the following: the sale of goods and services; the sale of food and beverage; sponsorship, marketing, advertising, merchandising, product placement and promotional activities; performance of athletic activities; and education, entertainment and the performing and visual arts, including without limitation live musical acts.

Affiliate. Any corporation, partnership, limited liability company, sole proprietorship or other individual or entity that directly or indirectly, through one or more intermediaries controls, is controlled by or is under common control with the individual or entity specified. The terms “control”, “controlled by”, or “under common control” mean the possession, direct or indirect, of the power to direct or cause the direction of the management and policies of an individual or entity.

Authority. Defined in Section 10.14.

Benefited Parties. As to any Owner other than the tenant under the Stadium Lease, such Owner’s tenants, subtenants, agents, licensees, customers, invitees (including without limitation concessionaires and contractors), and employees. As to the tenant under the Stadium Lease, its Affiliates and such tenant’s and such Affiliates’ tenants, subtenants, agents, licensees, customers, invitees (including without limitation concessionaires and contractors), and employees.

Campus Use Agreement. That certain Campus Operations and Use Agreement among, Metro, StadCo and Developer dated \_\_\_\_\_, 2024, as modified, amended, extended or replaced.

Community Purpose. Defined in Section 3.1(d) of this Declaration.

Controlled Owner Permittees. Means, as to any Indemnifying Owner, any Owner Permittee who (i) is an Affiliate of such Indemnifying Owner, (ii) is employed by such Indemnifying Owner or any Affiliate of such Indemnifying Owner, (iii) has a contractual relationship with such Indemnifying Owner or any Affiliate of such Indemnifying Owner relating to such Indemnifying Owner’s use of Parcel B or Parcel C, as applicable, or (iv) is otherwise controlled, directly or indirectly, by such Indemnifying Owner or any Affiliate thereof; provided, however, that, without limitation, and except as provided above, (i) holders of admission tickets and other patrons or attendees at Stadium events or Plaza events shall be presumed to be not under the control of any Indemnifying Owner or any Affiliate thereof absent clear and convincing evidence to the contrary (and an Indemnifying Owner’s right to eject any such ticketholder or other patron or to revoke any current or future admission ticket of such ticketholder or other patron from the Stadium or Plaza, including any season or subscription tickets, shall not be sufficient evidence of control by such Indemnifying Owner or any Affiliate of such Indemnifying Owner), and (ii) residents, occupants and their invitees in any building located on the Entire Tract and any employees, customers or invitees of any business located on the Entire Tract shall be presumed to be not under the control of any Indemnifying Owner or any Affiliate thereof absent clear and convincing evidence to the contrary. For purposes of Article VIII, a Controlled Owner Permittee of one Owner shall not be deemed a Controlled Owner Permittee of another Owner merely because a contractual relationship between such Owners exists; provided, however, that this shall not abrogate any indemnity claim against an Owner pursuant to Article VIII based on the act or omission of such Owner’s own Controlled Owner Permittee.

Cumberland Walk. Means that portion of Parcel C more particularly described on Exhibit B-5 attached hereto and incorporated herein by reference, such location to be subject to adjustment in the Plan of Easements.

Declarant. Means the signatory to this Declaration named on the signature page hereto, its successors and assigns.

Dedicated Right of Way. Any portions of the Entire Tract now or hereafter owned by or dedicated to Metro for use as public streets or pedestrian walkways.

Developer. The TFC Nashville Development, LLC, together with its Affiliates, successors and assigns.

Development-Wide Standard. Means standards of quality with respect to the construction, maintenance and operation of the Project that are at least equivalent to the standards of quality with respect to the aesthetics, maintenance, and operation existing in and maintained at first-class mixed use developments located within the Nashville, Tennessee metropolitan area. Such standard may be more specifically determined by the Declarant, but must be consistent with the Development-Wide Standard originally established by the Declarant, which, for avoidance of doubt, is the standard established by the first sentence of this definition and shall require that the Project be maintained in a first-class condition taking into account its location and age, in good order, condition and repair, in compliance with all applicable laws, and in a neat, clean, safe and attractive condition, comparable to other first-class sports and entertainment facility anchored mixed use developments of comparable age, adjusted to reflect any material renovations that would typically be made for a project of similar age located within the Nashville, Tennessee metropolitan area. Notwithstanding the foregoing, for so long as the Stadium remains in operation as a stadium venue, the Development-Wide Standard may be designated by Declarant from time to time in its discretion based on other comparable national/international stadium-anchored mixed-use developments of comparable period of original construction.

Excusable Delays. Has the meaning set forth in Section 10.3 of this Declaration.

Entire Tract. Means the real property more particularly described on Exhibit B-6 attached hereto and incorporated by reference herein.<sup>1</sup>

Exceptions. Means, collectively, any and all existing easements, covenants, rights-of-way, conditions, restrictions, outstanding mineral interests and royalty interests, if any, relating to Parcel C or any applicable portion thereof, to the extent the same may still be in force and effect, and either shown of record in the office of the Real Property Records of Davidson County, or that may be apparent on Parcel B or Parcel C, as applicable, or applicable portion thereof.

Governmental Requirements. Means any applicable laws, rules, regulations or requirements of any governmental or quasi-governmental agency or authority, including without limitation Metro.

Ground Lease(s). Any ground lease(s) of the Parcel C Development Area from Metro or the then current Owner thereof to a Ground Lessee entered into from time to time, as amended, individually or collectively as the context may require.

Ground Lessee(s). The ground lessee(s) under any Ground Lease(s), individually or collectively as the context may require.

Hazardous Materials. Means any pollutant, toxic substance, hazardous waste, hazardous material, hazardous substance, petroleum, oil, or any petroleum by-product defined as a hazardous substance under

---

<sup>1</sup> Confirm the area the “Entire Tract” covers.

any applicable federal, state, or local laws, regulations or ordinances whether existing as of the date this Declaration is recorded in the Register's Office of Davidson County, Tennessee, or subsequently enacted.

Improvements. Means any building, structure, parking areas, driveways, curbs, sidewalks, pavement, signage, landscaping and other improvements, now or hereafter located within the Project.

Master Development Agreement. That certain Development Agreement between Metro and the Developer dated \_\_\_\_\_, 2024, as modified, amended, extended or replaced.

Metro Plaza Events. Has the meaning assigned by the Campus Use Agreement.

Mortgage. Means any and all instruments used for the purpose of encumbering real property in the Project (or any leasehold estate therein) as security for the payment or satisfaction of an obligation, including, without limitation, any mortgage or deed of trust.

Mortgagee. Means the holder of or beneficiary under a Mortgage.

Neighboring Areas. Has the meaning set forth in Section 5.8 of this Declaration.

Outdoor Seating Purpose. Has the meaning set forth in Section 3.1 of this Declaration.

Owner. Means Declarant and its successor(s)-in-title to any portion of Parcel B or Parcel C. With respect to the Parcel C Development Area that is subject to a Ground Lease, "Owner" shall mean only the Ground Lessee of such Parcel or its written designee. With respect to the Plaza that is subject to the StadCo Easement, "Owner" shall mean only StadCo during the term of the Stadium Lease. The term "Owner" does not include any Mortgagee or trustee who may hold a lien against any portion of Parcel C or leasehold interest under a ground lease or easement pursuant to a Mortgage unless and until such Mortgagee shall acquire record fee simple title or record leasehold or easement title to any such tract through foreclosure, deed in lieu of foreclosure, or otherwise. A reference to "Owners" shall mean all Owners.

Owner Permittee. Means, as to any Indemnifying Owner, all direct and indirect tenants and subtenants of such Indemnifying Owner and the officers, directors, employees, agents, representatives, contractors, customers, vendors, suppliers, visitors, invitees, guests, licensees and concessionaires of such Indemnifying Owner and such tenants and subtenants thereof. No other Owner or such other Owner's Indemnitees shall constitute an Owner Permittee as to any such Indemnifying Owner hereunder. Persons engaged in civic, public or political activities, including, but not limited to, the activities set forth below, unless such Persons have been authorized to do so by the Indemnifying Owner, shall not be considered Owner Permittees of such Indemnifying Owner:

- (a) Exhibiting any placard, sign or notice;
- (b) Distributing any circular, handbill, placard or booklet;
- (c) Soliciting memberships or contributions for private, civic, public or charitable purposes;
- (d) Parading, picketing or demonstrating; and
- (e) Persons engaged in civic, public or political activities within Parcel C.

Parcel(s). Parcel B and Parcel C, as shown on the Site Plan, individually or collectively as the context may require.

Parcel B Easement Area. The land described and depicted on the Parcel B Site Plan as the “Parcel B Easement Area”.

Parcel C Development Owner(s). Singularly an Owner and plurally more than one Owner of the Parcel C Development Area from time to time.

Permitted Assignment. Has the meaning set forth in the Stadium Lease.

Permitted Uses. Any uses on the Plaza permitted by the applicable Zoning Conditions but subject to this Declaration and the other Requirements.

Persons. Means any individual, corporation, partnership, joint venture, association, joint stock company, trust, limited liability company, unincorporated organization, governmental authority or any other form of entity.

Plan of Easements. Means a site plan and/or legal descriptions approved in writing by Declarant, Parcel C Development Owner(s), and StadCo that include metes and bounds legal descriptions of the StadCo Easement area and the other easements created pursuant to this Declaration.

Plat. Means all plat(s) depicting Parcel C, or any portion thereof, now or, subject to the approval of all Owners (such approval not to be unreasonably withheld, conditioned or delayed), hereafter recorded in the Register’s Office of Davidson County, Nashville, Tennessee.

Plaza. Has the meaning set forth in Recital C of the preamble of this Declaration.

Plaza Improvements. Means those capital improvements required to be made by StadCo to the Plaza in accordance with the terms of the Stadium Development Agreement, pursuant to plans that shall be subject to the prior written approval of Developer, which shall not be unreasonably withheld, provided that the only basis upon which it shall be deemed reasonable for Developer to withhold approval is that such improvements materially adversely impact Developer’s ability to develop Parcel C.

Plaza Land. Has the meaning set forth in Recital D of the preamble of this Declaration.

Plaza Property. Has the meaning set forth in Recital D of the preamble of this Declaration.

Plaza Side-Line Area. Has the meaning set forth in Section 3.1 of this Declaration.

Private Requirements. Any easements, covenants, and restrictions affecting Parcel B or Parcel C, as applicable, that are of record on the date hereof in the Davidson County Register’s Office.

Prohibited Uses. Uses of any portion of Parcel C that are expressly prohibited, as more particularly set forth on Exhibit D attached hereto and incorporated by reference herein.

Project. Means the Entire Tract together with all Improvements thereon.

Public Use Easement. A non-exclusive easement reserved by Metro upon, through, over and across the Plaza for Public Use Events.

Public Use Events. Metro Plaza Events and Separate Events to be held at the Plaza designated and scheduled by Metro in accordance with the Campus Use Agreement.



Requirements. The terms, conditions, obligations and requirements of (i) the applicable Zoning Conditions and other Governmental Requirements and (ii) the Private Requirements.

Separate Events. Has the meaning assigned by the Campus Use Agreement.

Site Plan. Defined in Recital A of this Declaration.

Sports Authority. The Sports Authority of the Metropolitan Government of Nashville and Davidson County.

StadCo. Tennessee Stadium, LLC, and its permitted successors and assigns.

StadCo Easement. Defined in Section 3.1 of this Declaration.

StadCo Easement Term. Defined in Section 3.3 of this Declaration.

StadCo Parcel B Easements. Defined in Section 5.9(b) of this Declaration.

Stadium. The stadium venue to be constructed and operated adjacent to Parcel C, as more particularly shown on the Site Plan.

Stadium Development Agreement. That certain Development and Funding Agreement between StadCo and the Sports Authority dated August 25, 2023, as modified, amended, extended or replaced.

Stadium Lease. That certain Stadium Lease Agreement between StadCo and the Sports Authority dated as of August 25, 2023, as modified, amended, extended or replaced.

Stadium Parcel. Has the meaning set forth in Recital B.

Stadium Platform. The area adjacent to the southerly side of the Stadium, as more particularly shown on the Site Plan.

Temporary Easement. Has the meaning set forth in Section 5.8 of this Declaration.

Temporary Easement Area. Has the meaning set forth in Section 5.8 of this Declaration.

Term. Except as otherwise expressly set forth herein, this Declaration shall remain in effect until the earlier of (i) the recording of a termination of this Declaration in the Register's Office of Davidson County, Tennessee, executed by Declarant and all the other Owners; or (ii) the later of (x) the expiration or earlier termination of all the Ground Leases, (y) the Fiftieth (50th) anniversary of the date of this Declaration, or (z) the expiration or earlier termination of the Stadium Lease; provided, that the Term shall automatically renew for additional successive ten (10) year periods unless Declarant and all Owners execute a termination of this Declaration as provided in (i) above.

Use Guidelines. The use guidelines applicable to the Plaza promulgated and administered by the Campus Coordination Committee under the Campus Use Agreement from time to time.

Utilities. Means utilities now or hereafter servicing the Project and the facilities for such utilities (including, but not limited to, electric power, telephone, cable, water, sewer, storm drains and drainage and natural gas).

Utilities Easements. Means (A) perpetual nonexclusive easements for the benefit of each Parcel on, across and under any Dedicated Right of Way to install, use, maintain and repair public Utilities services and distribution systems (including storm drains, sewers, Utilities and other proper services necessary for the orderly development and use of each Parcel), now upon or hereafter installed on, across or under any Dedicated Right of Way to the extent necessary to service such Parcel; and (B) any other Utilities easement areas on a Parcel indicated on the Plat.

Zoning Conditions. Any development order, zoning category, or zoning condition related or applicable to all or any portion of The East Bank Nashville and any other governmental or quasi-governmental order, permit, or approval applicable to Parcel C.

Exhibit A-1.A

Parcel B Site Plan

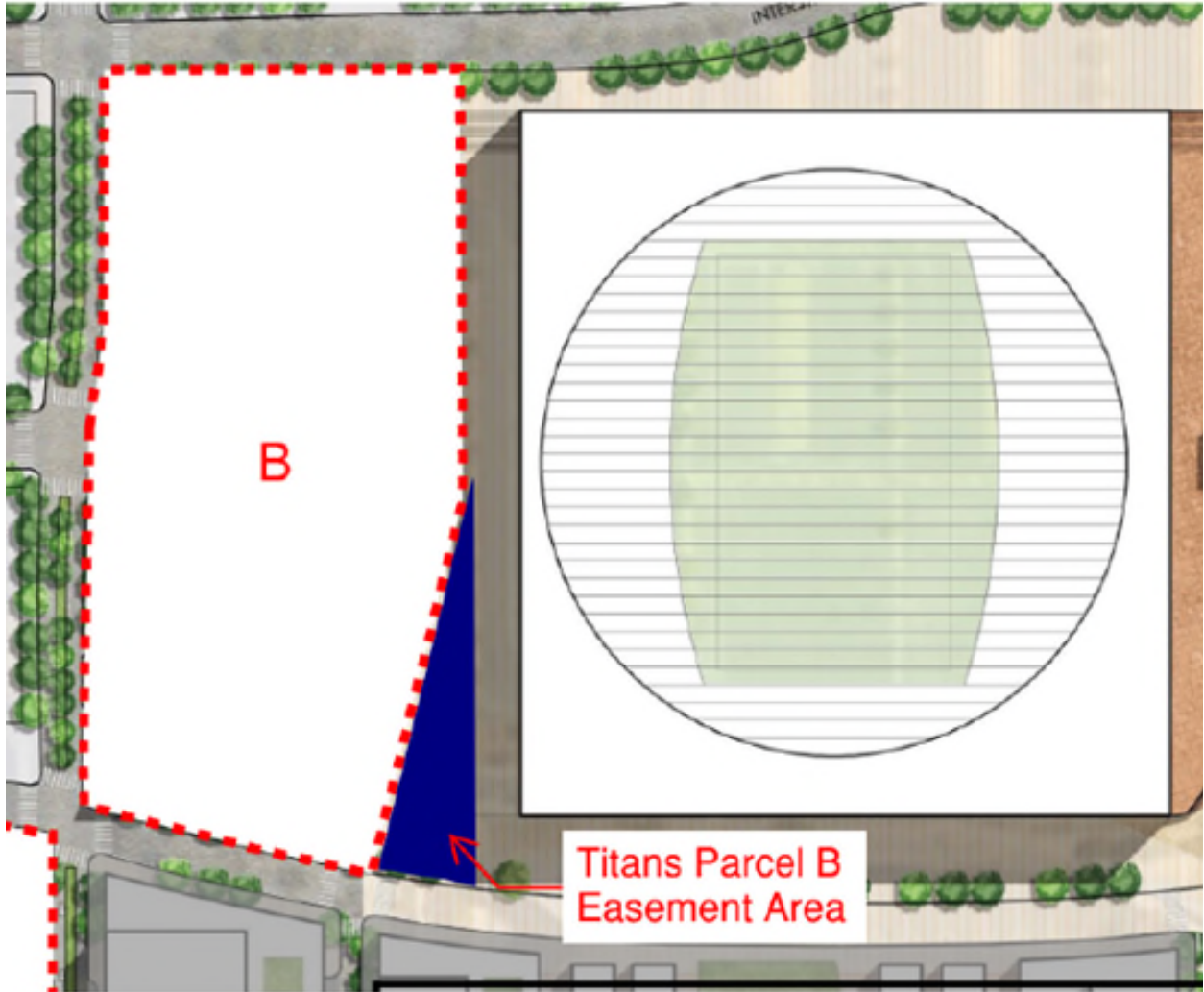

Exhibit A-1.B

Parcel C Site Plan

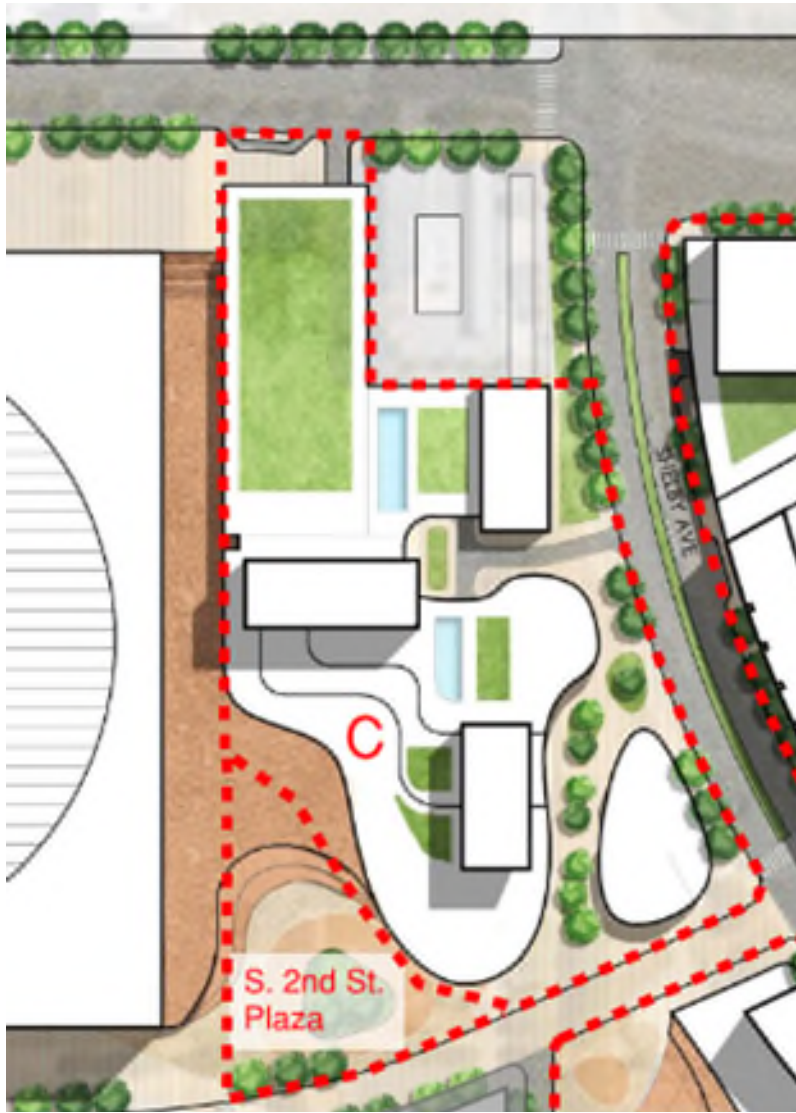

Exhibit B-1.A

Legal Description of Parcel B

(to be provided upon completion of survey)

Exhibit B-1.B

Legal Description of Parcel C

(to be provided upon completion of survey)

Exhibit B-2

Stadium Parcel

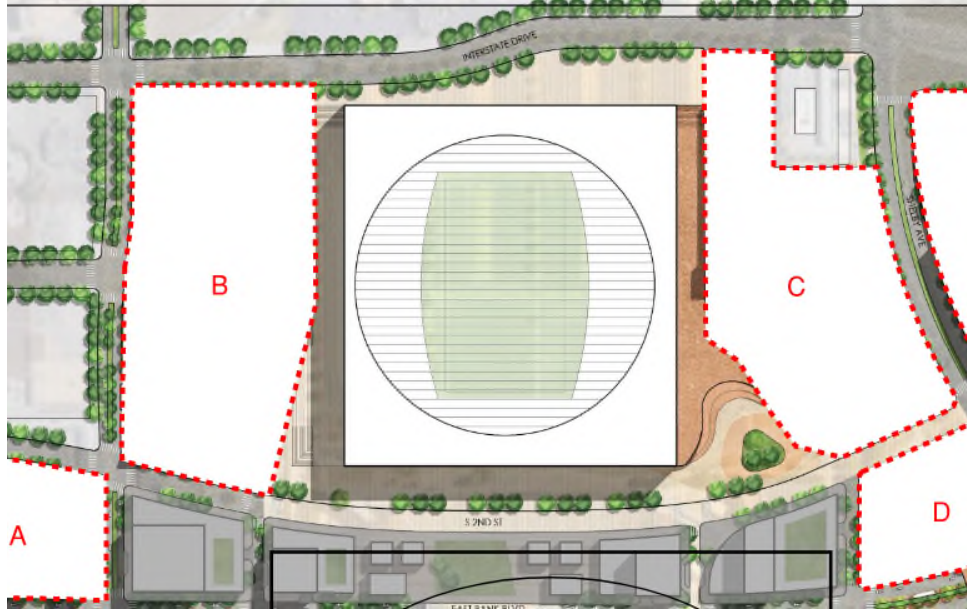

Exhibit B-3

Parcel C Development Area

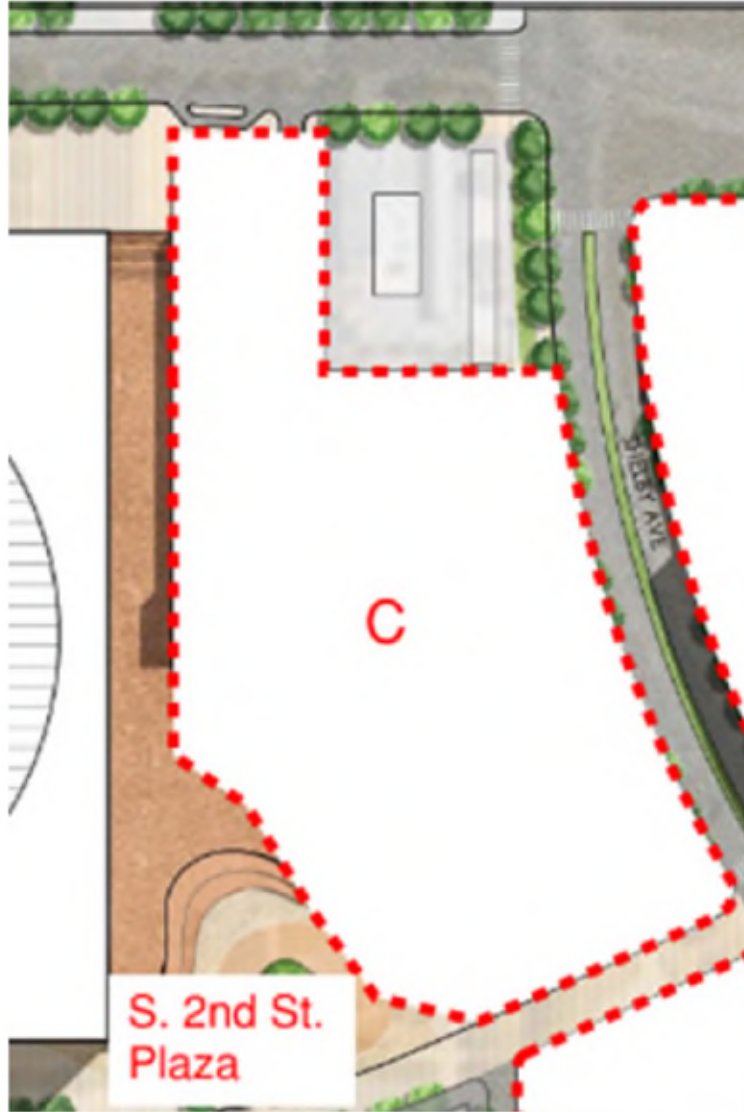



Exhibit B-4

Plaza Land

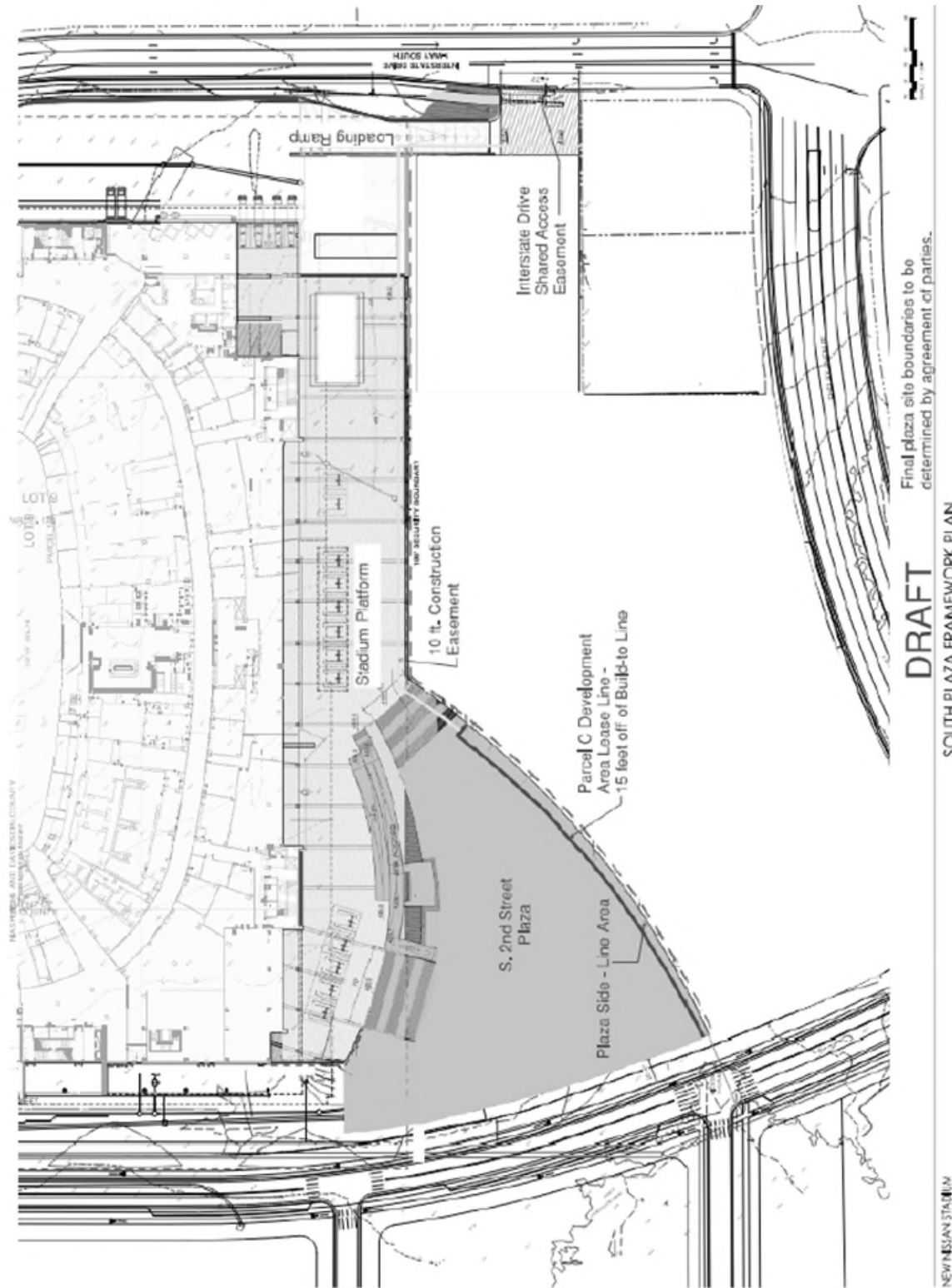

Exhibit B-5

Description of Cumberland Walk



Exhibit B-6

Entire Tract



Exhibit B-7

Temporary Easement Area

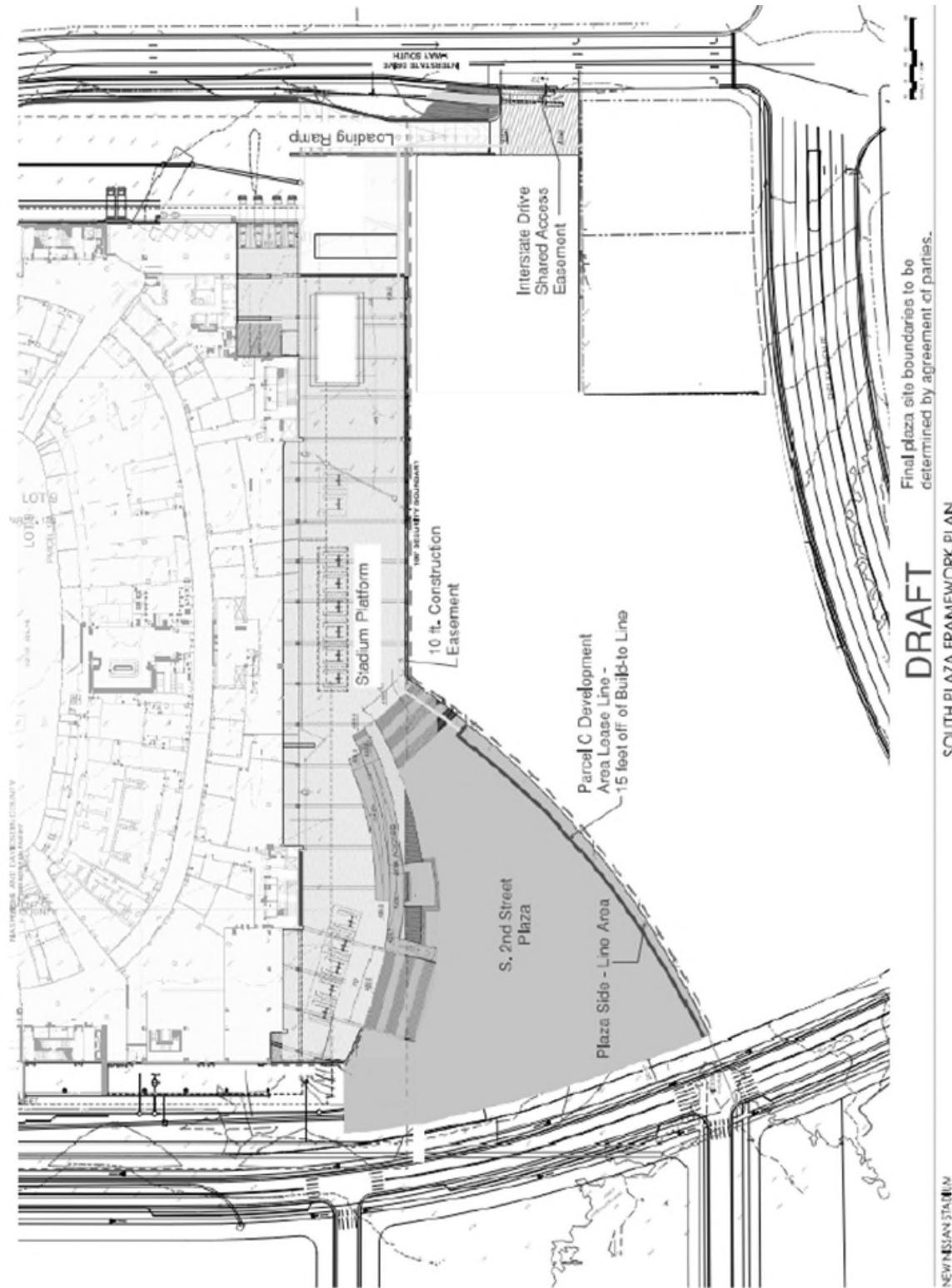
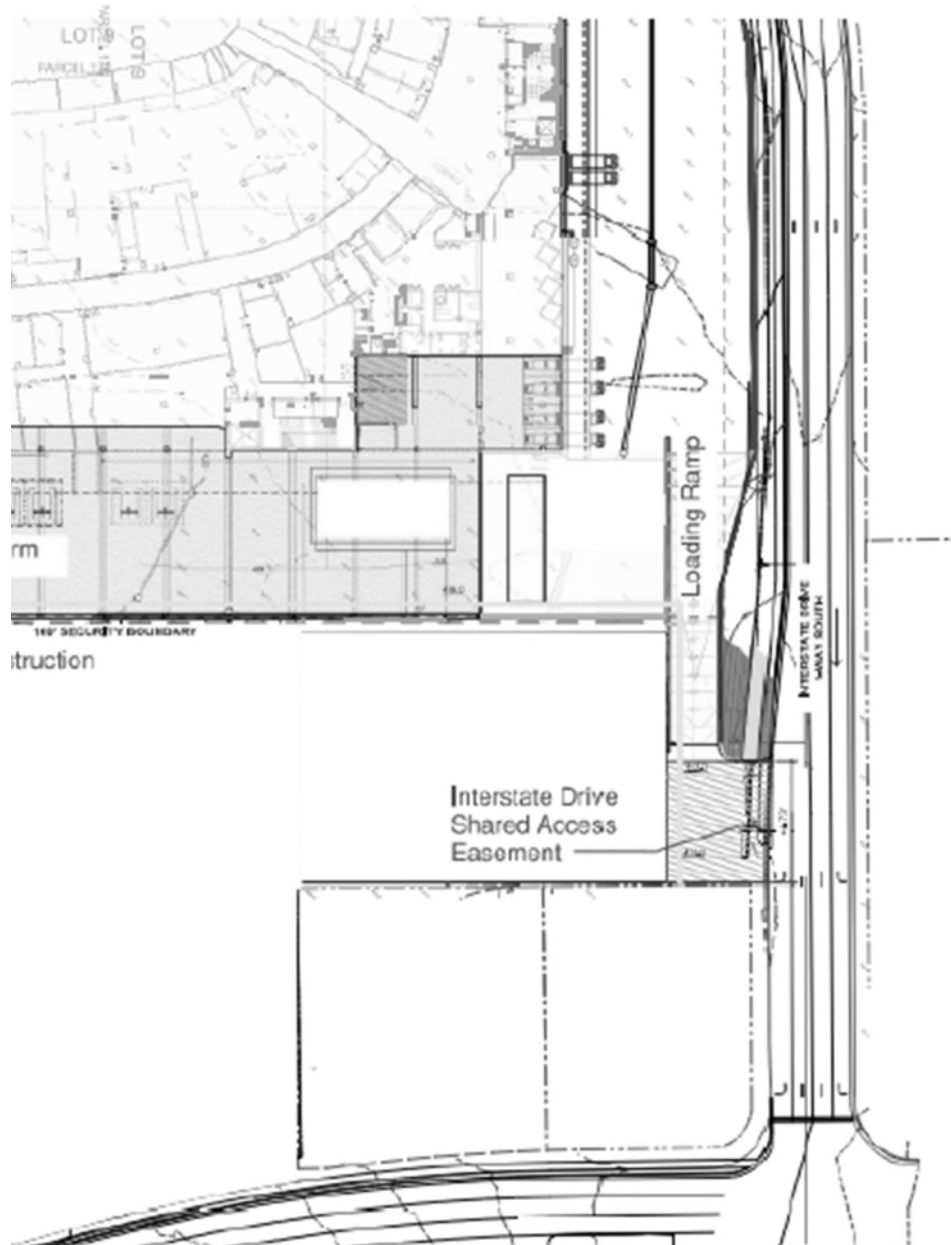

Exhibit C

Loading Ramp



## Exhibit D

### Prohibited Uses

Prohibited Uses. All of the following items or uses are prohibited on the Plaza:

- (1) Carwash.
- (2) Cemetery, mausoleum, columbarium, funeral parlor, mortuary, undertaking, or similar.
- (3) Commercial laundry, laundromat, or dry cleaning plant (excluding any laundry services provided by a hotel or apartment building or otherwise incidental to a use not prohibited hereunder).
- (4) An Adult Oriented Establishment, defined below. As used herein, an “Adult Oriented Establishment” means any business, establishment, building or place in which any of the owner(s), operator(s), customer(s), invitee(s) or other occupant(s) is engaged in any Adult Oriented Activity. As used herein, an “Adult Oriented Activity” means any of the following: (i) the exhibition or presentation of any x-rated motion picture, recorded or live performance, display or dance of any type, that has as a principal or predominant theme, emphasis, or portion of such performance, any actual or simulated performance of sexual intercourse or other sexual activities; (ii) the removal of articles of clothing and/or the exhibition or the exposing to the public view of patrons, at any time, of Specified Anatomical Areas; (iii) the sale or other trade in material, devices, or paraphernalia, or any combination or form thereof, having as a dominant theme an emphasis on matter depicting, describing or relating to sexual intercourse or other sexual activities, whether printed, filmed, or otherwise recorded or presented, regardless of how labeled or sold or characterized, including, but not limited to, adult books, films, novelties, risqué gifts or marital aids; and (iv) the sale or other trade in sexual activities of any kind, irrespective of their legality, including, without limitation, any activities of the type that are reportedly conducted in connection with any escort agency or service, sexual encounter center or studio, adult massage parlor, exotic dance studio, or any other term of like import. As used herein, “Specified Anatomical Areas” includes, but is not limited to, the bare female breast below a point immediately above the top of the areola, human genitals, pubic region, or buttocks. For purposes of clarity, the foregoing shall not in any way limit or restrict the presentation of motion pictures that are R-rated, even if such motion pictures depict Specified Anatomical Areas.
- (5) Game preserve, wildlife management area, refuge, or animal sanctuary.
- (6) Mining and mineral extraction.
- (7) Mobile home or manufactured home park.
- (8) Payday loans and vehicle title loan establishments.
- (9) Tattoo Parlor.
- (10) Industrial services (including detention center, jail, or prison; lumberyard or wood products; research, testing, and development laboratory; sheet metal shop; soft drink bottling; welding, machine, tool repair shop; woodworking, cabinet making, and furniture

manufacturing; asbestos products; chemical, cosmetics, drug, soap, paints, fertilizers, and abrasive products manufacturing; explosives; petroleum, liquefied petroleum gas, and coal products manufacturing, including refining; radioactive materials/waste; and rubber and plastic products manufacturing). Notwithstanding the foregoing, Declarant may in its reasonable discretion grant limited exceptions from the foregoing prohibition for so-called "maker spaces."

- (11) Self-storage facilities except incidental to uses not prohibited hereunder.
- (12) Storage, warehouse and distribution (excluding any storage and warehousing incidental to the operation of uses not prohibited hereunder).
- (13) Used goods, thrift shops, second hand sales, including pawn shops.
- (14) Vehicle or vehicular body shop, rentals, service, or repair except incidental to uses not prohibited hereunder.
- (15) Vehicle service, fueling station, or gas station except incidental to uses not prohibited hereunder, and except that vehicle charging station(s) are permitted.
- (16) Waste related services, including junkyard, recycling center or recycling collection station (excluding any recycling or waste disposal incident to the operation of uses not prohibited hereunder or otherwise related to hotel, retail, or office operations), and solid waste facility.
- (17) Gambling, lotteries, sports book business(es) and other games of chance, including without limitation slot machines and similar gambling devices.
- (18) Short term rentals (such as, by way of example only, Air BnB and VRBO) of any non-hotel multifamily or other residential property within Parcel C.
- (19) The sale, display, cultivation, development, distribution, and/or administration of narcotics or any other controlled substances not part of a doctor's office or laboratory, or full-service pharmacy, including any methadone clinic.
- (20) Any Prohibited Uses, as defined in Exhibit E of the Stadium Lease other than as set forth in subsection (c) of such Exhibit E.

**STADIUM PARKING FACILITIES  
DEVELOPMENT, OPERATIONS AND USE AGREEMENT**

This Stadium Parking Facilities Development, Operations and Use Agreement (this “Agreement”) is made and entered into by and between **THE METROPOLITAN GOVERNMENT OF NASHVILLE AND DAVIDSON COUNTY** (“Metro”) and **TENNESSEE STADIUM, LLC**, a Delaware limited liability company (“StadCo”), as of \_\_\_\_\_, 2024. Capitalized terms used herein shall have the meanings given to such terms in Exhibit 1 hereof.

**RECITALS**

A. Metro owns approximately sixty-three (63) acres of land, as shown on Exhibit 2 attached hereto (the “Metro Land”).

B. Metro ground leases to the Sports Authority approximately twenty and seventy-eight one-hundredths (20.78) acres of the Metro Land, as shown on Exhibit 2 attached hereto (the “Ground Leased Land”), pursuant to that certain Stadium Site Ground Lease Agreement dated August 25, 2023 between Metro and the Sports Authority.

C. The Sports Authority of The Metropolitan Government of Nashville and Davidson County (the “Sports Authority”) owns an approximately thirty-two (32)-acre parcel of land, as shown on Exhibit 2 attached hereto (the “Sports Authority Land”). Metro has an option to acquire fee title to the Sports Authority Land upon the expiration of the Existing Stadium Lease and the demolition of the Existing Stadium. Upon Metro’s acquisition of fee title to the Sports Authority Land, the Sports Authority Land shall thereafter be included as part of the Metro Land for purposes of this Agreement.

D. Metro, StadCo and the Sports Authority entered into that certain Site Coordination Agreement dated August 25, 2023 (“Site Coordination Agreement”) pursuant to which they agreed to certain terms relating to the development and use of the approximately 95-acres of property located on the East Bank along the Cumberland River defined and described more particularly in the Site Coordination Agreement as the Campus and shown on Exhibit 2 hereto as the “Metro Campus” (the “Campus”), which Campus is comprised of the Metro Land, the Ground Leased Land and the Sports Authority Land and will include a new, first-class, state-of-the-art, enclosed venue for professional football and numerous other sporting, entertainment, cultural and civic events (the “Stadium”), which will be leased by the Sports Authority to StadCo pursuant to the terms of that certain Stadium Lease Agreement, dated as of August 25, 2023 (the “Stadium Lease Agreement”).

E. The Site Coordination Agreement contemplates that portions of the Campus will be improved from time to time and made available from the date hereof until the expiration or earlier termination of the Stadium Lease Agreement for the purpose for providing parking for the Stadium.

F. On or about the date hereof, Metro and TFC Nashville Development LLC (the “IDA Developer”) have entered into that certain Master Development Agreement (the “IDA Development Agreement”), whereby IDA Developer and/or one or more IDA Ground Tenants will develop the Initial Development Area, as applicable, pursuant to the IDA Development Agreement and one or more long-term ground leases to be entered into as provided in the IDA Development Agreement (each, as it may be amended from time to time in accordance with its terms, an “IDA Ground Lease”);

G. On or about the date hereof, Metro, StadCo and the IDA Developer have entered into that certain Campus Operations and Use Agreement (the “COUA”), pursuant to which a body described therein



as the “Campus Coordination Committee” (the “CCC”) will have the authority to coordinate certain operations in connection with events occurring upon the Campus.

H. Metro and StadCo desire to enter into this Agreement to more fully set forth the parking agreements set forth in the Site Coordination Agreement.

### AGREEMENT

For and in consideration of the premises and the mutual covenants and obligations of Metro and StadCo more particularly set forth herein, and other good and valuable consideration, the receipt and sufficiency of which are hereby acknowledged, the parties hereto agree as follows:

1. Development of Parcel B Staging Area and Parking Facilities. The following provisions shall govern the development of Stadium parking and staging facilities in that parcel of Campus property identified in Exhibit 2 as Parcel B (“Parcel B”).

a. StadCo will develop, design and construct Parcel B for use by StadCo, TeamCo and its Related Parties for surface parking, and Metro will provide the use of the land therefor, at no cost or expense to StadCo, except as described in this Agreement. Up to 150,000 sq. ft. of that surface parking space within Parcel B may be used interchangeably as an area available for equipment staging and/or other Stadium Event operational uses (the “Parcel B Staging Area”). The specific location of the Parcel B Staging Area may be located at different locations within Parcel B from time to time, as may be designated by StadCo, subject to the approval of Metro, not to be unreasonably withheld.

b. StadCo will design, develop and construct that number of surface parking spaces in Parcel B that can be configured within the boundaries of Parcel B (inclusive of the Parcel B Staging Area) based on 375 sq. ft. per stall including allocable portion of drive lanes for use by StadCo, TeamCo and their Related Parties as further set forth in this Agreement (the “Parcel B Parking Spaces”). For purposes of clarity, the Parcel B Staging Area will overlap with the Parcel B Parking Spaces.

c. All of the costs required to design, develop and construct the Parcel B Staging Area and the Parcel B Parking Spaces will be performed by StadCo as part of the Stadium Project Improvements Work. For avoidance of doubt, the cost of the Stadium Projects Improvements Work will be included in the Stadium Project Budget. Upon completion of the Stadium Project Improvements Work, StadCo shall provide the Authority and Metro with a drawing depicting the Parcel B Parking Spaces and a statement setting forth the number thereof.

d. The Metropolitan Government may develop, or it may engage the Parcel B Developer to develop, portions of Parcel B, provided that Metro gives prior notice to StadCo, which shall not be less than one hundred and eighty (180) calendar days prior to the first Team Game in the calendar year in which Metro plans to commence construction activities with respect thereto. In such case, Metro shall provide to StadCo temporary replacement parking at the expense of Metro: (i) equal to the number of parking spaces removed from the Parcel B Parking Spaces (with proper dimensions as required by subsection (b) above, together with all attendant lighting, access devices and other improvements necessary for a fully functioning parking facility) as a result of the development of Parcel B (the “Parcel B Replacement Parking Spaces”); (ii) on the site of the Existing Stadium or at another location on the Campus that is agreeable to StadCo; and (iii) no less than thirty (30) calendar days prior to the commencement of any actual construction activities on Parcel B, such that StadCo, TeamCo and its Related Parties will have no interruption (subject to Force Majeure) in the use of such number of parking spaces required to be replaced pursuant to this subsection (d). Any temporary replacement parking provided by Metro pursuant to this subsection (d) shall remain in place until the Substantial Completion of the Parcel B Parking Deck,

the issuance of any certificate required by applicable law for the occupancy thereof and StadCo has been granted access rights to the Parcel B Parking Deck.

e. If the Parcel B development notice is provided to StadCo within the time periods set forth below, Metro shall, from time to time, pay or cause to be paid to StadCo the corresponding amounts within thirty (30) days after commencement of actual construction of the applicable portion of the Parcel B development.

<p style="text-align: center;"><b><u>Time Period</u></b>  “Substantial Completion” means Substantial Completion of the Stadium Project Improvements</p>	<p style="text-align: center;"><b><u>Amount Owed to StadCo</u></b></p>
<p style="text-align: center;">0-1 year after Substantial Completion</p>	<p style="text-align: center;">\$5,000,000, times applicable* Parcel B Replacement Parking Spaces, divided by total Parcel B Parking Spaces</p>
<p style="text-align: center;">1-2 years after Substantial Completion</p>	<p style="text-align: center;">\$4,000,000, times applicable Parcel B Replacement Parking Spaces, divided by total Parcel B Parking Spaces</p>
<p style="text-align: center;">2-3 years after Substantial Completion</p>	<p style="text-align: center;">\$3,000,000, times applicable Parcel B Replacement Parking Spaces, divided by total Parcel B Parking Spaces</p>
<p style="text-align: center;">3-4 years after Substantial Completion</p>	<p style="text-align: center;">\$2,000,000, times applicable Parcel B Replacement Parking Spaces, divided by total Parcel B Parking Spaces</p>
<p style="text-align: center;">4-5 years after Substantial Completion</p>	<p style="text-align: center;">\$1,000,000, times applicable Parcel B Replacement Parking Spaces, divided by total Parcel B Parking Spaces</p>

\*as used in this chart, the term “applicable” refers to the number of Parcel B Replacement Parking Spaces that are the subject of any such notice from Metro.

Regardless of when Metro provides such notice to StadCo, Metro shall be liable for any usual and customary termination fees payable to a parking operator pursuant to any parking operating agreement entered into by StadCo for operation of the Parcel B Parking Spaces in an arm’s length transaction with a third-party operator; provided that no such parking operating agreement shall have a term longer than one year without the prior written consent of Metro. Notwithstanding anything in the foregoing to the contrary, during any construction of improvements on Parcel B, Metro shall preserve one or more areas, functionally available for staging operations and reasonably acceptable to StadCo, with a total surface area of 150,000 sq. ft. of surface space for use by StadCo, TeamCo and its Related Parties for equipment staging and/or other

Stadium Event operational uses for specified Stadium Events identified by StadCo during Stadium Event Operational Periods. During such Stadium Event Operational Periods, neither Metro, nor the Parcel B Developer, if applicable, shall use such 150,000 sq. ft. for construction operations, shall keep it free and clear of its or its contractors' construction equipment, materials and debris and shall ensure such area is fenced off (or otherwise securely and safely separated) from adjacent construction activities by Metro or the Parcel B Developer within Parcel B.

f. Metro shall include, at no cost or expense to StadCo, except as specifically provided herein, structured parking as part of the development of Parcel B, whether as a separate parking facility structure or as a parking facility integrated in one or more other structures developed on Parcel B (the "Parcel B Parking Deck"); for avoidance of doubt, when such parking is integrated into a larger parking structure, the term "Parcel B Parking Deck" shall refer only to those areas within such larger structure(s) that are available for exclusive access to, and use, by StadCo, the StadCo Related Parties and their invitees and are bounded by the unfinished floor, walls and ceiling of such exclusive areas; any such structure into which the Parcel B Parking Deck is integrated is referred to herein as the "Larger Facility"). Metro shall be responsible for the cost to construct the Parcel B Parking Deck. In the event the Parcel B Parking Deck is integrated into a Larger Facility, Metro and StadCo will negotiate in good faith the terms of either (i) a lease agreement for the Parcel B Parking Deck and/or (ii) a condominium declaration for the Parcel B Parking Deck on terms reasonably acceptable to the parties thereto and consistent with the terms and conditions of this Agreement, including without limitation that such parking shall be provided at no cost or expense to StadCo, except as specifically provided herein. Metro's and StadCo's failure to agree upon the terms and conditions of such lease or condominium declaration shall not result in any modification of the rights and obligations of the Parties described herein. The Parcel B Parking Deck shall, at a minimum, include a number of spaces equal to (i) the Parcel B Replacement Parking Spaces minus (ii) 133. Metro shall provide StadCo access to, and the ability to occupy and use, the Parcel B Parking Deck within thirty (30) days after Substantial Completion thereof. StadCo shall have the right to approve the plans for the Parcel B Parking Deck (and, solely as they relate to access, ingress and egress to the Parcel B Parking Deck, the plans for the Larger Facility) and any modifications to each of the foregoing so as to, among other matters, confirm appropriate access, ingress, egress and traffic flow exists, such approval not to be unreasonably withheld, conditioned or delayed (such approved plans, including any modifications thereto, are referred to herein as the "Parcel B Parking Deck Plans"). Metro shall include in all contracts in connection with construction of the Parcel B Parking Deck the requirement that each contractor, subcontractor and material or equipment provider provide industry-standard warranties. Metro may also provide not less than 150,000 sq. ft. of parking area that is functionally available for staging operations, reasonably acceptable to StadCo, either on an undeveloped portion of Parcel B or as part of the Parcel B development. Following the delivery of such 150,000 sq. ft. of parking/staging area, the areas otherwise preserved within Parcel B for staging area may be developed by or on behalf of Metro in the manner set forth above in this Section 1 (but without any further preservation of staging square footage). Once Metro is obligated to provide the Parcel B Replacement Parking Spaces, Metro shall complete construction of the Parcel B Parking Deck within a reasonable time, giving consideration to the facts and circumstances surrounding the nature of the Parcel B Parking Deck to be designed and constructed.

g. If Metro intends to assign to Parcel B Developer, and Parcel B Developer intends to assume, certain rights and obligations under this Agreement, then upon Metro and the Parcel B Developer entering into an agreement pursuant to which the Parcel B Developer has been granted the unconditional right to develop Parcel B and the Parcel B Developer has agreed to assume certain rights and obligations under this Agreement, Metro shall execute, and cause the Parcel B Developer to execute, a joinder agreement pursuant to which Metro assigns certain obligations hereunder, and the Parcel B Developer assumes such obligations. Such joinder shall describe the specific obligations hereunder assigned by Metro and assumed by Parcel B Developer, including without limitation a designation of the number of Parcel B Replacement Parking Spaces that the Parcel B Developer has assumed the obligation to provide on Parcel

B and a legal description of the land upon which such Parcel B Replacement Parking Spaces will be located (the “Applicable Replacement Parking Spaces Land”). Upon the full execution of such joinder, a memorandum (or, if applicable, an amended and restated memorandum) of this Parking Agreement shall be recorded against the Applicable Replacement Parking Spaces Land. Upon Parcel B Developer’s execution of such joinder agreement and the recordation of such memorandum (or, if applicable, amended and restated memorandum), Metro shall be released from all obligations under this Agreement so assumed by the Parcel B Developer.

2. Development of Campus Parking Facilities Outside of Parcel B. The following provisions shall govern the development of Stadium parking facilities in those portions of the Campus located outside of Parcel B.

a. In addition to the parking described in Section 1 above, Metro shall maintain at all times not less than 2,000 structured or surface parking spaces within the Campus outside of (i) Parcel B, and (ii) until the Substantial Completion of the Stadium, current lots identified as S, H, K and J on Exhibit 3. On the date hereof, excluding Parcel B and current lots S, H, K and J, the Campus contains 2,999 parking spaces, a roster for which is attached hereto as Exhibit 3 (the “Existing Campus Parking Spaces”). The parking spaces from time to time satisfying this 2,000-space parking requirement are referred to herein as the “Campus Parking Spaces.” As of the date hereof, the Campus Parking Spaces are comprised of the Existing Campus Parking Spaces, which exceed the 2,000-space requirement.

b. Metro shall have the right, from time to time but at no cost or expense to StadCo, to add to the roster of Campus Parking Spaces those structured or surface parking spaces on such locations within the Campus as Metro may determine. Metro shall memorialize the addition of Campus Parking Spaces by adding an addendum hereto, which addendum shall specify the specific number and location of spaces.

c. Metro shall have the right, from time to time, to remove parking spaces from the roster of Campus Parking Spaces to better facilitate the development of the Campus. Following the removal of such spaces from any parcel within the Campus (a “Removed Parcel”), each Removed Parcel shall no longer be subject to any of the terms of this Agreement. Upon the execution by Metro of an IDA Ground Lease, the parcel subject to the IDA Ground Lease shall become a Removed Parcel. No Campus Parking Space may be removed during any NFL Season unless Metro shall have provided notice of such removal to StadCo at least one hundred and eighty (180) days prior to the first Team Game in such NFL Season. Furthermore, no parking space may be removed, if such removal would cause the total number of Campus Parking Spaces to be less than 2,000, unless Metro shall have provided for the addition of a sufficient number of Campus Parking Spaces pursuant to subsection (b) above, in locations within the Campus, such that upon the proposed removal of the parking spaces, the total number of Campus Parking Spaces will continue to equal or exceed 2,000.

d. While Metro may pursue an independent technology solution if, after meeting in good faith, it determines that a joint approach is not practicable or in its best interest, Metro shall use commercially reasonable efforts to integrate StadCo’s technology partners in the course of the design, development and operations of the Campus Parking Spaces, to achieve coordinated mobile technology, which efforts may include participating in meetings with StadCo’s technology partners and including such partners in requests for proposals and other similar opportunities to (i) enhance the experience of attending Stadium Events and being in the Campus and (ii) achieve revenue and cost synergies.

e. In addition to the parking that Metro is obligated to provide hereunder (some of which obligations may be satisfied by the Parcel B Developer), Metro will seek to require each Campus Developer to provide any parking facilities included in any Campus improvements to be available for StadCo for parking with respect to Stadium Events on a reasonable basis taking into account the developer’s own parking needs for its tenants and their invitees

f. The parties acknowledge that, until the Substantial Completion of the Stadium, StadCo's rights and responsibilities relative to current lots identified as S, H, K and J on Exhibit 3 are set forth in the Existing Stadium Lease. Following the expiration of the Existing Stadium Lease, StadCo shall have no rights with respect to the use of current lots identified as S, H, K and J.

g. StadCo and Metro will cooperate to maximize the number of parking spaces that can be added in connection with the anticipated alteration of the Colonial gas pipeline that will occur as part of the Stadium Projects Improvement Work, and any such additional spaces not located within the Initial Development Area shall be added to parking inventory and can be included within the Campus Parking Spaces.

h. Metro shall not be permitted to satisfy its obligations under this Section 2 by locating any Campus Parking Spaces on Sports Authority Land, prior to the acquisition of the Sports Authority Land by Metro, without either (i) StadCo's prior written consent or (ii) the execution by the Sports Authority of a joinder to this Agreement relating to, and assuming, all obligations described hereunder as those of Metro with respect to such Campus Parking Spaces.

i. Notwithstanding anything in this Section 2 to the contrary, the minimum number of Campus Parking Spaces shall be reduced to 1,500 during the period commencing with the conclusion of the 2024-2025 NFL Season and concluding on the 90th day following the demolition of the Existing Stadium (the "Campus Construction Period"); provided, however, during the Campus Construction Period, Metro shall not be permitted to remove parking spaces from the roster of Campus Parking Spaces pursuant to subsection (c) above if such removal would cause the total number of Campus Parking Spaces to be less than 2,000 unless (1) no fewer than thirty (30) calendar days prior to the date on which such parking spaces are to be removed from the roster of Campus Parking Spaces, Metro has provided, at its sole cost and expense, a sufficient number of Off-Campus Parking Spaces (as defined below) to ensure that StadCo, TeamCo and their Related Parties will have no interruption (subject to Force Majeure) in the availability for their use of a minimum of 2,000 (in the aggregate) Campus Parking Spaces and Off-Campus Parking Spaces; and (2) such removal of parking spaces from the roster of Campus Parking Spaces has been confirmed by Metro in the notice of removal delivered to StadCo pursuant to subsection (c) above to be necessary to facilitate the development of the Campus. In accordance with clause (2) of the immediately preceding sentence, during the Campus Construction Period, Metro shall take all reasonable steps to minimize the number and aggregate surface area of construction and ancillary lay-down areas and shall otherwise cooperate with StadCo to maximize the aggregate surface area within the Campus that may be used for Campus Parking Spaces. For purposes of this subsection (i), "Off-Campus Parking Spaces" shall mean parking spaces usable during Stadium Event Operational Periods and located on the east side of the Cumberland River no further than one-half (1/2) of a mile from the boundaries of the Campus, or at such other locations as may be expressly agreed to by StadCo.

3. Agreements as to Use and Operation of the Parcel B Parking Spaces, the Parcel B Replacement Parking Spaces, the Parcel B Parking Deck and the Parcel B Staging Area.

a. Subject to all of the terms and provisions hereof (including without limitation the right of Metro to cause the development of Parcel B in accordance with the provisions of Section 1), StadCo and its agents, employees, guests, invitees and patrons shall have the exclusive right to use at all times (i) the Parcel B Parking Spaces and the Parcel B Replacement Parking Spaces for the parking of motor vehicles, (ii) the Parcel B Staging Area, interchangeably as an area available for the parking of motor vehicles, equipment staging and/or other Stadium Event operational uses, and (iii) the Parcel B Parking Deck for the parking of motor vehicles and, in the event space therein is provided in replacement of all or a portion of the Parcel B Staging Area, interchangeably as an area available for the parking of motor vehicles, equipment staging and/or other Stadium Event operational uses. StadCo's guests, invitees and patrons shall, during any Stadium Event Parking Period, be permitted to cook and otherwise prepare and

consume food and beverages on the Parcel B Parking Spaces, the Parcel B Replacement Parking Spaces, and the Parcel B Staging Area; provided, however, in no event shall any sales of foods or alcoholic beverages be permitted at any time within any of such areas. Within six hours following the end of each Stadium Event Parking Period, StadCo shall cause all debris and trash to be removed from the Parcel B Parking Spaces, the Parcel B Replacement Parking Spaces and the Parcel B Parking Deck so that the same are in a neat, attractive and clean condition.

b. StadCo shall not cause any material interference with ingress and egress to the Parcel B Replacement Parking Spaces and shall maintain and preserve adequate ingress and egress to the Parcel B Parking Spaces and Parcel B Staging Area, and shall maintain signage and lighting at the site of the Parcel B Parking Spaces, Parcel B Replacement Parking Spaces and Parcel B Staging Area to provide for adequate safety and visibility thereon; provided however, that this Agreement shall in no way constitute a guarantee by StadCo of the safety or security of any persons or property.

c. StadCo shall perform, at its sole cost and expense, all maintenance and capital repair work with respect to the Parcel B Parking Spaces, Parcel B Replacement Parking Spaces, the Parcel B Parking Deck and Parcel B Staging Area necessary to maintain the Parcel B Parking Spaces, Parcel B Replacement Parking Spaces, the Parcel B Parking Deck and Parcel B Staging Area in a manner reasonably consistent with parking facilities at Comparable NFL Facilities; provided, StadCo may require Metro to perform, at Metro's sole cost and expense (subject to the provisions of Section 7), within the Parcel B Parking Deck, any Facility-Wide Capital Repairs that are necessary to maintain the Parcel B Parking Deck in a manner reasonably consistent with parking facilities at Comparable NFL Facilities.

d. Subject to the provisions of Section 7, Metro shall (i) maintain and preserve adequate ingress and egress to the Parcel B Parking Deck and shall not cause any material interference with ingress and egress to the Parcel B Replacement Parking Spaces, (ii) shall maintain signage and lighting at the site of the Parcel B Parking Deck to provide for adequate safety and visibility thereon, (iii) shall maintain the exterior of the Larger Facility in a safe and sightly condition, (iv) shall perform the Facility-Wide Capital Repairs within the Parcel B Parking Deck, to the extent required by StadCo pursuant to Section 3(c); and (v) shall perform reasonably necessary Facility-Wide Capital Repairs to portions of the Larger Facility, other than the Parcel B Parking Deck; provided however, that this Agreement shall in no way constitute a guarantee by Metro of the safety or security of any persons or property.

e. If the Parcel B Parking Spaces, Parcel B Replacement Parking Spaces, Parcel B Parking Deck or Parcel B Staging Area becomes wholly or partially untenable during the Term, whether by reason of fire, lightning, snow or rain or any other casualty (a "Casualty"), StadCo shall repair, restore, or rehabilitate the Parcel B Parking Spaces, Parcel B Replacement Parking Spaces, Parcel B Parking Deck or Parcel B Staging Area, as applicable. StadCo shall exercise due diligence so as to place the Parcel B Parking Spaces, Parcel B Replacement Parking Spaces, Parcel B Parking Deck and Parcel B Staging Area in substantially the same condition as prior to the occurrence of the Casualty, without affecting the provisions of this Agreement. Due allowance shall be made for reasonable delay which may be caused by adjusting of insurance, strikes, labor difficulties or any cause beyond StadCo's control. Provided that StadCo is otherwise in compliance with its obligations under this subsection (e), the inability of StadCo to fully satisfy its obligations under this Section 3 as a result of a Casualty shall not constitute an Event of Default hereunder.

f. If the Larger Facility becomes wholly or partially untenable during the Term by reason of a Casualty such that (i) StadCo cannot restore the Parcel B Parking Deck until the Larger Facility is restored, (ii) automobile or pedestrian access, ingress or egress to or from the Parcel B Parking Deck is not substantially equivalent to the access, ingress and egress contemplated by the Parcel B Parking Deck Plans, or (iii) the exterior of the Larger Facility or the portions of the Larger Facility through which StadCo

or its Related Parties access the Parcel B Parking Deck are unsightly or unsafe, Metro shall either (X) demolish the Larger Facility and provide surface parking lot(s) in the same location as the Parcel B Parking Spaces with sufficient parking spaces to include the Parcel B Replacement Parking Spaces; or (Y) repair, restore, or rehabilitate the Larger Facility, to the extent necessary: (I) to permit StadCo to restore the Parcel B Parking Deck, as required by this Agreement, (II) such that automobile and pedestrian access, ingress and egress to and from the Parcel B Parking Deck is substantially equivalent to that contemplated by the Parcel B Parking Deck Plans, and (III) such that the exterior of the Larger Facility and the portions of the Larger Facility through which StadCo or its Related Parties access the Parcel B Parking Deck are sightly and safe. Metro shall exercise due diligence to perform all such restoration. Due allowance shall be made for reasonable delay which may be caused by adjusting of insurance, strikes, labor difficulties or any cause beyond the control of Metro. Provided that Metro is otherwise in compliance with its obligations under this subsection (f), the inability of Metro to fully satisfy its obligations under this Section 3 as a result of a Casualty shall not constitute an Event of Default hereunder.

g. Once the Parcel B Parking Spaces and Parcel B Staging Area, respectively, are completed, StadCo shall make no material alterations or changes to, nor construct any permanent or temporary improvements upon, the Parcel B Parking Spaces or the Parcel B Staging Area, respectively, or any portion thereof, without the express prior written consent of Metro, except that StadCo may make temporary alterations to the Parcel B Staging Area, to the extent the same are reasonably necessary in connection with staging operations and will not cause a material adverse effect to the Campus, without Metro's consent.

h. StadCo shall comply with all laws, rules, regulations and codes, whether now existing or hereafter arising, in regard to the parking of vehicles upon or any other use of the Parcel B Parking Spaces, Parcel B Replacement Parking Spaces and the Parcel B Staging Area.

i. Once the Parcel B Parking Deck has been completed, neither Metro nor, if applicable the Parcel B Developer shall make any material alterations or changes thereto that would materially adversely impact StadCo's use of the Parcel B Parking Deck, nor construct any permanent or temporary improvements thereupon that would materially adversely impact StadCo's use of the Parcel B Parking Deck, or any portion thereof, without the express prior written consent of StadCo.

j. StadCo shall bear the financial responsibility for all third-party claims for personal injury, property damage or otherwise, arising out of or in connection with the operation of the Parcel B Parking Spaces, the Parcel B Replacement Parking Spaces, the Parcel B Staging Area and the Parcel B Parking Deck (but, for avoidance of doubt, not with respect to claims related to the construction of the Parcel B Parking Deck, Metro's or its Related Parties' performance of Facility-Wide Capital Repairs to the Parcel B Parking Deck, to the extent Metro or its Related Parties make such repairs or are obligated to make such repairs pursuant to Section 3d, or Metro's or its Related Parties' operation of the Larger Facility).

k. StadCo shall permit the Sports Authority to utilize a reasonable number of the Parcel B Parking Spaces, Parcel B Replacement Parking Spaces and the Parcel B Parking Deck, as requested from time to time, for meetings of the Board of Directors of the Sports Authority and other business of the Sports Authority, provided that the same use does not materially adversely affect the rights of StadCo or its invitees to use parking spaces within the Parcel B Parking Spaces, Parcel B Replacement Parking Spaces and the Parcel B Parking Deck in the amounts provided for herein. For the avoidance of doubt, the business of the Sports Authority is not intended, for purposes of this subsection (k), to include Authority Events or Stadium Events.

4. Agreements as to Use and Operation of the Campus Parking Spaces.

a. Subject to all of the terms and provisions hereof, StadCo and its agents, employees, guests, invitees and patrons shall have the exclusive right to use the Campus Parking Spaces for the parking of motor vehicles during Stadium Event Parking Periods. StadCo's guests, invitees and patrons shall, during Stadium Event Parking Periods, be permitted to cook (other than within any parking structure located within the Campus) and otherwise prepare and consume food and beverages on the Campus Parking Spaces; provided, however, in no event shall any sales of foods or alcoholic beverages be permitted on the Campus Parking Spaces without the prior express written consent of Metro. Unless otherwise approved by the CCC, and provided that Metro's rights to provide parking on the following day are not materially adversely affected, the parties agree to cause the Campus Parking Space Operator to cause all debris and trash to be removed from the Campus Parking Spaces so that the same are in a neat, attractive and clean condition prior to 6:00 a.m. on the day immediately following any Stadium Event.

b. Metro shall maintain and preserve adequate ingress and egress to the Campus Parking Spaces, and shall maintain signage and lighting at the site of the Campus Parking Spaces to provide for adequate safety and visibility thereon consistent with the same at Comparable NFL Facilities; provided however, that this Agreement shall in no way constitute a guarantee by Metro of the safety or security of any persons or property.

c. Metro shall perform all maintenance and capital repair work with respect to the Campus Parking Spaces necessary to maintain the Campus Parking Spaces in a manner reasonably consistent with parking facilities at Comparable NFL Facilities, taking into account age, size, design, and other relevant factors for parking facilities at such Comparable NFL Facilities.

d. Metro shall bear the financial responsibility for all third-party claims for personal injury, property damage or otherwise, arising out of or in connection with the Campus Parking Spaces other than those that are described as the responsibility of StadCo in the next sentence. StadCo shall bear the financial responsibility for all third-party claims for personal injury, property damage or otherwise, arising out of or in connection with the Campus Parking Spaces during Stadium Event Parking Periods, except to the extent arising from the negligence or willful misconduct of Metro.

e. Metro shall ensure that the Campus Parking Spaces are available for use by StadCo during the Stadium Event Parking Periods, and shall tow or otherwise remove, and Metro hereby authorizes StadCo to tow or otherwise remove, in each case at Metro's expense, all vehicles remaining at the Campus Parking Spaces prior to each Stadium Event Parking Period. Likewise, Metro expects that the Campus Parking Spaces will be available for use by Metro immediately following the conclusion of each Stadium Event Parking Period. To that end, Metro shall be permitted to tow or otherwise remove all vehicles remaining at the Campus Parking Spaces following each Stadium Event Parking Period, pursuant to towing policies approved by or on behalf of Metro, and at no cost to StadCo.

f. If Campus Parking Spaces become wholly or partially untenable during the Term as a result of a Casualty, Metro shall repair, restore, or rehabilitate the Campus Parking Spaces. Metro shall exercise due diligence so as to place the Campus Parking Spaces in substantially the same condition as prior to the occurrence of the Casualty, without affecting the provisions of this Agreement. Due allowance shall be made for reasonable delay which may be caused by adjusting of insurance, strikes, labor difficulties or any cause beyond Metro's control. Provided that Metro is otherwise in compliance with its obligations under this subsection (f), the inability to Metro to provide 2,000 Campus Parking Spaces as a result of a Casualty shall not constitute an Event of Default hereunder.



g. Metro agrees to take commercially reasonable steps necessary at its own cost and expense to prevent any advertisers within the facilities containing Campus Parking Spaces from engaging in Ambush Marketing, which steps shall include, but not be limited to, Metro reasonably cooperating to develop and implement an Ambush Marketing protection strategy to combat any such Ambush Marketing. Metro will use commercially reasonable efforts to notify StadCo promptly in writing of any suspected instances of Ambush Marketing located within the facilities containing Campus Parking Spaces, or infringement of, or upon becoming aware of any unauthorized use of, TeamCo's or StadCo's intellectual property located within the facilities containing Campus Parking Spaces, and will use commercially reasonable efforts to assist TeamCo and StadCo in protecting TeamCo and StadCo intellectual property from the aforementioned activities occurring within the facilities containing Campus Parking Spaces. Nothing in this subsection (g) imposes any obligation on Metro or StadCo (or TeamCo, the NFL or any NFL Entity, where applicable) to commence proceedings or to take enforcement action against a third party.

h. Metro shall use commercially reasonable efforts to prevent Negative Advertising against StadCo and TeamCo and their Affiliates and their respective sponsors and other business parties (each to the extent identified in a specific written notice from StadCo to Metro from time to time) from occurring on the facilities containing Campus Parking Spaces.

5. Parking Operators.

a. StadCo shall operate or engage a parking operator (the "Parcel B Parking Operator") to manage and operate the Parcel B Parking Spaces, Parcel B Staging Area and Parcel B Parking Deck, such that the Parcel B Parking Spaces, Parcel B Staging Area and Parcel B Parking Deck are operated and maintained in good condition and repair and in a manner reasonably consistent with parking and staging plans for Comparable NFL Facilities, subject to obligations of Metro specifically described herein with respect to Facility-Wide Capital Repairs. StadCo shall work with the Parcel B Parking Operator to ensure safe and efficient parking management, traffic control and security in and about the Parcel B Parking Spaces, Parcel B Staging Area and Parcel B Parking Deck at all times.

b. Metro shall operate or engage a parking operator reasonably acceptable to StadCo (the "Campus Parking Space Operator"), upon terms and conditions reasonably acceptable to StadCo, to manage and operate the Campus Parking Spaces, such that the Campus Parking Spaces are operated and maintained in good condition and repair and in a manner reasonably consistent with parking plans for Comparable NFL Facilities. Metro and StadCo shall work with the Campus Parking Space Operator to ensure safe and efficient parking management, traffic control and security in and about the Campus Parking Spaces during each Stadium Event Parking Period.

6. Allocation of Parking Revenues

a. StadCo shall have the sole and exclusive right to all Parking Revenue derived from the Parcel B Parking Spaces, the Parcel B Staging Area, the Parcel B Replacement Parking Spaces and the Parcel B Parking Deck. StadCo shall not operate the Parcel B Parking Deck as a commercial parking facility that would compete with other parking facilities on the Campus for public parking during times other than the Stadium Event Parking Periods.

b. StadCo shall have the sole and exclusive right to all Parking Revenue derived from the Campus Parking Spaces during Stadium Event Parking Periods.

c. Metro shall have the sole and exclusive right to all Parking Revenues derived from the Campus Parking Spaces during all times other than the Stadium Event Parking Periods.

7. Allocation of Parking Expenses

a. StadCo shall be solely responsible for the ongoing capital and operating expenses required to maintain the Parcel B Parking Spaces and the Parcel B Replacement Parking Spaces in accordance with the terms of this Agreement, including the costs of the Parcel B Parking Operator.

b. StadCo shall be solely responsible for the ongoing capital and operating expenses related to work performed within the Parcel B Parking Deck required to maintain the Parcel B Parking Deck in accordance with the terms of this Agreement, including the costs of the Parcel B Parking Operator but specifically excluding capital expenses incurred in connection with work performed in the Parcel B Parking Deck that relates to Structure or Systems. Metro shall be solely responsible for the capital expenses related to the Parcel B Parking Deck, to the extent such capital expenses relate to the Structure or Systems. Upon StadCo's demand, Metro shall reimburse StadCo for (i) the reasonable out-of-pocket costs and expenses incurred by StadCo in connection with the performance within the Parcel B Parking Deck of Facility-Wide Capital Repairs that relate to the Structure or Systems, and (ii) the reasonable out-of-pocket costs and expenses incurred by StadCo in connection with the performance within the Parcel B Parking Deck of all other Facility-Wide Capital Repairs, to the extent such costs and expenses incurred by StadCo exceed StadCo's Pro Rata Share of the costs and expenses for such Facility-Wide Capital Repairs project.

c. Metro shall be responsible for the capital and operating expenses required to maintain the Larger Facility in accordance with its obligations under Section 3d; provided, StadCo shall be responsible for StadCo's Pro Rata Share of the reasonable capital expenses incurred by Metro in connection with the Facility-Wide Capital Repairs (other than capital expenses related to the Structure or Systems, which shall be expenses solely of Metro), such expenses to be subject the prior approval of StadCo, such approval not to be unreasonably withheld, conditioned or delayed. As used herein, "StadCo's Pro Rata Share" means the percentage obtained by dividing (i) the total number of parking spaces within the Parcel B Parking Deck by (ii) the total number of parking spaces within the Larger Facility. Reimbursement shall be made for each 12-month period ending June 30, upon the provision by Metro to StadCo of the expense detail for such 12-month period

d. Metro shall be responsible for the capital and operating expenses required to maintain the Campus Parking Spaces in accordance with the terms of this Agreement, including the costs of the Campus Parking Space Operator (including any parking management fee and/or expense reimbursement payable to the Campus Parking Space Operator); provided that StadCo shall reimburse Metro for (i) the costs of the Campus Parking Space Operator during Stadium Event Parking Periods, and (ii) the Stadium Event Portion (as defined below) of all repair and maintenance (including, without limitation, repaving and resurfacing) expenses incurred by Metro, which shall be subject to approval by StadCo, such approval not to be unreasonably withheld, conditioned or delayed, in connection with the operation of the Campus Parking Spaces. Reimbursement shall be made for each 12-month period ending June 30, upon the provision by Metro to StadCo of the expense detail for such 12-month period. "Stadium Event Portion," for any such 12-month period, shall mean the percentage obtained by dividing (i) the total number of users of the Campus Parking Spaces during Stadium Events within such 12-month period by (ii) the total number of users of the Campus Parking Spaces within such 12-month period. Metro shall provide StadCo with such books and records (A) regarding repair and maintenance expenses incurred by Metro, and (B) that are the basis for Metro's calculation of the applicable Stadium Event Portion as StadCo shall reasonably request.

8. Right to Use.

a. Metro hereby grants to StadCo, and StadCo hereby accepts from Metro, the right to use the Parcel B Parking Spaces, Parcel B Staging Area, Parcel B Replacement Parking Spaces and

Parcel B Parking Deck for the consideration and upon the terms and conditions set forth in this Agreement. This right shall extend for the entire Term, subject only to (i) the right of Metro to cause the development of Parcel B in the manner described in Section 1, and (ii) the expiration of StadCo's rights to Parcel B Replacement Parking Spaces upon Substantial Completion of the Parcel B Parking Deck, receipt of any required governmental permits or approvals for the occupancy thereof and StadCo's being provided access to the Parcel B Parking Deck. StadCo hereby accepts the Parcel B Parking Spaces, Parcel B Staging Area and Parcel B Replacement Parking Spaces in their as is, where is condition, with all faults.

b. Metro hereby grants to StadCo, and StadCo hereby accepts from Metro, the right to use the Campus Parking Spaces during Stadium Event Parking Periods upon the terms and conditions set forth herein. This right shall extend for the entire term of this Agreement. StadCo hereby accepts the Campus Parking Spaces in their as is, where is condition, with all faults.

c. The grants described in this Section 8 are irrevocable during the term of the Stadium Lease Agreement.

9. Term. Subject to and upon the terms and conditions set forth in this Agreement, the term of this Agreement (the "Term") shall commence on the date hereof and shall conclude upon the expiration or earlier termination of the Stadium Lease Agreement.

10. Insurance; Indemnity.

a. StadCo shall, at its own expense, maintain at all times during the Term following Substantial Completion of, and StadCo's having been given access to, the Parcel B Parking Spaces, Parcel B Staging Area, Parcel B Replacement Parking Spaces, Parcel B Parking Deck and the Campus Parking Spaces, respectively, policies of insurance covering StadCo's use of such respective parking spaces or staging area in the following types and amounts, or if not reasonably available, the most nearly equivalent coverages as are reasonably available, with the premiums thereon fully paid on or before the due date:

i. All-risk property insurance on the Parcel B Parking Deck and all improvements constructed therein, which shall cover loss or damage by fire and other hazards commonly insured under an all-risk policy, if reasonably available, and shall be in an amount sufficient to cover the full replacement cost of any repair or reconstruction in the event of damage or destruction from any such hazard;

ii. Commercial general liability insurance, including contractual liability coverage, with a combined single limit of at least \$2,000,000.00 per occurrence, with respect to bodily injury, personal injury, and property damage that may arise from use of the Parcel B Parking Spaces, Parcel B Staging Area, Parcel B Replacement Parking Spaces, Parcel B Parking Deck and the Campus Parking Spaces by StadCo, its Affiliates and their respective invitees;

iii. Workers compensation insurance and employers' liability insurance covering all persons employed by StadCo and any contractors, subcontractors, or other persons performing work on the Parcel B Parking Spaces, Parcel B Staging Area, Parcel B Replacement Parking Spaces, Parcel B Parking Deck and the Campus Parking Spaces if and to the extent required by law; and

iv. Such additional insurance as may otherwise be required by law.

Any such policy or policies with respect to the Parcel B Parking Spaces, Parcel B Staging Area, Parcel B Replacement Parking Spaces, Parcel B Parking Deck and the Campus Parking Spaces shall name Metro, the Sports Authority and the Parcel B Developer (if applicable) as additional insureds. From time to time, the Parties may discuss reasonable modifications to the foregoing requirements, based on the facts and circumstances existing at such time.

b. StadCo shall provide Metro and, to the extent the Parcel B Developer has assumed any of Metro's obligations hereunder, the Parcel B Developer (if applicable) copies of insurance binders (or certificates in lieu thereof) with respect to the insurance policies to be maintained in compliance with this Agreement no later than thirty (30) days prior to the date on which such policies are to be effective and copies or certificates of such policies as soon as possible after the effective date of such policies. Each such binder and policy shall name Metro, the Sports Authority and the Parcel B Developer (if applicable) as additional insureds, and shall provide that it may not be amended, modified or canceled without thirty (30) days' prior notice to Metro, the Sports Authority and the Parcel B Developer (if applicable). If StadCo fails to provide insurance as required, Metro or the Parcel B Developer (if applicable), upon ten (10) days' notice to StadCo and StadCo's failure to correct such failure within said ten (10) days, may provide such insurance as StadCo's agent and in StadCo's name, and until such time as StadCo so insures (which for the purposes of this provision may only be on a subsequent renewal date), StadCo shall reimburse Metro or the Parcel B Developer (if applicable) for premiums paid by Metro or the Parcel B Developer (if applicable) for same, plus interest at the maximum rate permitted by applicable law.

c. From and after such time as Parcel B Developer assumes some or all of Metro's obligations hereunder regarding the Parcel B Parking Deck the Parcel B Developer shall, at its own expense, maintain at all times during the Term following Substantial Completion of, and StadCo's having been given access to, the Parcel B Parking Deck, the policies of insurance in the following types and amounts, or if not reasonably available, the most nearly equivalent coverages as are reasonably available, with the premiums thereon fully paid on or before the due date:

i. All-risk property insurance on the Larger Facility and all improvements constructed therein (excluding those within the Parcel B Parking Deck), which shall cover loss or damage by fire and other hazards commonly insured under an all-risk policy, if reasonably available, and shall be in an amount sufficient to cover the full replacement cost of any repair or reconstruction in the event of damage or destruction from any such hazard;

ii. Commercial general liability insurance, including contractual liability coverage, with a combined single limit of at least \$2,000,000.00 per occurrence, with respect to bodily injury, personal injury, and property damage that may arise from use of the Larger Facility by Parcel B Developer, StadCo, either of their Affiliates and their respective invitees;

iii. Workers compensation insurance and employers' liability insurance covering all persons employed by Parcel B Developer and any contractors, subcontractors, or other persons performing work on the Parcel B Parking Deck if and to the extent required by law; and

iv. Such additional insurance as may otherwise be required by law.

d. All such policy or policies with respect to the Larger Facility shall name StadCo and TeamCo as additional insureds. From time to time, the Parties may discuss reasonable modifications to the foregoing requirements, based on the facts and circumstances existing at such time.

e. From and after such time as Parcel B Developer assumes some or all of Metro's obligations hereunder regarding the Parcel B Parking Deck, the Parcel B Developer shall provide Metro and StadCo copies of insurance binders (or certificates in lieu thereof) with respect to the insurance policies to be maintained in compliance with this Agreement no later than thirty (30) days prior to the date on which such policies are to be effective and copies or certificates of such policies as soon as possible after the effective date of such policies. Each such binder and policy shall name Metro, StadCo and TeamCo as additional insureds, and shall provide that it may not be amended, modified or canceled without thirty (30) days' prior notice to Metro, StadCo and TeamCo. If Parcel B Developer fails to provide insurance as required, Metro or StadCo, upon ten (10) days' notice to the Parcel B Developer and the Parcel B Developer's failure to correct such failure within said ten (10) days, may provide such insurance as the Parcel B Developer's agent and in the Parcel B Developer's name, and until such time as the Parcel B Developer so insures (which for the purposes of this provision may only be on a subsequent renewal date), the Parcel B Developer shall reimburse Metro and StadCo for premiums paid by Metro or StadCo for the same, plus interest at the maximum rate permitted by applicable law.

f. All primary coverage required under this Agreement shall be written by an insurer that is nationally recognized with a policyholder's rating of at least A, IX, as listed from time to time by A.M. Best Insurance Reports. Each policy shall contain mutual waivers of (i) all rights of subrogation, and (ii) any recourse against any Parties other than the insured for payment of any premiums or assessments under such policy. Each policy covering third-party liability shall contain a "cross-liability" endorsement or a "severability of interest" endorsement providing that coverage, to the maximum amount of the policy, will be available despite any suit between the insured and any additional insured under such policy. The insurance policies shall not in the aggregate have deductibles in excess of \$100,000.

g. TO THE EXTENT PERMITTED BY APPLICABLE LAW, AND WITHOUT AFFECTING THE INSURANCE COVERAGES REQUIRED TO BE MAINTAINED HEREUNDER OR AS MAY BE SUBSEQUENTLY DEVELOPED BY THE PARTIES, METRO, THE AUTHORITY, STADCO, AND IF PARCEL B DEVELOPER ASSUMES SOME OR ALL OF METRO'S OBLIGATIONS HEREUNDER REGARDING THE PARCEL B PARKING DECK, THE PARCEL B DEVELOPER AND THEIR AFFILIATES EACH WAIVE ALL RIGHTS OF RECOVERY, CLAIM, ACTION OR CAUSE OF ACTION AGAINST THE OTHER FOR ANY DAMAGE TO PROPERTY, AND RELEASE EACH OTHER FOR SAME, TO THE EXTENT THAT SUCH DAMAGE (A) IS COVERED (AND ONLY TO THE EXTENT OF SUCH COVERAGE WITHOUT REGARD TO DEDUCTIBLES) BY PROPERTY INSURANCE ACTUALLY CARRIED BY THE PARTY HOLDING OR ASSERTING SUCH CLAIM OR (B) WOULD BE INSURED AGAINST UNDER THE TERMS OF ANY INSURANCE REQUIRED TO BE CARRIED UNDER THIS AGREEMENT BY THE PARTY HOLDING OR ASSERTING SUCH CLAIM. THIS PROVISION IS INTENDED TO RESTRICT EACH PARTY (IF AND TO THE EXTENT PERMITTED BY APPLICABLE LAW) TO RECOVERY AGAINST INSURANCE CARRIERS TO THE EXTENT OF SUCH COVERAGE AND TO WAIVE (TO THE EXTENT OF SUCH COVERAGE), FOR THE BENEFIT OF EACH PARTY, RIGHTS OR CLAIMS WHICH MIGHT GIVE RISE TO A RIGHT OF SUBROGATION IN ANY INSURANCE CARRIER. NEITHER THE ISSUANCE OF ANY INSURANCE POLICY REQUIRED UNDER, OR THE MINIMUM LIMITS SPECIFIED HEREIN SHALL BE DEEMED TO LIMIT OR RESTRICT IN ANY WAY A PARTY'S LIABILITY ARISING UNDER OR OUT OF THIS AGREEMENT PURSUANT TO THE TERMS HEREOF.

h. StadCo shall indemnify and hold harmless the Authority Indemnified Persons, the Metropolitan Government Indemnified Persons and the Parcel B Developer Indemnified Persons (to the extent applicable) against and from any and all liabilities, obligations, damages, claims, costs, charges and expenses, including, without limitation, fees and expenses of attorneys, expert witnesses, architects, engineers and other consultants (collectively, "Loss") that may be imposed upon, incurred by or asserted

against any Authority Indemnified Persons, Metropolitan Government Indemnified Persons or the Parcel B Developer Indemnified Persons, by reason of any of the following occurring during the Term (other than those arising out of the negligence or misconduct of any of the Authority Indemnified Persons, Metropolitan Government Indemnified Persons or the Parcel B Developer Indemnified Persons):

- i. any work done by or omitted or failed to be done by StadCo or the Controlled StadCo Permittees in, on, or about the Parcel B Parking Spaces, Parcel B Staging Area, the Parcel B Parking Deck or any part thereof;
- ii. any use, possession, occupation, condition, operation, maintenance or management of the Parcel B Staging Area or the Parcel B Parking Spaces or the Parcel B Parking Deck or any part thereof by StadCo or the Controlled StadCo Permittees;
- iii. any use, possession or occupation of the Parcel B Replacement Parking Spaces or the Campus Parking Spaces or any part thereof by StadCo or the Controlled StadCo Permittees during Stadium Event Parking Periods;
- iv. any negligent, tortious, willful or criminal act of StadCo or the Controlled StadCo Permittees with respect to the Parcel B Parking Spaces, Parcel B Staging Area, Parcel B Parking Deck, the Parcel B Replacement Parking Spaces, the Campus Parking Spaces or any part thereof; and
- v. any failure by StadCo to perform its obligations under this Agreement.

The provisions of this paragraph shall survive the termination of this Agreement with respect to any acts, events, omissions or occurrences occurring before such termination.

11. From and after such time as Parcel B Developer assumes some or all of Metro's obligations hereunder regarding the Parcel B Parking Deck, to the fullest extent permitted by applicable law, the Parcel B Developer agrees to defend, indemnify and hold harmless StadCo and its Affiliates from and against all Losses to the extent: (i) arising from a breach by the Parcel B Developer of its obligations under this Agreement, (ii) arising out of or in any way incidental to any demolition or construction (to the extent that the demolition or construction is performed by the Parcel B Developer or a Parcel B Parking Deck Contractor) of the Parcel B Parking Deck incurred by or on behalf of StadCo or any StadCo Related Party, or any invitee or guest of StadCo; or (iii) caused by the negligent acts or omissions of the Parcel B Developer or a Parcel B Parking Deck Contractor in performing any work or services on the Parcel B Parking Deck, provided that such Loss results from bodily injury, sickness, disease or death or damage to property, including loss of use resulting therefrom. The Parcel B Developer's defense, indemnity and hold harmless obligation shall not extend to the sole negligence of an indemnified party. The provisions of this paragraph shall survive the termination of this Agreement with respect to any acts, events, omissions or occurrences occurring before such termination.

12. No Licenses. To Metro's knowledge there are no currently existing leases, licenses, contracts, agreements or other documents affecting the Campus Parking Spaces that grant any right that is inconsistent with, or conflicts in any manner with, any of the rights granted to StadCo under this Agreement.

13. Assignment/Subletting. Metro shall have the right to assign this Agreement to any agency or instrumentality of the Metropolitan Government, so long as such agency or instrumentality has the right and authority to fulfill Metro's obligations hereunder; otherwise, except as provided in Section 1f, Metro shall only have the right to assign its obligations hereunder as provided in this Agreement; provided, however, if the Parcel B Developer assumes some or all of Metro's obligations hereunder regarding the Parcel B Parking Deck, the Parcel B Developer shall have the right to assign its rights and obligations hereunder to its Mortgagee or to any successors or assigns of the Parcel B Developer that leases from Metro the portion of Parcel B on which the Parcel B Parking Deck is located. The rights of StadCo hereunder shall automatically be deemed assigned by StadCo to any person or entity to whom the rights of the tenant

under the Stadium Lease Agreement have been assigned and StadCo shall have the right to assign its rights and obligations hereunder to its Mortgagee; otherwise StadCo shall not have the right to assign, license or grant any person or entity its rights hereunder.

14. Authority Events. Metro shall have the right to make available the Campus Parking Spaces to the Sports Authority in connection with Authority Events on such terms and conditions as may be agreed to, from time to time, between Metro and the Sports Authority so long as Metro continues to satisfy its obligations to StadCo hereunder.

15. Events of Default and Remedies. The occurrence of any one or more of the following events shall constitute an “Event of Default”:

a. A Party’s failure to pay any amounts due hereunder within thirty (30) days of a written request for the payment thereof from the Party to whom the sum is due; or

b. if (i) a Party fails to observe or perform any material covenant, condition, agreement or obligation hereunder (other than the Party’s obligations referenced in subsection (a) above) so long as such failure to observe or perform is not caused by the acts or omissions of any of the other Parties which constitutes a breach of this Agreement, and (ii) the defaulting Party fails to cure, correct or remedy such default within thirty (30) days after the receipt of written notice thereof from any of the other Parties, describing it with reasonable specificity, unless such failure cannot with due diligence be cured within a period of thirty (30) days, in which case such failure shall not be deemed to continue if the defaulting Party proceeds promptly and with due diligence to cure the failure and uses commercially reasonable efforts to complete the curing thereof.

16. Remedies. Subject to the cure rights set forth in Section 14 above, the non-defaulting Party or Parties may take any or all of the following actions on account of an Event of Default:

a. Enforce performance of this Agreement.

b. Exercise self-help to attempt to remedy or mitigate the effect of any breach of his Agreement by the defaulting Party and recover all actual and reasonable costs and expenses, including without limitation attorney’s fees, incurred by the non-defaulting Party or Parties in connection therewith.

c. Any non-defaulting Party may exercise such other remedies as may be available at law or in equity, subject to any limitations thereon set forth in this Agreement or by Applicable Law.

17. Sales Tax Reporting. The parties agree to take all necessary steps to report, or to cause the Parcel B Parking Operator and the Campus Parking Space Operator to report, all parking sales to the Tennessee Department of Revenue, and to make appropriate distinctions between parking revenues that are related to Stadium Events and parking revenues that are unrelated to Stadium Events.

18. Entire Agreement. This Agreement constitutes the entire understanding and agreement of Metro, the Sports Authority and StadCo with respect to the subject matter hereof, and contains all of the covenants and agreements of Metro, the Sports Authority and StadCo with respect thereto. No representations, inducements, promises or agreements, oral or written, have been made by Metro, the Sports Authority or StadCo, or anyone acting on their behalf, which are not contained herein, and any prior letters of intent, agreements, promises, negotiations, or representations not expressly set forth in this Agreement are of no force or effect.

19. Amendments; Waiver; Binding Effect. The provisions of this Agreement may not be waived, altered, changed or amended, except by instrument in writing signed by all parties hereto. The terms and conditions contained in this Agreement shall apply to, inure to the benefit of, and be binding upon the parties hereto, and upon their respective successors in interest and legal representatives, subject to the limitations on assignment herein set forth.

20. Effect on Site Coordination Agreement. This Agreement is intended to supersede those provisions of the Site Coordination Agreement related to Campus parking. In the event of a conflict between the provisions of this Agreement and the Site Coordination Agreement, the provisions of this Agreement shall control.

21. Interpretation. Words of any gender used in this Agreement shall be held and construed to include any other gender, and words in the singular number shall be held to include the plural, unless the context otherwise requires. The captions contained in this Agreement are for convenience of reference only, and in no way limit or enlarge the terms and conditions of this Agreement.

22. Severability. If any clause or provisions of this Agreement is illegal, invalid or unenforceable under present or future laws, then and in that event, it is the intention of the parties hereto that the remainder of this Agreement shall not be affected thereby. It is also the intention of the parties to this Agreement that in lieu of each clause or provision of this Agreement that is illegal, invalid or unenforceable, there be added, as a part of this Agreement, a clause or provision as similar in terms to such illegal, invalid or unenforceable clause or provision as may be possible and be legal, valid and enforceable.

23. Governing Law; Venue. This Agreement shall be construed under and in accordance with the laws of the State of Tennessee without regard to conflicts of laws principles. The state courts in Davidson County, Tennessee and the federal district court located in Nashville, Tennessee shall be the exclusive place of venue with regard to any dispute arising out of this Agreement.

24. Notices. All notices required or permitted to be given under this Agreement shall be in writing and shall be sent by registered or certified mail, return receipt requested, or by a reputable national overnight courier service, postage prepaid, or by hand delivery addressed to the parties at their addresses below. Either party may by notice given as aforesaid change its address for all subsequent notices. Except where otherwise expressly provided to the contrary, notice shall be deemed given upon delivery. Notices shall be sent to the following addresses:

Metro:

The Metropolitan Government of Nashville And Davidson County  
108 Metropolitan Court House  
PO Box 196300  
Nashville, Tennessee 37219  
Attn: Mayor

with a copy to:

Director of Law  
Metropolitan Department of Law  
108 Metropolitan Court House  
PO Box 196300  
Nashville, Tennessee 37219



Sports Authority:

The Sports Authority of The Metropolitan Government  
of Nashville And Davidson County  
730 President Ronald Reagan Way, Suite 103  
Nashville, Tennessee 37210  
Attn.: Executive Director

with a copy to:

Director of Law  
Metropolitan Department of Law  
108 Metropolitan Court House  
PO Box 196300  
Nashville, Tennessee 37219

StadCo:

Tennessee Stadium, LLC  
St. Thomas Sports Park  
460 Great Circle Road  
Nashville Tennessee 37228  
ATTN: President/CEO

with a copy to:

Tennessee Stadium, LLC  
St. Thomas Sports Park  
460 Great Circle Road  
Nashville Tennessee 37228  
ATTN: Chief Operating Officer

25. Limitation on Damages. In no event shall either party ever be liable for, and each party hereby waives any and all rights to seek or obtain consequential, punitive, or exemplary damages.

26. Interest Running with the Land. During the Term, this Agreement and StadCo's rights hereunder each constitute an interest in the land that comprises the Campus (excluding any Removed Parcel), and Metro and StadCo intend that such interest be assignable in accordance with, but subject to, the terms of this Agreement. This Agreement and StadCo's rights hereunder shall be non-revocable and shall constitute an interest in real estate that runs with title to the land that comprises the Campus (excluding any Removed Parcel) and inures to the benefit of, and is binding upon, Metro, StadCo and their respective permitted successors in title and permitted assigns, subject to the terms of this Agreement.

27. Recordation.

a. This Agreement shall not be recorded, but at the request of any party hereto, the parties shall promptly execute, acknowledge and deliver to each other a memorandum of agreement in a form reasonably agreed upon by the parties (and a memorandum of modification of agreement in respect of any modification of this Agreement) sufficient for recording against all real property within the Campus, except the Initial Development Area. Such memoranda shall not be deemed to change or otherwise affect

any of the obligations or provisions of this Agreement. The legal description of the Campus, excluding the Initial Development Area, is set forth on Exhibit 4 attached hereto.

b. From time to time, at such time as (1) the Parcel B Parking Deck is substantially complete and there has been issued any certificate required by law for the occupancy thereof, or (2) any portion of the Campus Parking Spaces have been finally designated, the Parties shall enter into a memorandum, which shall be recorded against the parcel of land upon which such parking spaces are located and shall, among other matters, memorialize the fact that such parcel of land is encumbered with the obligation to provide such parking and disclose that this Agreement allocates operational responsibility, liabilities, revenue rights and expense obligations related to such parking facilities.

28. Non-Disturbance Protection. Upon (a) Metro's entering into any Mortgage for any portion of the Campus, Metro shall, (b) a Campus Developer's entering into any Mortgage for any portion of the Campus, such Campus Developer shall, or (c) the Parcel B Developer's entering into any joinder in accordance with Section 1f of this Agreement, the Parcel B Developer shall, enter into, and shall use commercially reasonable efforts to cause its Mortgagee to enter into, a written agreement providing that such Mortgagee's security interest or legal or equitable title in the portion of the Campus subject to the Mortgage is subject to this Agreement and that so long as StadCo is not in breach of its obligations under this Agreement, such Mortgagee will not disturb StadCo's use of the parking facilities located upon the Campus, such agreement to be in a form approved by StadCo, such approval not to be unreasonably withheld, conditioned or delayed.

29. Effect of Breach on Mortgagee and Right to Cure. Any Mortgage affecting any portion of the Campus shall at all times be subject and subordinate to the terms of this Agreement, and any party foreclosing any such Mortgage or acquiring title by deed in lieu of foreclosure (whether judicial or non-judicial) or trustee's sale shall acquire title subject to all of the terms and provisions of this Agreement.

a. Breach of any of the covenants or restrictions contained in this Agreement shall not defeat or render invalid the lien of any Mortgage made in good faith, but all of the foregoing provisions, restrictions, and covenants shall be binding and effective against any Person who acquires title by foreclosure (whether judicial or non-judicial) or trustee's sale or by deed in lieu of foreclosure.

b. Notwithstanding any other provision in this Agreement for notices of default, the Mortgagee of record of any Person in default hereunder shall be entitled to notice of said default simultaneously with notice to such defaulting Person, in the same manner that other notices are required to be given under this Agreement; provided, however, that said Mortgagee shall have, prior to the time of the default, expressly notified in writing, the other Person giving said notice of default of the Mortgagee's mailing address. In the event that any such notice shall be given to such Mortgagee, such Mortgagee shall have the right to cure any such default within the cure period expressly provided to the defaulting Person hereunder, or, if such default cannot be cured within such period, diligently to commence curing within such time and diligently pursue such cure to completion within sixty (60) days thereafter. Giving of any notice of default or the failure to deliver a copy to any Mortgagee shall in no event create any liability on the part of the Person so declaring a default.

**[The Remainder of this Page Intentionally Left Blank]**

This Agreement is executed to be effective for all purposes as of the date first above written.

THE METROPOLITAN GOVERNMENT OF  
NASHVILLE AND DAVIDSON COUNTY

By: \_\_\_\_\_  
Metropolitan Mayor

ATTEST:

By: \_\_\_\_\_  
Metropolitan Clerk

APPROVED AS TO FORM AND LEGALITY:

\_\_\_\_\_  
Director of Law

TENNESSEE STADIUM, LLC,  
a Delaware limited liability company

By: \_\_\_\_\_  
Name: \_\_\_\_\_  
Title: \_\_\_\_\_

**EXHIBIT 1**  
**DEFINED TERMS**

“Affiliate” shall have the meaning ascribed thereto in the Site Coordination Agreement.

“Ambush Marketing” means any attempt by another Person, without StadCo or TeamCo or one of their respective Affiliate’s consent or the NFL’s consent, to associate itself or its products or services with the Team, the NFL, or any of the NFL’s Entities, or to directly or indirectly suggest that such product or service is endorsed by or otherwise associated with the Team, StadCo, the NFL or any of the NFL Entities. Ambush Marketing shall include, but not be limited to, the unauthorized use of StadCo and TeamCo’s intellectual property; the unauthorized use of free tickets for Stadium Events in consumer prize giveaways, contests, sweepstakes or other promotions; the creation of any advertising that incorporates a theme or image that would lead a reasonable person to believe the non-sponsor advertiser is in some way associated with or has been endorsed by the Team, StadCo, the NFL, or any of the NFL’s Entities; and any other advertising, marketing, or promotion that is undertaken by an unauthorized third party and gives the public the impression that the unauthorized third party: (i) has an official association, approval or sponsorship with the with the Team, StadCo, the NFL of any of the NFL Entities, or (ii) otherwise to imply a direct or indirect association, approval, or sponsorship with the Team, StadCo, the NFL of any of the NFL Entities as a means of promoting the unauthorized third party’s business, products, or services.

“Applicable Replacement Parking Spaces Land” shall have the meaning given to such term in Section 1g hereof.

“Authority Events” shall have the meaning assigned by the Stadium Lease Agreement.

“Campus” shall have the meaning given to such term in the recitals hereof..

“Campus Developer” means one or more third-party developers engaged by Metro pursuant to one or more development agreements to perform any development, design and construction of improvements to properties within the Campus, but excluding the Parcel B Developer and the IDA Developer.

“Campus Parking Spaces” shall have the meaning given to such term in Section 2 hereof.

“Campus Required Parking” shall have the meaning given to such term in the recitals hereof.

“Casualty” shall have the meaning given to such term in Section 3e hereof.

“CCC” shall have the meaning given to such term in the recitals hereof

“Comparable NFL Facilities” means premier, first-class multipurpose, sports stadiums incorporating, at the time of initial construction or material renovation, technological innovations, environmental sustainability considerations, and other best practices in design, construction, and ultimate operations in which NFL teams regularly play their games and that are of comparable size and age, adjusted to reflect any material renovations, as the Stadium.

“Controlled StadCo Permittee” means TeamCo, the Team and any StadCo Permittee who (i) is an Affiliate of StadCo or TeamCo, (ii) is employed by StadCo or TeamCo or any Affiliate of either of

them, (iii) has a contractual relationship with StadCo, TeamCo or any Affiliate of either of them relating to StadCo's, TeamCo's or the Team's use of the Stadium, or (iv) is otherwise controlled, directly or indirectly, by StadCo, TeamCo or any Affiliate of either of them; provided, however, that, without limitation, and except as provided above, holders of Team admission tickets and other patrons at Team Games, Team Events or other events hosted by StadCo or the Team shall be presumed to be not under the control of StadCo, TeamCo or any Affiliate of either of them absent clear and convincing evidence to the contrary (and StadCo's right to eject any such ticketholder or other patron or to revoke any current or future admission ticket of such ticketholder or other patron, including any season or subscription tickets, shall not be sufficient evidence of control by StadCo, TeamCo or any Affiliate of either of them). None of the Metro Indemnified Persons, the Authority Indemnified Persons or the Parcel B Developer Indemnified Persons shall constitute a Controlled StadCo Permittee hereunder.

"COUA" shall have the meaning given to such term in the recitals hereof.

"Development Agreement" means that certain Development and Funding Agreement by and between the Sports Authority and StadCo dated on or about August 25, 2023 and providing for the development of the Stadium.

"Existing Stadium" means the existing multi-purpose outdoor stadium currently known as Nissan Stadium, which is used for hosting Team games.

"Existing Stadium Events" means Team Events and any and all other events or activities of any kind at the Existing Stadium which are permitted under the Existing Stadium Lease, excluding events hosted by the Sports Authority.

"Existing Campus Parking Spaces" shall have the meaning given to such term in Section 2 hereof.

"Existing Stadium Lease" means that certain Stadium Lease, dated as of May 14, 1996, as amended, between the Sports Authority, as lessor, and Cumberland Stadium, L.P., as lessee, related to the Existing Stadium.

"Existing Lease" means that certain Stadium Lease, dated as of May 14, 1996, as amended, between the Authority, as lessor, and Cumberland Stadium, L.P., as lessee.

"Facility-Wide Capital Repairs" means capital repair work that relates to the Structure or Systems or is not specific to the Parcel B Parking Deck and generally affects both the Parcel B Parking Deck and another portion of the Larger Facility.

"Force Majeure" shall mean the occurrence of any of the following, for the period of time, if any, that the performance of a Party's material obligations under this Agreement is actually, materially, and reasonably delayed or prevented thereby: fire or other casualty, act of God, earthquake, flood, landslide, war, riot, civil commotion, terrorism.

"IDA Developer" shall have the meaning given to such term in the recitals hereof.

"IDA Development Agreement" shall have the meaning given to such term in the recitals hereof.

"IDA Ground Lease" shall have the meaning given to such term in the recitals hereof.

“IDA Ground Tenant” means, with respect to each IDA Ground Lease, the applicable tenant or tenants under such IDA Ground Lease, collectively or individually as the context suggests or requires.

“Initial Development Area” shall mean the land described as such on Exhibit 2 attached hereto.

“Larger Facility” shall have the meaning given to such term in Section 1f hereof.

“Loss” shall have the meaning given to such term in Section 10d.

“Metropolitan Government Indemnified Persons” shall mean the Metropolitan Council of Metro and Metro’s officers, agents, staff and employees.

“Mortgage” shall mean each mortgage, deed of trust, deed to secure debt or any other security interest in any portion of the Campus, including a collateral assignment of a leasehold interest therein.

“Mortgagee” shall mean each mortgagee, noteholder, trustee or other holder of any security interest under a Mortgage, including a collateral assignment of a leasehold interest therein.

“Negative Advertising” means mentioning Persons that are competitive with other Persons by name or by overt reference in any advertising that is visible or audible at the Stadium or the Second Street Plaza during Stadium Events.

“NFL” shall mean the National Football League.

“NFL Season” shall mean a period of time coextensive with the NFL season, including post-season, as established from time to time under the NFL rules and regulations.

“Parcel B” shall have the meaning ascribed in Section 1.

“Parcel B Developer” means any entity that Metro enters into a ground lease for the development of all or any portion of Parcel B.

“Parcel B Developer Indemnified Persons” shall mean the Parcel B Developer and the Parcel B Developer’s directors, officers, agents, staff and employees.

“Parcel B Parking Deck” shall have the meaning ascribed in Section 1.

“Parcel B Parking Deck Contractor” shall mean the Person(s) who is(are) the counterparty(ies) to one or more agreements with the Parcel B Developer to perform any development, design and construction of the Parcel B Parking Deck.

“Parcel B Parking Deck Plans” shall have the meaning given to such term in Section 1f.

“Parcel B Parking Operator” shall have the meaning given to such term in Section 5a.

“Parcel B Parking Spaces” shall have the meaning ascribed in Section 1.

“Parcel B Replacement Parking Spaces” shall have the meaning ascribed in Section 1.

“Parcel B Staging Area” shall have the meaning ascribed in Section 1.

“Party” means any party to this Agreement.

“Person” or “Persons” shall mean any individual, corporation, partnership, joint venture, association, joint stock company, trust, limited liability company, unincorporated organization, governmental authority or any other form of entity.

“Related Party(ies)” shall mean with respect to any Person, such Person’s partners, directors, board members, officers, shareholders, members, agents, employees, auditors, advisors, consultants, counsel, contractors, subcontractors (of any tier), licensees, invitees, subtenants, lenders, successors, assigns, legal representatives, elected and appointed officials, volunteers, and Affiliates, and for each of the foregoing their respective partners, directors, board members, officers, shareholders, members, agents, employees, auditors, advisors, counsel, consultants, contractors, subcontractors, licensees, invitees, and subtenants. For the avoidance of doubt, Related Parties of the Sports Authority shall not include StadCo and its Related Parties and vice versa.

“Removed Parcel” shall have the meaning given to such term in Section 2c.

“Site Coordination Agreement” shall have the meaning given to such term in the recitals hereof.

“Special Stadium Events” shall mean Stadium Events at the Stadium such as Super Bowls, NCAA tournaments, and such other similar events that may require special accommodations, such as extended hours of operation, additional seating capacity, accommodation for media coverage, etc.

“Sports Authority” shall have the meaning given to such term in the recitals hereof.

“StadCo” means Tennessee Stadium, LLC, a Delaware limited liability company.

“StadCo Permittee” means all direct and indirect tenants and subtenants of StadCo, including, without limitation, TeamCo and the Team, and the officers, directors, employees, agents, representatives, contractors, customers, vendors, suppliers, visitors, invitees, guests, licensees and concessionaires of StadCo and such tenants and subtenants thereof. None of the Metro Indemnified Persons, the Authority Indemnified Persons nor the Parcel B Developer Indemnified Persons shall constitute a StadCo Permittee hereunder. Persons engaged in civic, public or political activities, including, but not limited to, the activities set forth below, unless such Persons have been authorized to do so by StadCo or TeamCo, shall not be considered StadCo Permittees:

- (a) Exhibiting any placard, sign or notice;
- (b) Distributing any circular, handbill, placard or booklet;
- (c) Soliciting memberships or contributions for private, civic, public or charitable purposes;
- (d) Parading, picketing or demonstrating; and
- (e) Persons engaged in civic, public or political activities within the Campus.

“StadCo’s Pro Rata Share” shall have the meaning given to such term in Section 7c.

“StadCo Related Party” shall have the meaning ascribed thereto in the Site Coordination Agreement.

“Stadium” shall have the meaning given to such term in the recitals hereof.

“Stadium Event Operational Period” shall mean the period that is thirty-six (36) hours (or such reasonable lesser time as is feasible under the relevant circumstances) prior to the commencement of a Stadium Event and twenty-four (24) hours (or such reasonable lesser time as is feasible under the relevant circumstances) after the end of a Stadium Event, except for a Special Stadium Event which shall be a period that is subject to mutual agreement by the Parties.

“Stadium Event Parking Periods” shall mean the period that is six (6) hours prior to the commencement of a Stadium Event (or an Existing Stadium Event) and four (4) hours after the end of a Stadium Event (or an Existing Stadium Event), except for a Special Stadium Event, which shall be a period that is subject to mutual agreement by the Parties.

“Stadium Events” means Existing Stadium Events, Team Events, Tennessee State University football games, and any and all other events or activities of any kind at the Existing Stadium or the Stadium which are permitted under the Existing Stadium Lease or the Stadium Lease Agreement, as applicable, excluding Authority Events, in each case where tickets to such event are marketed to more than 20,000 people.

“Stadium Lease Agreement” shall mean the Stadium Lease Agreement dated as of August 25, 2023 between the Sports Authority, as lessor, and StadCo, as lessee, with respect to the Stadium, as the same may be amended, supplemented, modified, renewed or extended from time to time as provided therein.

“Stadium Project Budget” shall have the meaning ascribed to such term in the Site Coordination Agreement.

“Stadium Project Improvements” shall mean the Stadium (including all Stadium-related furniture, fixtures and equipment and all concession improvements) and all improvements appurtenant thereto or comprising a part of any of the same and all appurtenances and amenities relating to any of the same.

“Stadium Project Improvements Work” shall mean the design, development, construction, and furnishing of the Stadium Project Improvements in accordance with the Development Agreement and any demolition work in connection therewith.

“Substantial Completion” shall (i) when referring to the Stadium, have the meaning ascribed thereto in the Development Agreement, and (ii) when referring to the Parcel B Parking Deck, mean the date on which the Parcel B Parking Deck is sufficiently complete so that StadCo can use the Parcel B Parking Deck for its intended purposes, including without limitation issuance of a certificate of occupancy (temporary or final).

“Structure or Systems” means the structure of, or the mechanical, electrical, life safety or plumbing systems of, the Larger Facility.

“Team” shall mean the NFL franchise currently known as the Tennessee Titans.

“TeamCo” shall mean Tennessee Football, LLC, a Delaware limited liability company.



“Team Events” shall mean Team Games and all other events at the Stadium that are related to the football operations of the Team or the marketing or promotion of the Team.

“Team Games” shall mean each pre-season, regular season and play-off NFL game of the Team in which the Team is designated by the NFL as the “home” team, excluding any Super Bowl, even if held at the Stadium.

**EXHIBIT 2**

**INITIAL DEVELOPMENT AREA**



### EXHIBIT 3

Lot Name	# Spaces	Stadium Village	Existing Stadium	Campus Balance
Skinny A	576	576		
Lot A	1271	1271		
Lot B	1195	1195		
Lot C	441	441		
Lot D	410	410		
Lot E	374			374
Lot F	481			481
Lot G	213			213
Lot H	295		295	
Lot J	69		69	
Lot K	64		64	
Lot M	283			283
Lot N	507			507
Lot P	52			52
Lot R	879			879
Lot S	175		175	
Lot T	210			210
	7495	3893	603	2999
Net		3602	2999	



**EXHIBIT 4**

**LEGAL DESCRIPTION OF CAMPUS, EXCLUDING INITIAL DEVELOPMENT AREA**

[to be attached when Campus survey is complete]

37375825.3

**FIRST AMENDED AND RESTATED  
SITE COORDINATION AGREEMENT**

**by and between**

**THE METROPOLITAN GOVERNMENT OF NASHVILLE AND DAVIDSON COUNTY**

**and**

**TENNESSEE STADIUM, LLC**

**Dated as of \_\_\_\_\_, 2024**

## TABLE OF CONTENTS

ARTICLE 1 GENERAL TERMS.....	4
Section 1.1    Definitions and Usage.....	4
Section 1.2    Campus Developer Joinder and Assumption.....	4
Section 1.3    Campus Developer Obligations.....	4
Section 1.4    Metro Obligations.....	4
ARTICLE 2 REPRESENTATIVES OF THE PARTIES.....	4
Section 2.1    Metro Representatives.....	4
Section 2.2    StadCo Representative.....	4
ARTICLE 3 TERM.....	5
Section 3.1    Term.....	5
ARTICLE 4 REPRESENTATIONS.....	5
Section 4.1    Representations and Warranties of Metro.....	5
Section 4.2    Representations and Warranties of StadCo.....	6
ARTICLE 5 CONSTRUCTION DEVELOPMENT AND COORDINATION.....	7
Section 5.1    Development of Campus Improvements.....	7
Section 5.2    Campus Improvements Design and Construction Coordination.....	7
Section 5.3    Performance of the Campus Improvements Work.....	8
Section 5.4    General Coordination Obligations.....	8
Section 5.5    Access to the Project.....	10
Section 5.6    Stadium Events.....	10
Section 5.7    General Cooperation.....	10
Section 5.8    Environmental Remediation.....	10
Section 5.9    Contract Requirements.....	11
ARTICLE 6 CAPITAL IMPROVEMENTS NECESSARY TO THE OPERATION OF THE STADIUM.....	11
Section 6.1    Parking.....	11
Section 6.2    Development, Operation and Maintenance of Second Street Plaza.....	11
Section 6.3    Second Street and Adjacent Sidewalks.....	11
Section 6.4    Campus Park.....	11
Section 6.5    Funding as Eligible Project Expenses.....	12
ARTICLE 7 COVENANTS, CONDITIONS AND RESTRICTIONS.....	12
Section 7.1    General.....	12
Section 7.2    Easements.....	12
Section 7.3    Operation and Maintenance.....	13
Section 7.4    Use Restrictions.....	13
Section 7.5    Additional Reserved Rights.....	14
ARTICLE 8 Campus use and operation.....	14
Section 8.1    Campus Park.....	14
Section 8.2    Special Stadium Events.....	14

Section 8.3	License .....	14
Section 8.4	Commercial Matters .....	15
ARTICLE 9	INSURANCE AND INDEMNITY .....	17
Section 9.1	Policies Required for Stadium Project Improvements Work .....	17
Section 9.2	Indemnity .....	17
Section 9.3	Waiver of Right of Recovery.....	17
Section 9.4	Indirect, Special, Exemplary or Consequential Damages .....	18
ARTICLE 10	DEFAULTS AND REMEDIES.....	18
Section 10.1	Events of Default and Remedies.....	18
ARTICLE 11	STANDARDS FOR APPROVALS .....	19
Section 11.1	Review and Approval Rights.....	19
Section 11.2	Standard for Review .....	19
Section 11.3	Resubmissions .....	20
Section 11.4	Duties, Obligations, and Responsibilities Not Affected.....	20
ARTICLE 12	DISPUTE RESOLUTION .....	20
Section 12.1	Settlement By Mutual Agreement .....	20
ARTICLE 13	EFFECT OF IDA COORDINATION AGREEMENTS .....	21
Section 13.1	Exclusion of the Initial Development Area .....	21
Section 13.2	Application to Future Development Area.....	21
Section 13.3	Removal of Campus Property from the Initial Development Area .....	22
ARTICLE 14	MISCELLANEOUS PROVISIONS.....	22
Section 14.1	Notices .....	22
Section 14.2	Amendment.....	23
Section 14.3	Waivers.....	23
Section 14.4	Counterparts.....	23
Section 14.5	Knowledge.....	23
Section 14.6	Drafting.....	23
Section 14.7	No Third-Party Beneficiaries.....	23
Section 14.8	Entire Understanding.....	24
Section 14.9	Termination Upon Termination of Stadium Development Agreement.....	24
Section 14.10	Governing Law, Venue; Waiver of Jury.....	24
Section 14.11	Time is of the Essence .....	25
Section 14.12	Severability .....	25
Section 14.13	Relationship of the Parties .....	25
Section 14.14	Further Assurances/Additional Documents and Approval.....	25
Section 14.15	Recording.....	26
Section 14.16	Estoppel Certificate .....	26
Section 14.17	No Personal Liability to Representatives and Owners .....	26
Section 14.18	Runs with the Land.....	26
Section 14.19	Prohibition Against Boycotting Israel. ....	26
Section 14.20	Public Records .....	26
Section 14.21	Permitted Assignment by Metro.....	27

EXHIBITS:

EXHIBIT A:	Glossary of Defined Terms and Rules of Usage
EXHIBIT B:	Campus Property
EXHIBIT C:	Stadium Site
EXHIBIT D:	Existing Stadium Site
EXHIBIT E:	Initial Development Area
EXHIBIT F:	Approximate Size and Location of Campus Park
EXHIBIT G:	Depiction of Second Street Plaza



## FIRST AMENDED AND RESTATED SITE COORDINATION AGREEMENT

THIS FIRST AMENDED AND RESTATED SITE COORDINATION AGREEMENT (this “Agreement”) is made as of \_\_\_\_\_, 2024 (the “Effective Date”), by and between THE METROPOLITAN GOVERNMENT OF NASHVILLE AND DAVIDSON COUNTY (“Metro” or the “Metropolitan Government”) and TENNESSEE STADIUM, LLC, a Delaware limited liability company (“StadCo”). Metro and StadCo collectively are referred to herein as the “Parties” and individually as a “Party.”

### RECITALS

WHEREAS, The Sports Authority of The Metropolitan Government of Nashville and Davidson County (the “Sports Authority”) owned approximately 95-acres of property located on the East Bank along the Cumberland River (the “Campus”), as described in **Exhibit B**;

WHEREAS, the entirety of the Campus was previously leased by the Sports Authority to Cumberland Stadium, Inc., a Delaware corporation and successor to Cumberland Stadium, LP, a Tennessee limited partnership (“Cumberland”), an affiliate of StadCo and the National Football League’s (the “NFL’s”) Tennessee Titans, operating as Tennessee Football, LLC (the “Team”), pursuant to that certain Stadium Lease, dated as of May 14, 1996, as amended, between the Sports Authority, as lessor, and Cumberland, as lessee (the “Existing Stadium Lease”), and the Campus is the home to a multi-purpose outdoor stadium currently known as Nissan Stadium (the “Existing Stadium”) and surface parking for the Existing Stadium;

WHEREAS, the Metropolitan Government, the Sports Authority and the Team have determined that the construction of a new, first-class, state-of-the-art, enclosed venue for professional football and numerous other sporting, entertainment, cultural and civic events, and which will be used for hosting Team games (the “Stadium”) will encourage and foster economic development and prosperity for Metro and the State of Tennessee;

WHEREAS, the parties have agreed that the Stadium will be located on an approximately 20-acre portion of property located on the Campus immediately to the east of the Existing Stadium, as generally depicted and more specifically defined in **Exhibit C** (the “Stadium Site”), and that the Existing Stadium will continue to remain in operation until the Stadium commences operations, at which point the Existing Stadium will be demolished;

WHEREAS, the parties have determined that the Metropolitan Government should arrange for the development of those portions of the Campus located outside of the Stadium Site, including the location of the Existing Stadium after its demolition, all as more fully described herein;

WHEREAS, to facilitate the foregoing, (i) the Sports Authority and Cumberland have further amended the Existing Stadium Lease to reduce the leased premises subject thereto to that property described in **Exhibit D** (the “Existing Stadium Site”); (ii) the Sports Authority has conveyed fee title to the entirety of the Campus, other than the Existing Stadium Site, to Metro; and (iii) the Sports Authority has granted Metro an option to purchase the Existing Stadium Site upon the expiration of the Existing Stadium Lease, all such that the Metropolitan Government will ultimately hold fee title to the entirety of the Campus;

WHEREAS, Metro and the Sports Authority have entered into that certain Ground Lease dated as of August 25, 2023, whereby Metro, as lessor, will ground lease the Stadium Site to the Sports Authority, as lessee;

WHEREAS, the Sports Authority and StadCo, have entered into that certain Development and Funding Agreement dated as of August 25, 2023 (the “Stadium Development Agreement”), providing for the financing, development and construction of the Stadium on the Stadium Site, and the rights and responsibilities of the Sports Authority and StadCo related thereto;

WHEREAS, the Sports Authority and StadCo have entered into that certain Stadium Lease Agreement dated as of August 25, 2023 (the “Stadium Lease”), providing for the lease of the Stadium, once completed, by the Sports Authority, as sublessor, to StadCo, as sublessee, and including matters relating to the use, occupancy, operation, maintenance and repair of the Stadium and certain other matters collateral thereto;

WHEREAS, Metro, StadCo and the Sports Authority entered into that certain Site Coordination Agreement dated August 25, 2023 (the “Original SCA”) to set forth certain agreements with respect to (i) the provision and maintenance of parking facilities for the benefit of the Stadium and, while it remains in operation, the Existing Stadium, (iii) the development, design, construction and operation of the Campus at the direction of Metro, and the coordination thereof with Stadium Project Improvements Work, and (ii) the respective rights and obligations of Metro, the Sports Authority and StadCo with respect to the use and operation of the Campus;

WHEREAS, the Original SCA contemplated that Metro could (i) engage one or more third-party developers (each a “Campus Developer”) pursuant to one or more development agreements, long-term ground leases and/or other definitive agreements (each, a “Campus Development Agreement”) to perform development, design and construction of improvements to properties within the Campus, including any Campus Improvements, as defined herein, and (ii) cause each such Campus Developer to execute a joinder agreement relating to all obligations of a Campus Developer under the Original SCA, whereupon Metro would be released from any and all obligations assumed by such Campus Developer;

WHEREAS, Metro has engaged TFC Nashville Development LLC, a Delaware limited liability company (the “IDA Developer”) pursuant to that certain Master Development Agreement dated as of \_\_\_\_\_, 2024 (the “IDA Development Agreement”), under which Metro will enter into one or more long-term ground leases (each, as it may be amended from time to time in accordance with its terms, an “IDA Ground Lease”) with one or more ground lessees (each, an “IDA Ground Tenant”) to provide for the development of those portions of the Campus identified on **Exhibit E** (the “Initial Development Area”);

WHEREAS, within the Initial Development Area, the parcel identified on **Exhibit E** as Parcel B may be referred to herein as “Development Parcel B”, and the parcel identified on **Exhibit E** as Parcel C may be referred to herein as the “Development Parcel C” (Development Parcels B and C, collectively, the “Stadium-Adjacent Parcels”);

WHEREAS, adjacent to the Stadium Site and Development Parcel C, there is an area that may hereafter be described as the “Second Street Plaza Site”, as further defined in **Exhibit A** and depicted on **Exhibit G**, on which StadCo will design, develop, construct, operate and maintain an open-space plaza (the “Second Street Plaza”) as part of the Project Improvements Work;

WHEREAS, Metro has executed and recorded that certain Declaration of Easements, Restrictions and Covenants for Parcel B, the Stadium Plaza and Parcel C, East Bank dated as of \_\_\_\_\_, 2024 and applicable to Development Parcel B and Parcel C, including the Second Street Plaza Site (the “Declaration”);

WHEREAS, Metro intends to develop the portion of the Campus not included in the Stadium Site or Initial Development Area, whether as a result of such portions not originally being included in the Initial Development Area or such portions being subsequently removed from the Initial Development Area (the “Future Development Area”) via Campus Development Agreements with one or more Campus Developers;

WHEREAS, to set forth certain agreements regarding the respective rights and obligations of Metro, StadCo and the IDA Developer relative to the design, development, construction, operation, maintenance and use of the properties within the Initial Development Area, and in lieu of IDA Developer executing a joinder to the Original SCA, Metro, StadCo and IDA Developer have entered into that certain Campus Operations and Use Agreement dated as of even date herewith, which provides that the IDA Developer and StadCo will enter into an agreement to coordinate the construction of the Initial Development Area with the Stadium (the “Construction Management Agreement”) (together with the Declaration, the “IDA Coordination Agreements”);

WHEREAS, Metro and StadCo have executed that one certain Stadium Parking License and Operations Agreement dated as of even date herewith (the “Parking Agreement”);

WHEREAS, the Sports Authority was a party to the Original SCA, but the Parties and the Sports Authority have determined that, given the absence of any foreseeable Sports Authority responsibilities under the Original SCA or this Agreement, it is appropriate to remove the Sports Authority as a party to better clarify that the Sports Authority shall have no liabilities under the Original SCA or hereunder; and the Sports Authority has provided its written acknowledgement and agreement to its removal from the Original SCA; and

WHEREAS, Metro and StadCo are executing and entering into this Agreement in light of the foregoing, and to set forth certain agreements with respect to (i) the development, design, construction and operation of the Campus at the direction of the Metropolitan Government, and the coordination thereof with Stadium Project Improvements Work, and (ii) the Parties’ respective rights and obligations with respect to the use and operation of the Campus;

NOW, THEREFORE, in consideration of the foregoing Recitals, which are hereby incorporated into this Agreement, and the mutual premises, undertakings, and covenants hereinafter set forth, and intending to be legally bound hereby, the Parties agree as follows:

## AGREEMENT

### ARTICLE 1 GENERAL TERMS

Section 1.1 Definitions and Usage. Capitalized terms used in this Agreement shall have the meanings assigned to them in Exhibit A, which also contains rules as to usage applicable to this Agreement, or within the individual sections of this Agreement.

Section 1.2 Campus Developer Joinder and Assumption. Subject to Section 1.4 of this Agreement, until Metro causes a Campus Developer or Developers to execute a joinder agreement relating to all obligations of a Campus Developer hereunder (such agreement to be reasonably agreed between Metro and StadCo), Metro shall be liable for all obligations of a Campus Developer pursuant to the terms of this Agreement that must be performed before such date or dates. Following the execution of a joinder by a Campus Developer, Metro shall be released from any and all obligations assumed by a Campus Developer. The provisions of this Section 1.2 are subject to the provisions of Article 13.

Section 1.3 Campus Developer Obligations. To the extent there are multiple Campus Developers performing the obligations of a “Campus Developer” under this Agreement, the phrase “the Campus Developer” or “a Campus Developer” shall mean and refer to each such Campus Developer with respect to the portion of the Campus that it is to develop, and multiple Campus Developers shall not be jointly and severally liable unless expressly so stated.

Section 1.4 Metro Obligations. To the extent, if any, Metro undertakes, or is required to undertake, for any reason one or more obligations of the Campus Developer described in this Agreement, the corresponding reference herein to the Campus Developer shall be construed to refer to Metro, and Metro shall be obligated to perform such obligation with respect to the applicable component of the Campus to which such obligation pertains until a Campus Developer assumes such obligations.

### ARTICLE 2 REPRESENTATIVES OF THE PARTIES

Section 2.1 Metro Representatives. Metro hereby designates the Metropolitan Mayor, or such other persons as he or she may designate in writing from time to time, to be Metro’s authorized representative pursuant to this Agreement (the “Metro Representative”). Any written Approval, decision, confirmation or determination of the Metro Representative shall be binding on Metro, except in those instances in which this Agreement specifically provides for the Approval, decision, confirmation or determination of the Metropolitan Council.

Section 2.2 StadCo Representative. StadCo hereby designates the Chief Operating Officer of StadCo to be the representative of StadCo (the “StadCo Representative”), and shall have the right, from time to time, to change the individual who is the StadCo Representative by giving at least ten (10) days’ prior written Notice to the other Parties thereof. With respect to any action, decision or determination to be taken or made by StadCo under this Agreement, the StadCo Representative shall take such action or make such decision or determination or shall notify the other Parties in writing of the Person(s) responsible for such action, decision or determination and

shall forward any communications and documentation to such Person(s) for response or action. Any written Approval, decision, confirmation or determination hereunder by the StadCo Representative shall be binding on StadCo; *provided, however*, that notwithstanding anything in this Agreement to the contrary, the StadCo Representative shall not have any right to modify, amend or terminate this Agreement.

### **ARTICLE 3 TERM**

Section 3.1 Term. The term of this Agreement shall commence on the Effective Date and, except as otherwise expressly provided herein, shall expire at the end of the Lease Term (the “SCA Term”). Notwithstanding the expiration of the Lease Term or the earlier termination of this Agreement, these rights and obligations of the Parties herein that are expressly intended to survive such expiration or earlier termination shall accordingly survive.

### **ARTICLE 4 REPRESENTATIONS**

Section 4.1 Representations and Warranties of Metro. Metro represents and warrants to StadCo, as of the Effective Date (unless otherwise expressly provided herein) and thereafter until this Agreement expires or is terminated, as follows:

(a) Organization. Metro is a public corporation established by Charter adopted by referendum vote on June 28, 1962, in conformity with the laws of the State.

(b) Authorization. Metro has the full right, power, and authority to execute and deliver this Agreement and to perform and satisfy its obligations and duties hereunder. The execution, delivery, and performance of this Agreement by Metro have been duly and fully authorized and approved by all necessary and appropriate action, and a true, complete, and certified copies of the authorizing legislation have been delivered to StadCo. This Agreement has been duly executed and delivered by Metro, and the individuals executing and delivering this Agreement on behalf of Metro have all requisite power and authority to execute and deliver the same and to bind Metro hereunder.

(c) Binding Obligation and Enforcement. Assuming execution of this Agreement by StadCo, this Agreement constitutes legal, valid, and binding obligations of Metro, enforceable against Metro in accordance with its terms.

(d) Governing Documents. The execution, delivery, and performance of this Agreement by Metro does not and will not result in or cause a violation or breach of, or conflict with, any provision of Metro’s governing documents or rules, policies or regulations applicable to Metro.

(e) Law. The execution, delivery, and performance of this Agreement by Metro does not and will not result in or cause a violation or breach of, or conflict with, Applicable Laws applicable to Metro or any of its respective properties or assets which will have a material adverse effect on Metro’s ability to perform and satisfy its obligations and duties hereunder. All

actions and determinations required to be taken or made by Metro prior to the Effective Date have been taken or made.

(f) Contracts; No Conflict. The execution, delivery, and performance of this Agreement by Metro does not and will not result in or cause a violation or breach of, conflict with, constitute a default under, require any consent, approval, waiver, amendment, authorization, notice or filing under any agreement, contract, understanding, instrument, mortgage, lease, indenture, document or other obligation to which Metro is a party or by which Metro or any of its properties or assets are bound which will have a material adverse effect on Metro's ability to perform and satisfy its obligations and duties hereunder.

(g) Absence of Litigation. There is no action, suit, proceeding, claim, arbitration or investigation pending or, to Metro's knowledge, threatened by any Person, against Metro or its assets or properties which if unfavorably determined against Metro would have a material adverse effect on Metro's ability to perform and satisfy its obligations and duties hereunder.

Section 4.2 Representations and Warranties of StadCo. StadCo represents and warrants to Metro, as of the Effective Date (unless otherwise expressly provided herein), as follows:

(a) Organization. StadCo is a Delaware limited liability company duly organized, validly existing, and in good standing under the laws of the State of Delaware and duly authorized to do business in the State of Tennessee. StadCo possesses full and adequate power and authority to own, operate, and lease its properties, and to carry on and conduct its business as it is currently being conducted.

(b) Authorization. StadCo has the full right, power, and authority to execute and deliver this Agreement and to perform and satisfy its obligations and duties hereunder. The execution, delivery, and performance of this Agreement by StadCo have been duly and fully authorized and approved by all necessary and appropriate action, and a true, complete, and certified copy of the authorizing resolutions has been delivered to Metro. This Agreement has been duly executed and delivered by StadCo. The individual executing and delivering this Agreement on behalf of StadCo has all requisite power and authority to execute and deliver the same and to bind StadCo hereunder.

(c) Binding Obligation and Enforcement. Assuming execution of this Agreement by Metro, this Agreement constitutes legal, valid, and binding obligations of StadCo, enforceable against it in accordance with its terms.

(d) Governing Documents. The execution, delivery, and performance of this Agreement by StadCo does not and will not result in or cause a violation or breach of, or conflict with, any provision of its articles of organization, operating agreement or other governing documents, or the NFL Rules and Regulations.

(e) Law. The execution, delivery, and performance of this Agreement by StadCo does not and will not result in or cause a violation or breach of, or conflict with, any Applicable Laws applicable to StadCo or any of its properties or assets which will have a material adverse effect on the ability of StadCo to perform and satisfy its obligations and duties hereunder.

All actions and determinations required to be taken or made by StadCo prior to the Effective Date have been taken or made.

(f) Contracts; No Conflict. The execution, delivery, and performance of this Agreement by StadCo does not and will not result in or cause a termination, modification, cancellation, violation or breach of, conflict with, constitute a default under, result in the acceleration of, create in any party the right to accelerate, require any consent, approval, waiver, amendment, authorization, notice or filing under any agreement, contract, understanding, instrument, mortgage, lease, sublease, license, sublicense, franchise, permit, indenture, agreement, mortgage for borrowed money, instrument of indebtedness, security instrument, indenture, document or other obligation to which StadCo is a party or by which StadCo or any of its properties or assets are bound.

(g) Absence of Litigation. There is no action, suit, proceeding, claim, arbitration or investigation pending or, to the knowledge of StadCo, threatened by any Person, against StadCo or its assets or properties that questions the validity of this Agreement or the transactions contemplated herein or which, individually or collectively, if unfavorably determined would have a material adverse effect on the assets, conditions, affairs or prospects of StadCo, financially or otherwise, including the ability of StadCo to perform and satisfy its obligations and duties hereunder.

## **ARTICLE 5 CONSTRUCTION DEVELOPMENT AND COORDINATION**

Section 5.1 Development of Campus Improvements. The Metropolitan Government may, but shall not be required to, engage one or more Campus Developers pursuant to one or more Campus Development Agreements to perform any development, design and construction of improvements to properties within the Campus, including any Campus Infrastructure (but specifically excluding the Stadium Project Improvements Work) (“Campus Improvements”), provided that any such development, design and construction shall be subject to the terms of this Agreement. Any work undertaken by or on behalf of the Metropolitan Government by a Campus Developer to develop, design and construct Campus Improvements (the “Campus Improvements Work”), shall be undertaken at no cost to StadCo except as otherwise expressly set forth herein. For the avoidance of doubt, subject to Section 5.2(a), the Campus Developer shall have sole approval rights over its final design documents of the Campus Improvements Work.

### Section 5.2 Campus Improvements Design and Construction Coordination.

(a) Campus Improvements Plan Review Coordination. The Metropolitan Government agrees to include within each Campus Development Agreement a requirement that the Campus Developer identified thereunder (i) meet and consult with StadCo as part of a collaborative process to allow StadCo to review and provide input with respect to the development and design of the Campus Improvements and in particular the development and design of the Stadium-Adjacent Parcels (if applicable), (ii) consider, in good faith, any opinions and observations StadCo may have with respect thereto, and (iii) endeavor, in good faith, to consult with StadCo at such reasonable times prior to finalization of the various stages of the Campus Improvements design documents by the Campus Developer so that StadCo has adequate time to

provide coordinated input, provided that in no event is the Campus Developer required to delay the design schedule to allow for StadCo review and input. The Parties acknowledge that the purpose of this paragraph is to allow StadCo to review, consult and provide input with regard to various elements of the Campus Improvements design in an effort to coordinate continuity and shared interests as between the Project Improvements and the Campus Improvements.

(b) Campus Improvements Work. The Metropolitan Government agrees to include within each Campus Development Agreement a requirement that the Campus Developer identified thereunder (i) keep StadCo reasonably informed as part of a collaborative process with respect to the Campus Improvements Work, and material modifications thereto, and in particular any Campus Improvements Work occurring on the Stadium-Adjacent Parcels, if applicable (the “Stadium-Adjacent Parcels Improvements Work”), and (ii) meet with the StadCo Representative at time reasonably requested by the StadCo Representative to advise StadCo regarding the status of the Campus Improvements Work. The StadCo Representative shall provide the Campus Developer with its opinions and suggestions related to the Campus Improvements Work with reasonable promptness. The Campus Developer agrees to consider and review opinions and suggestions submitted by the StadCo Representative.

(c) Project Improvements Work. StadCo agrees to include within the Construction Manager at Risk Agreement a requirement that the CMAR (i) keep the Campus Developers reasonably informed as part of a collaborative process with respect to the Campus Improvements Work, and material modifications thereto, and in particular any Stadium-Adjacent Parcels Improvements Work occurring on the Stadium-Adjacent Parcels, and (ii) meet with the Campus Developers at times reasonably requested by a Campus Developer to advise the Campus Developer regarding the status of the Project Improvements Work.

Section 5.3 Performance of the Campus Improvements Work. Except as expressly provided in this Agreement, the Metropolitan Government, or the Campus Developer on its behalf, is responsible for all costs incurred in connection with the Campus Improvements Work, including any costs, charges and fees in connection with supplying the Campus Improvements with all necessary utilities, all costs, charges, and fees payable to any Governmental Authority in connection with the Campus Improvements Work (including all building permits, platting, and zoning fees and street closure fees or any other license, permit or approval under Applicable Laws), and all other site preparation costs, fees or expenses incurred in connection with the design, development, construction, furnishing, and opening of the Campus Improvements. For the avoidance of doubt, neither the Metropolitan Government nor any Campus Developer is responsible for Infrastructure Work or any costs, charges, and fees payable to any Governmental Authority in connection with the Project Improvements Work (including all building permits, platting, and zoning fees and street closure fees or any other license, permit or approval under Applicable Laws), and all other site preparation costs, fees or expenses incurred in connection with the design, development, construction, furnishing, and opening of the Project Improvements.

Section 5.4 General Coordination Obligations. The Metropolitan Government agrees to include within each Campus Development Agreement a requirement that, until the Substantial Completion of the Stadium Project Improvements Work, the Campus Developer and any Campus Contractor identified thereunder, shall comply with the obligations assigned to them below. Likewise, StadCo agrees to include in the Construction Manager at Risk Agreement a requirement



that, until the Substantial Completion of the Stadium Project Improvements Work, the CMAR shall comply with the obligations assigned to it below.

(a) Schedule Coordination. The Campus Developers, Campus Contractors, StadCo and the CMAR shall meet and confer in good faith as required to coordinate construction schedules for the Campus Improvements Work with the construction schedules for the Stadium Project Improvements Work to avoid delays or interference. The Campus Developer and Campus Contractor on the one hand, and StadCo and the CMAR on the other hand, (i) shall meet and confer in good faith from time to time to provide each other with monthly construction schedule updates to extent their work has continuing, potential impacts with respect to delay or interference, and (ii) agree to work in good faith with respect to such schedule coordination. However, the Metropolitan Government shall cause each Campus Developer and any Campus Contractor to agree that any construction work of a material nature that is likely to affect the critical path that is required to achieve Substantial Completion (as that term is defined in the Stadium Lease) of Project Improvements shall take precedence with respect to coordination of schedules. At the first meeting with a Campus Developer, StadCo shall provide to such Campus Developer a construction schedule for the Stadium Project Improvements Work, and prior to commencing construction of any new Campus Improvements within the Stadium-Adjacent Parcels, the Metropolitan Government shall cause each Campus Developer and any Campus Contractor to provide to StadCo with a Campus Improvements Construction Schedule with respect thereto.

(b) Site Management Plan Coordination. The Campus Developers, Campus Contractors, StadCo, and the CMAR shall meet and confer in good faith to coordinate site management plans with respect to the Campus Improvements Work and the Stadium Project Improvements Work. However, the Campus Developers agree that, given the criticality of timing with respect to Stadium opening and the CMAR's compliance with sequencing and schedules in order to accommodate that objective, the Campus Developers shall (and shall cause any Campus Contractors to) give reasonable deference to the CMAR's site management plan as it pertains to necessary site access, parking, staging and storage, including lay down space, crane operations and other construction-related activities, provided that all parties agree to work in good faith to resolve any disputed issues with respect thereto that may arise. In addition, given the tight boundary constraints of the Stadium Site, the Campus Developers agree (and shall cause any Campus Contractors) to coordinate in good faith to afford the CMAR reasonable opportunity for introduction, storage and/or operation of its materials and equipment and performance of its activities on the Campus as may be reasonably required in connection with the performance of the Stadium Project Improvements Work. Once the Stadium is Substantially Complete, StadCo shall give reasonable deference to the Campus Developer's and Campus Contractors' site management plan, provided that such plan does not result in material interference with StadCo's right to use the Campus, including without limitation the Stadium, Second Street Plaza and Campus Park, during Stadium Event Operational Periods, as provided herein, or otherwise result in material interference with StadCo's operations at the Stadium or the Second Street Plaza.

(c) Safety Plan Coordination. The Campus Developer, Campus Contractor, StadCo and the CMAR shall coordinate in good faith with regard to site safety compliance and site security with respect to the Stadium Project Improvements Work and the Campus

Improvements Work, particularly with respect to parking in use by StadCo., TeamCo and their Related Parties and damage to individuals and adjacent property.

(d) Integration of Work. The Campus Developers, Campus Contractors, StadCo and the CMAR shall coordinate in good faith with respect to portions of the Campus Improvements and the Stadium Project Improvements that require integration and shall coordinate with regard to schedules, sequencing, means and methods with respect thereto.

Section 5.5 Access to the Project. StadCo and the Campus Developer shall cooperate in good faith to grant StadCo access to the Campus Improvements, at reasonable times and upon reasonable notice to the Campus Developer, to review the status of the Campus Improvements, provided that StadCo adheres to any safety protocols implemented by the Campus Developer.

Section 5.6 Stadium Events. The Campus Developer and StadCo shall coordinate in good faith to (i) develop and implement a plan to prevent material interference with Stadium Events during Stadium Event Operational Periods caused by Campus construction operations performed by the Campus Developers and any Campus Contractor, including material interference caused by dust, noise, construction traffic and such other construction activity that may have a materially negative impact on Stadium Event operations and (ii) ensure that an available pathway exists on roads, sidewalks and walkways (to the extent controlled by the Campus Developer or Metro and are otherwise in compliance with duly adopted and generally applicable regulations) from agreed upon parking areas to the Stadium Site and they are open and available for pedestrian and vehicular traffic.

Section 5.7 General Cooperation. Subject to the coordination obligations in Section 5.4, the Campus Developers and StadCo agree to cooperate in good faith with the other during the SCA Term so as to keep the other reasonably apprised of any Project Improvements Work and the Campus Improvements Work on an advisory basis and in particular with respect to the Stadium-Adjacent Parcels Improvements Work.

Section 5.8 Environmental Remediation.

(a) Campus. Metro and the Campus Developers are solely responsible for the remediation, disposal, and transport of all Hazardous Materials in connection with the Campus Improvements (i) on that portion of the Campus located outside of the Stadium Site, whether pre-existing or brought to or created on such portion of the Campus, by Metro, the Sports Authority, a Campus Developer, a Campus Contractor or their Related Parties or (ii) on the Stadium Site with respect to the migration of Hazardous Materials from the Campus located outside the Stadium Site to the Stadium Site after the date hereof to the extent caused by Metro, the Sports Authority, a Campus Developer, a Campus Contractor or their Related Parties.

(b) Stadium Site. StadCo and the CMAR are solely responsible for the remediation, disposal, and transport of all Hazardous Materials in connection with the Stadium Project Improvements (i) on the Stadium Site to the extent pre-existing or brought to or created on the Stadium Site by StadCo, the CMAR or their Related Parties or (ii) on that portion of the Campus located outside of the Stadium Site with respect to the migration of Hazardous Materials to such portion of the Campus to the extent caused by StadCo or CMAR.

Section 5.9 Contract Requirements. Metro shall require its Campus Developers to include in all contracts for the performance of any Campus Improvements Work (each a “Campus Contract” and collectively the “Campus Contracts”) to (i) name TeamCo, StadCo and their Affiliates as additional insureds as their interests may appear on all policies of liability insurance (except for workers’ compensation and professional liability) (ii) require such Person to perform the Campus Improvements Work in accordance with Applicable Law, and (iii) grant StadCo and TeamCo an irrevocable (during the Term of the Stadium Lease), non-exclusive license to those necessary portions of the Campus Improvements plans, to use them solely to facilitate StadCo’s operations on the applicable portions of the Campus as provided in this Agreement.

## ARTICLE 6

### CAPITAL IMPROVEMENTS NECESSARY TO THE OPERATION OF THE STADIUM

Section 6.1 Parking. The terms and conditions regarding the development, maintenance and operation of parking facilities for the benefit of StadCo is set forth in the Parking Agreement.

Section 6.2 Development, Operation and Maintenance of Second Street Plaza. StadCo shall be responsible for designing, developing, constructing the Second Street Plaza as part of the Stadium Project Improvements Work, pursuant to the terms and conditions of the Stadium Development Agreement. The maintenance, repair, use and operation of the Second Street Plaza will be governed by the terms and conditions of the IDA Coordination Agreements.

Section 6.3 Second Street and Adjacent Sidewalks. The portion of Second Street (and adjacent sidewalks and utilities) between Woodland Street and Shelby Street will be developed, designed and constructed on a temporary and permanent basis as part of the Project Improvements (the “Second Street Improvements”). The cost of the Second Street Improvements on both a temporary and permanent basis is included in the Stadium Project Budget. However, Metro shall cause the Sports Authority to reimburse StadCo for 50% of the portion of its costs related to developing, designing and constructing the Second Street Improvements on a permanent basis. StadCo may send Metro and the Sports Authority an invoice for such costs in the manner described in Section 9.9 of the Stadium Lease, and Metro shall cause the Sports Authority to pay such invoice from amounts on deposit in the Eligible Projects Fund in the manner described in the Stadium Lease.

Section 6.4 Campus Park. The Parties agree that a portion of the Campus in substantially the size and location within the Metropolitan Government Planning Department’s Imagine East Bank vision plan, as depicted on **Exhibit F** (the “Campus Park Area”) will consist of an open-space, park area owned by Metro or an instrumentality thereof (the “Campus Park”), to be utilized by StadCo in Stadium Event Operational Periods as more fully described herein. No Campus Improvements Work inconsistent with the reservation of the Campus Park Area shall be undertaken without the prior written consent of StadCo. The Metropolitan Government or its designee shall develop, design and construct the Campus Park at its sole cost and expense. The appropriate Metro officials shall make a good faith effort to present for approval by all necessary governing bodies the construction and funding of the design, development and construction of the Campus Park Area, as and when Campus Improvements Work is being designed, developed and constructed in the Future Development Area.

Section 6.5 Funding as Eligible Project Expenses. The Parties anticipate and agree that the capital projects described in this Article 6, including all projects for parking facilities contemplated by the Parking Agreement, constitute Eligible Projects (as defined in the Stadium Lease), which may be funded in the manner contemplated by Section 9.9 of the Stadium Lease.

## **ARTICLE 7 COVENANTS, CONDITIONS AND RESTRICTIONS**

Section 7.1 General. The Parties acknowledge and agree that the Campus shall be subject to covenants, conditions and restrictions (“CC&Rs”) described in this Article 7 established by Metro but which shall be subject to the reasonable, prior written approval of StadCo and shall be recorded in the Office of the Davidson County Register of Deeds prior to Metro’s conveyance or lease to any Campus Developer or any other third party of any interest in any of the real property described on Exhibit B attached hereto, but in any case, on or before the effective date of a lease to a Campus Developer with respect to such real property.

Section 7.2 Easements. The Parties agree that the CC&Rs shall include easement provisions as follows:

(a) Campus Park. Metro and StadCo will work together to agree upon the terms upon which Metro will establish an easement over the Campus Park for the benefit of the StadCo and its Related Parties.

(b) Access Easement. Metro will establish an easement over the portion of any open space and pedestrian access way located within the Stadium-Adjacent Parcels for the purposes of access, ingress and egress to, from and between the streets abutting and adjacent to the Stadium-Adjacent Parcels and the Stadium Site for the benefit of StadCo and its Related Parties, subject to event protocols to be determined in the CC&Rs.

(c) Utility Easements. Metro and StadCo will work together to agree upon defined easements across, through and upon the Stadium-Adjacent Parcels, other than areas occupied by buildings and any permissible building area, as are reasonably necessary, without materially interfering with the use of the Stadium-Adjacent Parcels, to provide rights-of-way for public or private utility services for the benefit of the Stadium Site and StadCo. The CC&Rs will address coordination of construction schedules and logistics, as reasonably necessary and required.

(d) Footing, Foundation and Attachment Easements. If required for the construction and maintenance of the Stadium foundation and footings, Metro will agree to establish such easements in, on, over and to the Stadium-Adjacent Parcels that abuts the Second Street Plaza for the construction and maintenance of foundations and footings to the extent reasonably necessary in connection with the construction of the Stadium for the benefit of the Stadium Site and StadCo, which easements will provide for, among other things, cooperation with respect to coordination of construction schedules so as to facilitate the construction of improvements on the Stadium Site and the Stadium-Adjacent Parcels.

(e) Additional Easements. The CC&Rs will address other easements reasonably required in connection with an integrated development, including without limitation,

easements for any physical integration and connections at, above or below ground level between various components of the Campus and the Stadium (e.g., pedestrian bridges and loading and service areas), permissible encroachments (if any), installation and existence of lights and signs, construction and lay-down areas (including schedules for the same), airspace rights and use of common areas.

(f) Easements Generally. If, to the extent that this Section 7.2 refers to an easement it may either be an easement or the closest utilitarian equivalent as required by Applicable Law.

Section 7.3 Operation and Maintenance. The Parties agree that the CC&Rs shall include operation and maintenance provisions (with typical provisions in favor of institutional Leasehold Mortgagees and other institutional mortgagees lending to any owner, lessee, or sublessee, which mortgagee's interest is secured by a Leasehold Mortgage or other institutional mortgage) as follows:Building and Utility Lateral Maintenance. The CC&Rs will obligate each owner to keep and maintain, or cause to be kept and maintained, at no expense to the other owners, all buildings and other improvements located on its site and will allocate costs associated therewith and include customary remedies for enforcement in the event such obligations are not satisfied.

(c) Maintenance and Operation of the Campus Park. The CC&Rs will obligate Metro or its designee, at its sole expense, subject to StadCo's obligations set forth below, to maintain the Campus Park. The CC&Rs will provide that StadCo (i) has the right, subject to any then- existing license (unless such license materially impairs StadCo from using a majority of the Campus Park) or Metro rules and regulations with respect to public parks, to use the Campus Park and to collect all revenues deriving from StadCo's use with respect to Stadium Events during Stadium Event Operational Periods, and (ii) is responsible for operating costs with respect to the use and operation of the Campus Park during Stadium Event Operational Periods and for any costs of repair for damage caused by StadCo or its invitees.

Section 7.4 Use Restrictions. The Parties agree that the CC&Rs shall include reasonable use restriction provisions as follows:Off-Premises Signage; Advertising. The CC&Rs will include reasonable provisions granting StadCo the right, subject to customary notice and cure periods, to enter the Stadium-Adjacent Parcels and the Campus Park to cover any signage or advertising installed in violation of Article 7 of this Agreement, as well as to recover reasonable costs and expenses incurred in connection with the same.

(c) Use of Campus Park. Metro and StadCo will cooperate to allocate, within the CC&Rs, rights with respect to rules regarding use of the Campus Park during Stadium Event Operational Periods.

(e) Alcohol Carry Provisions. The parties will work in good faith to address any rights or restrictions relating to alcohol consumption in the Campus Park and the Second Street Plaza.

(g) Interference with Access and Operations of StadCo. The CC&Rs will prohibit interference with access through portions of the Stadium-Adjacent Parcels into the Stadium Site, Campus Park and Second Street Plaza, subject to event protocols to be established

in accordance with the CC&Rs. Metro and StadCo shall work together to establish CC&Rs that protect the respective business interests of StadCo and the Campus Developer, including without limitation, establishing limitations upon actions that may result in the cannibalization of operations at the Stadium Site and Stadium-Adjacent Parcels.

Section 7.5 Additional Reserved Rights. The CC&Rs will address additional reserved rights as follows:Commercial and Campus Events Rights. To the extent appropriately addressed in recorded covenants and restrictions, the CC&Rs will address the commercial rights and the Campus event rights described in Section 8.5 of this Agreement.

(c) Additional Rights of StadCo. Metro and StadCo will work together in good faith to establish a method to establish rights in the CC&Rs in favor of StadCo and the Campus Developer as to signage, including without limitation, fixed and digital, sponsorship activation, programmatic advertising, data, food and beverage sales, merchandise sales, e-commerce, ticket and premium seating packages promotions, the provision of fintech services and application of venue tech throughout the Campus.

## **ARTICLE 8 CAMPUS USE AND OPERATION**

Section 8.1 Campus Park. Metro or its designee shall be responsible for the operation and cost of Campus Park maintenance, and the same shall be managed and maintained in clean and safe condition, and in accordance with all Applicable Laws. StadCo has the right to use the Campus Park and to collect all revenues deriving from StadCo's use with respect to Stadium Events during Stadium Event Operational Periods. StadCo is responsible for operational costs with respect to the use and operation of the Campus Park during Stadium Event Operational Periods, including any and all costs to repair damage to the Campus Park as a result of its use during Stadium Event Operational Periods. Notwithstanding anything herein to the contrary, no portion of the East Bank Greenway (i.e., the existing approximately 14-foot wide paved path located along the Cumberland River) shall be operated by StadCo in any manner that prohibits or limits public access thereto.

Section 8.2 Special Stadium Events. The Parties agree that Metro and the Campus Developer will work together in good faith to determine rights, obligations and other parameters relative to the Campus with respect to Special Stadium Events.

Section 8.3 License. Metro and the Campus Developer hereby grant StadCo and its Related Parties a license and right of access to the Campus for the purpose of performing StadCo's obligations and exercising its rights under this Agreement without charges or fees or the payment of rent other than reimbursement of operating expenses for the use and operation of the Campus Park during Stadium Event Operational Periods, and for any costs of repair for any damage caused by StadCo or its invitees, and subject to the terms of this Agreement and subject to compliance with applicable processes and procedures of Metro. Notwithstanding the foregoing, the rights of StadCo with respect to the Second Street Plaza are set forth in the IDA Coordination Agreements, and this Section 8.3 shall not apply thereto.

Section 8.4 Commercial Matters.

(a) Commercial Rights. Subject to the terms of the Stadium Lease and this Agreement, during the entire SCA Term, Metro, the Campus Developer and their respective Affiliates agree that StadCo shall have the sole and exclusive right to exercise all Advertising Rights, Concession Rights and Hospitality Rights at, on or within any portion of the Stadium, Second Street Plaza and the Campus Park with respect to Stadium Events during Stadium Event Operational Periods and those portions of temporary advertising solely exploited during such Stadium Events, including, the sole and exclusive right to operate, control and sell, and to retain all revenue from the foregoing, and subject to all Applicable Laws, exercise all Data Rights with respect to, at, on or within all or any portion of the Campus with respect to Stadium Events during Stadium Event Operational Periods. However, the Parties agree that the foregoing shall not preclude the Campus Developer or its licensee from operating existing permanent Concessions on the Campus during Stadium Event Operational Periods that are operating under a duly issued license by Governmental Authorities or operating under a license duly issued by a Governmental Authority. StadCo and the Campus Developer will meet and discuss in good faith the potential sharing of certain data derived from StadCo's Data Rights; provided, however, neither StadCo nor the Campus Developer will be under any obligation to share such data with the other Party.

(b) Campus Sponsors. Metro, the Campus Developer and their respective Affiliates agree that they will coordinate with StadCo and TeamCo with respect to the former Parties' solicitation and formal engagement of any Person (such Person, a "Campus Sponsor") to collectively maximize revenue for StadCo and the Campus Developer with respect to Advertising Rights at, on or within any portion of the Campus (excluding the Stadium, Second Street Plaza and Campus Park, which is governed by Section 7.5(b)). The Campus Developer also understands the importance of StadCo and TeamCo's Advertising Rights, and particularly those in a commercial category in which StadCo and TeamCo have granted category exclusivity, and the Developer agrees to work with StadCo in good faith in connection with Campus Sponsor solicitation and engagement acknowledging those concerns, subject to the terms of Ambush Marketing in 8.5(d).

(c) Additional Commercial Rights. Without limiting the foregoing, Metro and the Campus Developer acknowledge and agree as follows:

(i) Subject to the terms of the Stadium Lease and this Agreement, during the entire SCA Term, StadCo and TeamCo will have the sole and exclusive right at the Stadium (and throughout the Campus Park during Stadium Operational Periods) to schedule and control the exhibition, presentation and broadcasting (or other transmission) of all professional sporting events, amateur sporting events or activities, eSports, exhibitions and tournaments, musical performances, theater performances and other forms of live entertainment, fairs, markets, festivals, shows or other public or private exhibitions and activities related thereto (collectively, the "StadCo and TeamCo Events").

(ii) Without StadCo's prior written approval (such approval to be granted at StadCo's sole discretion), no Person shall have the right to control, conduct, sell, lease, license, publish, authorize and grant any opportunities with respect to sports betting and Casinos throughout the Campus, including, without limitation, (x) the right to conduct

and offer games of skill and chance through land-based facilities located on the Campus, or (y) the right to provide wagering on real world sports competitions on the Campus, in each case, to the extent permitted by, and in accordance with, Applicable Law, provided, however the foregoing shall not prohibit gambling or games of chance operated by the Tennessee Lottery or other Governmental Authorities throughout the Campus (other than within the Stadium). No Casino shall be allowed within the Campus without the approval of the Metropolitan Council by ordinance;

(iii) The Campus Developer shall use reasonable efforts to integrate StadCo's technology partners in the course of the design, development and operation of the Stadium-Adjacent Parcels, to achieve coordinated mobile technology, which efforts will include, without limitation, the Campus Developer participating in meetings with StadCo's technology partners and including such partners in requests for proposals and other similar opportunities to provide products and services for use throughout the Campus to enhance the experience of attending Stadium Events or being on the Campus and endeavoring to achieve revenue and cost synergies. Nonetheless, each of StadCo and the Campus Developer may pursue an independent technology solution after meeting in good faith if it determines that a joint approach is not practical or in its best interest. In addition, StadCo shall have the sole and exclusive right to control, conduct, sell, lease, license, publish, authorize and grant any Person metaverse opportunities and other similar digital experiences now existing or hereafter developed at the Stadium, and to receive, retain and control all data related thereto, including, digital real estate mapping, scavenger hunts (e.g., Pokemon Go), AR, VR, music, geotargeted advertising and promotions, games (e.g., Roblox), and future dApps (decentralized applications via Web3) and the right to mint or otherwise develop non-fungible tokens ("NFT") and other digital assets that, in each case, relate to the Team or any Stadium element (e.g., hotel stays, retail benefits, admission tickets, etc.), including, without limitation, any Stadium Event ("Digital Experiences and Assets"). Similarly, the Campus Developer shall retain similar rights with respect to the Campus property. With respect to the Second Street Plaza, StadCo and the Campus Developer agree to work in good faith to develop a plan regarding the foregoing rights and uses of Digital Experiences and Assets; and

(iv) StadCo and the Campus Developer shall have the right to sell and to retain all revenue from the sale of naming rights to the Second Street Plaza, provided that such naming rights shall be subject to a process that is subject mutual written approval of both StadCo and the Campus Developer.

(d) Ambush Marketing. Metro and the Campus Developer will use best efforts without the necessity to resort to exhaustive litigation and without diminishing StadCo's rights in law or equity to protect the Advertising Rights and other rights granted to StadCo under this Section 8.5 from Ambush Marketing. The Parties agree from time to time to discuss in good faith additional actions to be taken to protect StadCo from Ambush Marketing. Metro agrees to take all steps necessary at its own cost and expense to prevent non-sponsor advertisers from engaging in Ambush Marketing, which steps shall include, but not be limited to, Metro and the Campus Developer developing and implementing an Ambush Marketing protection strategy to combat Ambush Marketing and other instances of infringement of intellectual property rights. Metro and the Campus Developer will notify StadCo promptly in writing of any suspected instances of



Ambush Marketing or infringement of, or upon becoming aware of any unauthorized use of, TeamCo or StadCo's intellectual property that affects StadCo's rights hereunder and will assist TeamCo and StadCo in protecting TeamCo and StadCo Intellectual Property. Nothing in this Section 8.5 imposes any obligation on StadCo (or TeamCo, the NFL or any NFL Entity, where applicable) to commence proceedings or to take enforcement action against a third party. Without limiting Metro's and the Campus Developer's other obligations under this Section 8.5, Metro and the Campus Developer will work together in good faith to prevent Negative Advertising against StadCo and TeamCo and their Affiliates and their respective sponsors and other business parties.

(e) IDA Developer. The Parties acknowledge and agree that Metro, StadCo and the IDA Developer have entered into that certain Campus Operations and Use Agreement (the "COUA") pursuant to which each of Metro, StadCo and IDA Developer have agreed to certain terms and conditions regarding commercial matters related to or involving the Initial Development Area and the Second Street Plaza as further described therein (the "COUA Commercial Terms"), and notwithstanding anything to the contrary in this Section 8.4, the COUA shall govern with respect to the COUA Commercial Terms.

## **ARTICLE 9 INSURANCE AND INDEMNITY**

Section 9.1 Policies Required for Stadium Project Improvements Work. The Parties agree to develop insurance requirements that will be maintained by the Campus Developer and Campus Contractors and also StadCo, including coverages, limits, deductibles, endorsements, required additional insureds other industry standard requirements applicable to developments of this size and complexity. The additional insureds on applicable policies shall include, at a minimum, StadCo, TeamCo and its Affiliates or the Campus Developer and its Campus Contractors, as applicable.

Section 9.2 Indemnity. To the fullest extent permitted by Applicable Law, the Campus Developer agrees to defend, indemnify and hold harmless StadCo and its Affiliates from and against all claims, damages, loss, liabilities, fees and expense, including without limitation reasonable attorneys' fees and expenses and expert witness fees ("Loss") to the extent: (i) arising from a breach by Campus Developer of its obligations under this Agreement, (ii) arising out of or in any way incidental to any demolition, construction, use, occupancy or operation on or off the Campus or the Project Improvements incurred by or on behalf of StadCo or any StadCo Related Party, or any invitee or guest of StadCo; or (iii) caused by the negligent acts or omissions of the Campus Developer or a Campus Contractor in performing any work or services on the Campus, provided that such Loss results from bodily injury, sickness, disease or death or damage to property, including loss of use resulting therefrom. The Campus Developer's defense, indemnity and hold harmless obligation shall not extend to the sole negligence of an indemnified party.

Section 9.3 Waiver of Right of Recovery. TO THE EXTENT PERMITTED BY APPLICABLE LAW, AND WITHOUT AFFECTING THE INSURANCE COVERAGES REQUIRED TO BE MAINTAINED HEREUNDER OR AS MAY BE SUBSEQUENTLY DEVELOPED BY THE PARTIES, THE AUTHORITY, METRO, THE CAMPUS DEVELOPER (AND EACH CAMPUS CONTRACTOR), STADCO, TEAMCO AND THEIR AFFILIATES EACH WAIVE ALL RIGHTS OF RECOVERY, CLAIM, ACTION OR CAUSE OF ACTION

AGAINST THE OTHER FOR ANY DAMAGE TO PROPERTY, AND RELEASE EACH OTHER FOR SAME, TO THE EXTENT THAT SUCH DAMAGE (A) IS COVERED (AND ONLY TO THE EXTENT OF SUCH COVERAGE WITHOUT REGARD TO DEDUCTIBLES) BY PROPERTY INSURANCE ACTUALLY CARRIED BY THE PARTY HOLDING OR ASSERTING SUCH CLAIM OR (B) WOULD BE INSURED AGAINST UNDER THE TERMS OF ANY INSURANCE REQUIRED TO BE CARRIED UNDER THIS AGREEMENT BY THE PARTY HOLDING OR ASSERTING SUCH CLAIM. THIS PROVISION IS INTENDED TO RESTRICT EACH PARTY (IF AND TO THE EXTENT PERMITTED BY APPLICABLE LAW) TO RECOVERY AGAINST INSURANCE CARRIERS TO THE EXTENT OF SUCH COVERAGE AND TO WAIVE (TO THE EXTENT OF SUCH COVERAGE), FOR THE BENEFIT OF EACH PARTY, RIGHTS OR CLAIMS WHICH MIGHT GIVE RISE TO A RIGHT OF SUBROGATION IN ANY INSURANCE CARRIER. NEITHER THE ISSUANCE OF ANY INSURANCE POLICY REQUIRED UNDER, OR THE MINIMUM LIMITS SPECIFIED HEREIN SHALL BE DEEMED TO LIMIT OR RESTRICT IN ANY WAY A PARTY'S LIABILITY ARISING UNDER OR OUT OF THIS AGREEMENT PURSUANT TO THE TERMS HEREOF. AS BETWEEN (I) STADCO AND (II) THE CAMPUS DEVELOPER AND EACH CAMPUS CONTRACTOR, THE LATTER SHALL BE LIABLE FOR ANY LOSSES, DAMAGES OR LIABILITIES SUFFERED OR INCURRED BY STADCO, TEAMCO OR ITS AFFILIATES AS A RESULT OF ANY FAILURE TO OBTAIN, KEEP, AND MAINTAIN OR CAUSE TO BE OBTAINED, KEPT, AND MAINTAINED, THE TYPES OR AMOUNTS OF INSURANCE REQUIRED TO BE KEPT OR MAINTAINED OR CAUSED TO BE KEPT OR MAINTAINED BY UNDER THE TERMS OF THIS AGREEMENT.

Section 9.4 Indirect, Special, Exemplary or Consequential Damages. NO PARTY WILL BE LIABLE TO ANY OTHER PARTY FOR ANY INDIRECT, SPECIAL, EXEMPLARY, PUNITIVE, OR CONSEQUENTIAL DAMAGES OR LOSSES OF ANY KIND OR NATURE, INCLUDING DAMAGES FOR LOSS OF PROFITS, BUSINESS INTERRUPTION OR LOSS OF GOODWILL ARISING FROM OR RELATING TO THIS AGREEMENT, EVEN IF SUCH PARTY IS EXPRESSLY ADVISED OF THE POSSIBILITY OF SUCH DAMAGES. A Party's elected officials, appointed officials, board members, members, shareholders and other owners, directors, officers, employees, agents, and attorneys or other representatives shall not be personally liable for any obligations or other matters arising under this Agreement.

## **ARTICLE 10 DEFAULTS AND REMEDIES**

Section 10.1 Events of Default and Remedies. The Parties will work in good faith to develop a mutually agreeable default and remedy clause with respect to matters arising out of this Agreement. The Parties specifically agree that any such default and remedy clause shall include a provision that says this Agreement shall terminate upon termination of the Lease Agreement pursuant to its terms; and that, otherwise, the Parties to this Agreement may not terminate this

Agreement on any other grounds. For avoidance of doubt, the Parties agree that any amendments to this Section implementing the foregoing clause are subject to Section 13.2.

## **ARTICLE 11 STANDARDS FOR APPROVALS**

Section 11.1 Review and Approval Rights. The provisions of this Article 11 shall be applicable with respect to all instances in which it is provided under this Agreement that StadCo or the StadCo Representative, Metro or the Metro Representative, or any Developer exercises Review and Approval Rights; *provided, however*, that if the provisions of this Article 11 specifying time periods for exercise of Review and Approval Rights shall conflict with other express provisions of this Agreement providing for time periods for exercise of designated Review and Approval Rights, then the provisions of such other provisions of this Agreement shall control. As used herein, the term “Review and Approval Rights” shall include, without limiting the generality of that term, all instances in which one Party (the “Submitting Party”) is permitted or required to submit to the other Party or to the representative of that other Party any document, notice or determination of the Submitting Party and with respect to which the other Party or its representative (the “Reviewing Party”) has a right or duty hereunder to review, comment, confirm, consent, Approve, disapprove, dispute or challenge the submission or determination of the Submitting Party.

### Section 11.2 Standard for Review.

(a) General. Unless this Agreement specifically provides that a Party’s Review and Approval Rights may be exercised in the sole discretion of the Reviewing Party, then in connection with exercising its Review and Approval Rights under any provision of this Agreement, and whether or not specifically provided in any such provision, the Reviewing Party covenants and agrees to act in good faith, with due diligence, and in a fair and commercially reasonable manner in its capacity as Reviewing Party with regard to each and all of its Review and Approval Rights and to not unreasonably withhold, condition or delay its Approval of, consent to or confirmation of any submission or determination. The Reviewing Party shall review the matter submitted in writing and shall promptly (but in any event within fifteen (15) days after such receipt) give Notice to the Submitting Party of the Reviewing Party’s comments resulting from such review and, if the matter is one that requires Approval or confirmation pursuant to the terms of this Agreement, such Approval, confirmation, disapproval or failure to confirm, setting forth in detail the Reviewing Party’s reasons for any disapproval or failure to confirm. Any failure to respond within the foregoing fifteen (15) day period shall not be deemed to be an approval or confirmation of the matter submitted unless within five (5) Business Days thereafter the submitting party resubmits the matter in writing with a prominent, all capital letters disclaimer that states – THIS IS A RESUBMISSION OF A PREVIOUSLY SUBMITTED MATTER TO WHICH TIMELY RESPONSE WAS NOT MADE AND FAILURE TO RESPOND TO THIS RESUBMISSION WITHIN A FURTHER TEN (10) DAYS SHALL BE DEEMED TO BE AN APPROVAL ASSUMING THAT PERFORMANCE OF THE SUBMITTED MATTER IS LAWFUL.

(b) Specific Matters. Unless otherwise provided herein, the Reviewing Party’s right to disapprove or not confirm any matter submitted to it for Approval or confirmation

and to which this Section 11.2 applies shall be limited to the elements thereof: (a) that do not conform in all material respects to Approvals or confirmations previously given with respect to the same matter; (b) that propose or depict matters that are or the result of which would be a violation of or inconsistent with the provisions of this Agreement or Applicable Law, and (c) ensure functional coordination with the Stadium Plans.

Section 11.3 Resubmissions. If the Reviewing Party disapproves of or fails to confirm a matter to which this Section 11.3 applies within the applicable time period, the Submitting Party shall have the right, within twenty (20) days after the Submitting Party receives Notice of such disapproval or failure to confirm, to re-submit the disapproved or not confirmed matter to the Reviewing Party, altered to satisfy the Reviewing Party's basis for disapproval or failure to confirm (all subsequent re-submissions with respect to such matter must be made within ten (10) days of the date the Submitting Party receives Notice of disapproval or failure to confirm of the prior re-submission). The applicable Submitting Party shall use reasonable efforts to cause any such re-submission to expressly state that it is a re-submission, to identify the disapproved or not confirmed portion of the original submission and any prior resubmissions, and to not be included with an original submission unless the matter previously disapproved is expressly identified thereon. Any resubmission made pursuant to this Section 11.3 shall be subject to Review and Approval Rights of the Reviewing Party in accordance with the procedures described in this Article 10 for an original submission (except that the Review and Approval Rights shall be limited to the portion previously disapproved or not confirmed), until such matter shall be Approved by the Reviewing Party.

Section 11.4 Duties, Obligations, and Responsibilities Not Affected. Approval or confirmation by the Reviewing Party of or to a matter submitted to it by the Submitting Party shall neither, unless specifically otherwise provided (a) relieve the Submitting Party of its duties, obligations or responsibilities under this Agreement with respect to the matter so submitted nor (b) shift the duties, obligations or responsibilities of the Submitting Party with respect to the submitted matter to the Reviewing Party.

## **ARTICLE 12 DISPUTE RESOLUTION**

Section 12.1 Settlement By Mutual Agreement. In the event any dispute, controversy or claim between or among the Parties arises under this Agreement or any right, duty or obligation arising therefrom or the relationship of the Parties thereunder (a "Dispute or Controversy"), including a Dispute or Controversy relating to the (a) effectiveness, validity, interpretation, implementation, termination, cancellation or enforcement of this Agreement or (b) the granting or denial of any Approval under this Agreement, the Parties shall first attempt in good faith to settle and resolve such Dispute or Controversy by mutual agreement in accordance with the terms of this Section 12.1. In the event a Dispute or Controversy arises, either Party shall have the right to notify the other that it has elected to implement the procedures set forth in this Section 12.1. Within fifteen (15) days after delivery of any such notice by one Party to the other regarding a Dispute or Controversy, each Party's representative shall meet at a mutually agreed time and place to attempt, with diligence and good faith, to resolve and settle such Dispute or Controversy. If a mutual resolution and settlement are not obtained at the meeting of the Party's representatives, they shall cooperate in a commercially reasonable manner to determine if mediation or other forms of

alternative dispute resolution might be useful. If a technique is agreed upon, a specific timetable and completion date for implementation shall also be agreed upon. If such technique, timetable or completion date is not agreed upon within thirty (30) days after the notice of the Dispute or Controversy was delivered, or if no resolution is obtained through such alternative technique, or if no such meeting takes place within the fifteen (15)-day period, then either Party may file suit in a court of competent jurisdiction in Davidson County, Tennessee.

### **ARTICLE 13 EFFECT OF IDA COORDINATION AGREEMENTS**

Section 13.1 Exclusion of the Initial Development Area. Notwithstanding anything herein to the contrary, the provisions of this Agreement shall not be applicable to the (i) Campus Improvements Work contemplated by the IDA Development Agreement and/or any IDA Ground Lease or (ii) rights and responsibilities of the IDA Developer and any IDA Ground Tenant with respect to parcels of Campus property, so long as such parcels remain part of the Initial Development Area, as contemplated by the IDA Development Agreement, the IDA Ground Leases and the IDA Coordination Agreements; instead, the rights and responsibilities of Metro, the IDA Developer, each IDA Ground Tenant and StadCo with respect thereto shall be governed by the IDA Coordination Agreements. For the avoidance of doubt, (i) this Agreement does not apply to the IDA Developer, any IDA Ground Tenant, the parcels of Campus property within the Initial Development Area or any Campus Improvements Work contemplated by the IDA Development Agreement or IDA Ground Leases; and (ii) the Metropolitan Government shall have no responsibilities as a Campus Developer under this Agreement with respect to any parcel of Campus property within the Initial Development Area or any Campus Improvements Work contemplated by the IDA Development Agreement or IDA Ground Leases, except to the extent such parcel subsequently is treated under Section 13.3 of this Agreement as a Future Development Area.

Section 13.2 Application to Future Development Area. The Parties agree that, in connection with the execution of a Campus Development Agreement contemplating the development of any parcel of the Future Development Area, the execution and delivery of agreements (or other documents or instruments, as applicable) substantially similar to the IDA Coordination Agreements shall likewise be sufficient to exclude (i) the Campus Improvements Work contemplated by such Campus Development Agreement, and (ii) the rights and responsibilities of the Campus Developer and any ground tenant of such parcel of the Future Development Area from the provisions of this Agreement; and in such case, the rights and responsibilities of the parties to such agreements, documents or instruments shall be as set forth therein. The Parties agree that, in determining whether such agreements, documents or instruments are substantially similar to the IDA Coordination Agreements, provisions related to Future Development Area parcels that are not Stadium-Adjacent Parcels will be evaluated solely against provisions of the IDA Coordination Agreements that relate to parcels within the Initial Development Area that are not Stadium-Adjacent Parcels. The Parties shall in good faith discuss any objections StadCo, Metro and/or any actual or prospective Campus Developer may have to the execution and delivery of such substantially similar agreements, documents or instruments in connection with the development, design, construction, operation and maintenance improvement of one or more parcels within the Future Development Area. Notwithstanding the foregoing, all provisions of this Agreement applicable to the Campus Park shall remain in effect as set forth herein.

Section 13.3 Removal of Campus Property from the Initial Development Area. Any parcel of Campus property that ceases to be subject to either the IDA Development Agreement or an IDA Ground Lease shall cease to be treated hereunder as part of the Initial Development Area, and shall thereafter be treated as being within the Future Development Area. The Metropolitan Government shall provide written notice to StadCo within 30 days following the date on which any parcel of Campus property ceases to be included within the Initial Development Area as described in the preceding sentence.

**ARTICLE 14**  
**MISCELLANEOUS PROVISIONS**

Section 14.1 Notices. All notices, requests, Approvals or other communications required under this Agreement shall be in writing and shall be deemed to have been properly given if served personally, or if sent by United States registered or certified mail, or overnight delivery service to the Parties as follows (or at such other address as a Party may from time to time designate by Notice given pursuant to this Section 13.1(a)):

To Metro: Nashville City Hall, Suite 100  
1 Public Square  
Nashville, Tennessee 37201  
Attn.: Mayor

with a copy to: Metropolitan Department of Law  
1 Public Square, Suite 108  
Nashville, Tennessee 37201  
Attn.: Director of Law

Greenberg Traurig, LLP  
1000 Louisiana Street, Suite 6700  
Houston, Texas 77002  
Attn: Denis C. Braham

To StadCo: Tennessee Stadium, LLC  
St. Thomas Sports Park  
460 Great Circle Road  
Nashville Tennessee 37228  
Attn: President/CEO

with a copy to: Tennessee Stadium, LLC  
St. Thomas Sports Park  
460 Great Circle Road  
Nashville Tennessee 37228  
Attn: Chief Operating Officer

with a copy to: DLA Piper LLP  
One Fountain Square  
11911 Freedom Drive Suite 300  
Reston, VA 20190-5602  
Attn: Mark Whitaker

Each notice shall be deemed given and received on the date delivered if served personally or by overnight delivery service or, if sent by United States registered or certified mail, then one (1) Business Day after its delivery to the address of the respective Party, as provided in this Section 14.1, except that with respect to the notices pertaining to matters that are to be accomplished within less than three (3) Business Days (e.g., requests for Approvals when the Person whose Approval is sought has one (1) Business Day to respond in the granting or denying of such Approval), Notice shall be deemed given simultaneously with its delivery. Notices sent by a Party's counsel shall be deemed notices sent by such Party.

Section 14.2 Amendment. This Agreement may be amended, modified or supplemented but only in a writing signed by each of the Parties. A signed writing by the Metropolitan Government to implement any such amendment, modification or supplementation shall be pursuant to a resolution of the Metropolitan Council.

Section 14.3 Waivers. The failure of a party hereto at any time or times to require performance of any provision hereof shall in no manner affect its right at a later time to enforce the same. No waiver by a Party of any condition or of any breach of any term, covenant, representation or warranty contained in this Agreement shall be effective unless in writing, and no waiver in any one or more instances shall be deemed to be a further or continuing waiver of any such condition or breach in other instances or a waiver of any other condition or breach of any other term, covenant, representation or warranty.

Section 14.4 Counterparts. This Agreement may be executed and delivered in counterparts, each of which shall be deemed an original, but all of which together shall constitute one and the same instrument. A facsimile or other electronic signature (including a .pdf) of any party shall be considered to have the same binding effect as an original signature.

Section 14.5 Knowledge. The term "knowledge" or words of similar import shall mean the knowledge after reasonable inquiry of the officers or key employees of any Party with respect to the matter in question as to the date with respect to which such representation or warranty is made.

Section 14.6 Drafting. The Parties acknowledge and confirm that each of their respective attorneys have participated jointly in the review and revision of this Agreement and that it has not been written solely by counsel for one Party. The Parties further agree that the language used in this Agreement is the language chosen by the Parties to express their mutual intent and that no rule of strict construction is to be applied against any Party.

Section 14.7 No Third-Party Beneficiaries. This Agreement is solely for the benefit of the Parties hereto and the Team and, to the extent provided herein, their respective Affiliates, board members, agents, successors, and permitted assigns, and no provision of this Agreement shall be

deemed to confer upon other Persons any remedy, claim, liability, reimbursement, cause of action or other right.

Section 14.8 Entire Understanding. This Agreement, the Stadium Lease and the other Project Documents set forth the entire agreement and understanding of the Parties hereto with respect to the transactions contemplated hereby and supersede any and all prior agreements, arrangements, and understandings among the Parties relating to the subject matter hereof, and any and all such prior agreements, arrangements, and understandings shall not be used or relied upon in any manner as parol evidence or otherwise as an aid to interpreting this Agreement. This Agreement amends and restates the Original SCA in its entirety.

Section 14.9 Termination Upon Termination of Stadium Development Agreement. Notwithstanding the provisions of Article 3 hereof, upon an Unwinding (as defined in the Stadium Development Agreement) pursuant to Section 3.6 of the Stadium Development Agreement, this Agreement shall be of no further force or effect; provided however that the Metropolitan Government shall take all steps necessary to cause the Campus (or portions thereof) to be either conveyed to the Sports Authority or otherwise operated by the Metropolitan Government in a manner that fully preserves the rights of the lessee under Section 3.7 of the Existing Lease related to the operation of parking facilities.

Section 14.10 Governing Law, Venue; Waiver of Jury.

(a) Governing Law. This Agreement and the transactions contemplated hereby, and all disputes between the Parties under or related to the Agreement or the facts and circumstances leading to its execution, whether in contract, tort or otherwise, shall be governed by and construed in accordance with the laws of the State of Tennessee, applicable to contracts executed in and to be performed entirely within the State of Tennessee, without regard to the conflicts of laws principles thereof.

(b) Venue. Subject to the terms of Article 11, each of the Parties hereby irrevocably and unconditionally submits, for itself and its Property, to the exclusive jurisdiction of the Chancery Court of Davidson County, Tennessee or federal court of the United States of America and any appellate court from any thereof, in any proceeding arising out of or relating to this Agreement or the agreements delivered in connection herewith or the transactions contemplated hereby or thereby or for recognition or enforcement of any judgment relating thereto, and each of the Parties hereby irrevocably and unconditionally (i) agrees not to commence any such proceeding except in such courts, (ii) agrees that any claim in respect of any such proceeding may be heard and determined in the Chancery Court of Davidson County, Tennessee or in such federal court, (iii) waives, to the fullest extent it may legally and effectively do so, any objection which it may now or hereafter have to the laying of venue of any such proceeding in any such court, and (iv) waives, to the fullest extent permitted by law, the defense of an inconvenient forum to the maintenance of such action or proceeding in any such court. Each of the Parties agrees that a final judgment in any such proceeding shall be conclusive and may be enforced in other jurisdictions by suit on the judgment or in any other manner provided by law.

(c) Waiver of Jury Trial. EACH PARTY ACKNOWLEDGES AND AGREES THAT ANY CONTROVERSY WHICH MAY ARISE UNDER THIS AGREEMENT IS



LIKELY TO INVOLVE COMPLICATED AND DIFFICULT ISSUES, AND THEREFORE IT HEREBY IRREVOCABLY AND UNCONDITIONALLY WAIVES ANY RIGHT IT MAY HAVE TO A TRIAL BY JURY IN RESPECT OF ANY LITIGATION DIRECTLY OR INDIRECTLY ARISING OUT OF OR RELATING TO THIS AGREEMENT AND ANY OF THE AGREEMENTS DELIVERED IN CONNECTION HEREWITH OR THE TRANSACTIONS CONTEMPLATED HEREBY OR THEREBY. EACH PARTY HERETO CERTIFIES AND ACKNOWLEDGES THAT (I) NO REPRESENTATIVE, AGENT OR ATTORNEY OF ANY OTHER PARTIES HAS REPRESENTED, EXPRESSLY OR OTHERWISE, THAT SUCH OTHER PARTIES WOULD NOT, IN THE EVENT OF LITIGATION, SEEK TO ENFORCE EITHER OF SUCH WAIVERS, (II) IT UNDERSTANDS AND HAS CONSIDERED THE IMPLICATIONS OF SUCH WAIVERS, (III) IT MAKES SUCH WAIVERS VOLUNTARILY, AND (IV) IT HAS BEEN INDUCED TO ENTER INTO THIS AGREEMENT BY, AMONG OTHER THINGS, THE MUTUAL WAIVERS AND CERTIFICATIONS IN THIS SECTION 14.10. THIS SECTION SHALL SURVIVE ANY TERMINATION OF THIS AGREEMENT.

Section 14.11 Time is of the Essence. The times for performance provided in this Agreement are essential due to the obligations and expenditures of the Parties. If a time is not specified, performance shall be required promptly and with due regard to the conditions of performance of other Parties in reliance thereon. All provisions in this Agreement that specify or provide a method to compute a number of days for the performance, delivery, completion or observance by a Party of any action, covenant, agreement, obligation or notice hereunder shall mean and refer to calendar days, unless otherwise expressly provided. However, if the date specified or computed under this Agreement for the performance, delivery, completion or observance of a covenant, agreement, obligation or notice by either Party, or for the occurrence of any event provided for herein, is a Saturday, Sunday or Legal Holiday, then the date for such performance, delivery, completion, observance or occurrence shall automatically be extended to the next calendar day that is not a Saturday, Sunday or Legal Holiday.

Section 14.12 Severability. If any provision of this Agreement shall be held invalid, illegal or unenforceable, the validity, legality or enforceability of the other provisions hereof shall not be affected thereby, and there shall be deemed substituted for the provision at issue a valid, legal and enforceable provision as similar as possible to the provision at issue. This Section 14.12 shall not be construed or implemented in a manner that substantially deprives any Party of the overall benefit of its bargain under this Agreement.

Section 14.13 Relationship of the Parties. Metro, the Campus Developer and StadCo are independent parties and nothing contained in this Agreement shall be deemed to create a partnership, joint venture, agency or employer-employee relationship among them or to grant to any of them any right to assume or create any obligation on behalf of or in the name of the others of them.

Section 14.14 Further Assurances/Additional Documents and Approval. A Party, upon reasonable request of the other Party, shall execute and deliver, or cause to be executed and delivered, any additional documents and shall take such further actions as may be reasonably necessary or expedient in order to consummate the transactions provided for in, and to carry out

the purpose and intent of, this Agreement and/or to comply with or satisfy the requirements of the Act.

Section 14.15 Recording. This Agreement shall not be recorded, but at the request of any Party, the Parties shall promptly execute, acknowledge, and deliver to each other a memorandum of agreement in a form reasonably agreed upon by the Parties (and a memorandum of modification of agreement in respect of any modification of this Agreement) sufficient for recording. Such memorandum shall not be deemed to change or otherwise affect any of the obligations or provisions of this Agreement and shall confirm that this Agreement runs with the Land under Section 14.18 hereof.

Section 14.16 Estoppel Certificate. Each of the Parties agrees that within ten (10) Business Days after receipt of a written request by any other Party, shall execute, acknowledge, and deliver to the requesting party a statement in writing certifying: (a) that this Agreement is unmodified and in full force and effect or, if there have been modifications, that the same are in full force and effect as modified and identifying the modifications; and (b) that such Party is not (to the best of that Party's knowledge) in default under any provisions of this Agreement or, if there has been a default, the nature of such default.

Section 14.17 No Personal Liability to Representatives and Owners. No owner, member, officer, director, manager, employee, agent, appointee, representative or other individual acting in any capacity on behalf of either of the Parties or their Affiliates shall have any personal liability or obligations under, pursuant to, or with respect to this Agreement for any reason whatsoever.

Section 14.18 Runs with the Land. During the SCA Term, this Agreement, and StadCo's rights hereunder, each constitute an interest in the Land, and the Parties intend that interest be non-revocable and assignable, in each case, in accordance with, but subject to the terms of this Agreement; and constitute an interest in real estate that runs with title to the Land, and inures to the benefit of and is binding upon the Parties and their respective permitted successors in title and permitted assigns, subject to the terms of this Agreement.

Section 14.19 Prohibition Against Boycotting Israel. To the extent this Agreement constitutes a contract with to acquire or dispose of services, supplies, information technology, or construction for the purposes of Tennessee Code Annotated Section 12-4-119, neither StadCo, nor any of its wholly owned subsidiaries, majority-owned subsidiaries, parent companies or affiliates, are currently engaged in nor will they engage in a boycott of Israel from the date hereof through the expiration or termination of this Agreement. For the purposes of Section 12-4-119, "boycott of Israel" shall mean engaging in refusals to deal, terminating business activities, or other commercial actions that are intended to limit commercial relations with Israel, or companies doing business in or with Israel or authorized by, licensed by, or organized under the laws of the State of Israel to do business, or persons or entities doing business in Israel, when such actions are taken (i) in compliance with, or adherence to, calls for a boycott of Israel, or (ii) in a manner that discriminates on the basis of nationality, national origin, religion, or other unreasonable basis, and is not based on a valid business reason.

Section 14.20 Public Records. The Parties agree that StadCo is not an office, department, or agency of Metro for purposes of Tennessee Code Annotated Sections 10-7-403 and 10-7-701.

StadCo is not a custodian of records for Metro, nor is StadCo responsible for maintaining the Metro's documents arising from or relating to this Agreement or the Campus Improvements.

Section 14.21 Permitted Assignment by Metro. Metro may assign its rights hereunder to one or more agencies or instrumentalities of the Metropolitan Government or designate one or more agencies or instrumentalities to act on its behalf.

[Remainder of Page Left Blank Intentionally]

IN WITNESS WHEREOF, this Agreement has been executed by the Parties as of the Effective Date.

THE METROPOLITAN GOVERNMENT OF  
NASHVILLE AND DAVIDSON COUNTY

By: \_\_\_\_\_  
Metropolitan Mayor

ATTEST:

By: \_\_\_\_\_  
Metropolitan Clerk

APPROVED AS TO FORM AND LEGALITY:

\_\_\_\_\_  
Director of Law

TENNESSEE STADIUM, LLC, a Delaware limited  
liability company

By: \_\_\_\_\_

**EXHIBIT A  
TO  
SITE COORDINATION AGREEMENT**

**GLOSSARY OF DEFINED TERMS AND RULES OF USAGE**

“Act” shall mean the Sports Authorities Act of 1993, codified as Chapter 67, of Title 7 of the Tennessee Code Annotated, as more fully described in the Recitals.

“Actions or Proceedings” shall mean any lawsuit, proceeding, arbitration or other alternative dispute resolution process, Governmental Authority investigation, hearing, audit, appeal, administrative proceeding, or judicial proceeding.

“Advertising Rights” means the right to display, control, conduct, lease, permit, sell, publish and enter into agreements regarding the display of all Advertising.

“Advertising” means, collectively, any of the following: advertising, sponsorship and promotional activity, signage, designations (including, but not limited to, “pouring rights” or similar designations and rights of exclusivity and priority), messages and displays of every kind and nature, whether now existing or developed in the future, including, without limitation, permanent, non-permanent and transitory signage or advertising displayed on non-permanent advertising panels or on structures, fixtures or equipment (such as scoreboard advertising and canopy advertising); audio or video public address advertising and message board advertising; programs; electronic insertion and other forms of virtual signage (such as digital bowl signage); sponsor-identified projected images; advertising on or in schedules, admission tickets and yearbooks; all other print and display advertising; promotional events sponsored by advertisers; advertising display items worn or carried by concessionaries or personnel engaged in the operation of any Stadium Events; and logo, slogan or other forms of advertising affixed to or included with cups, hats or T-shirts; advertising of Concessions; advertising through broadcast rights; and other concession, promotional or premium advertising items. The parties acknowledge that permanent rights, as used in this definition, does not apply in all instances to the Campus Park, Campus or the Second Street Plaza.

“Affiliate” shall mean, with respect to a specified Person, any other Person that, directly or indirectly, through one or more intermediaries, Controls, is Controlled by or is under common Control with the Person specified. For purposes of this definition, the terms “Controls,” “Controlled by” or “under common Control” shall mean the possession, direct or indirect, of the power to direct or cause the direction of the management and policies of a Person.

“Agreement” shall have the meaning set forth in the preamble of this Agreement.

“Ambush Marketing” means any attempt by another Person, without StadCo or TeamCo or one of their respective Affiliate’s consent or the NFL’s consent, to associate itself or its products or services with the Team, the NFL, or any of the NFL’s Entities, or to directly or indirectly suggest that such product or service is endorsed by or otherwise associated with the Team, StadCo, the NFL or any of the NFL Entities. Ambush Marketing shall include, but not be limited to, the unauthorized use of StadCo and TeamCo’s intellectual property; the unauthorized use of free tickets for Stadium Events in consumer prize giveaways, contests, sweepstakes or other

promotions; the creation of any advertising that incorporates a theme or image that would lead a reasonable person to believe the non-sponsor advertiser is in some way associated with or has been endorsed by the Team, StadCo, the NFL, or any of the NFL's Entities; and any other advertising, marketing, or promotion that is undertaken by an unauthorized third party and gives the public the impression that the unauthorized third party: (i) has an official association, approval or sponsorship with the with the Team, StadCo, the NFL of any of the NFL Entities, or (ii) otherwise to imply a direct or indirect association, approval, or sponsorship with the Team, StadCo, the NFL of any of the NFL Entities as a means of promoting the unauthorized third party's business, products, or services.

“Applicable Law(s)” or “applicable law(s)” or “Law(s)” shall mean any and all laws (including all statutory enactments and common law), ordinances, constitutions, regulations, treaties, rules, codes, standards, permits, requirements, and orders that (a) have been adopted, enacted, implemented, promulgated, ordered, issued, entered or deemed applicable by or under the authority of any Governmental Authority or arbitrator having jurisdiction over a specified Person (or the properties or assets of such Person), and (b) are applicable to this Agreement or the performance of the obligations of the parties under this Agreement.

“Approval” or “approve” shall mean (a) with respect to any item or matter for which the approval of Metro or its representatives, as the case may be, is required under the terms of this Agreement, the specific approval of such item or matter by them pursuant to a written instrument executed by Metro or its representatives, as applicable, delivered to StadCo, and shall not include any implied or imputed approval, but shall include any approval that is deemed approved pursuant to the terms of this Agreement, and no approval by Metro or its representatives pursuant to this Agreement shall be deemed to constitute or include any approval required in connection with any governmental functions of Metro; (b) with respect to any item or matter for which the approval of StadCo is required under the terms of this Agreement, the specific approval of such item or matter by StadCo or the StadCo Representative, as the case may be, pursuant to a written instrument executed by a duly authorized officer of StadCo or the StadCo Representative, as permitted pursuant to the terms of this Agreement, and delivered to the Sports Authority and shall not include any implied or imputed approval, but shall include any approval that is deemed approved pursuant to the terms of this Agreement; and (c) with respect to any item or matter for which the approval of any other Person is required under the terms of this Agreement, the specific approval of such item or matter by such Person pursuant to a written instrument executed by a duly authorized representative of such Person and delivered to the other Party, and shall not include any implied or imputed approval. In such use, all Approvals shall not be unreasonably withheld, conditioned or delayed, unless the terms of this Agreement specify otherwise.

“Business Day” shall mean a day of the year that is not a Saturday, Sunday, Legal Holiday or a day on which commercial banks are not required or authorized to close in Nashville, Tennessee.

“Business Hours” shall mean 9:00 a.m. through 5:00 p.m. on Business Days.

“Campus” shall have the meaning set forth in the Recitals of this Agreement.

“Campus Contract(s)” shall have the meaning set forth in Section 5.7(a) of this Agreement.

“Campus Contractor” shall mean the Person(s) who is(are) the counterparty(ies) to a Campus Contract with Metro or the Campus Developer (as the case may be).

“Campus Developer” shall have the meaning set forth in the Recitals of this Agreement.

“Campus Improvements” shall have the meaning ascribed by Section 5.1.

“Campus Improvements Construction Schedule” shall mean the construction schedule for the applicable component of the Campus Improvements in question showing the relative times for performance of all significant tasks included for that portion of the Campus Improvements Work.

“Campus Improvements Work” shall have the meaning set forth in Section 5.1 of this Agreement.

“Campus Infrastructure” shall mean all utilities, roads and other infrastructure required for the use and operation of the Campus.

“Campus Park” shall have the meaning set forth in Section 6.7.

“Campus Park Area” shall have the meaning set forth in Section 6.7.

“Casino” shall mean a building or any portion thereof that provides gambling-based games typically found in casinos that consist of dealing, operating, carrying on, conducting, maintaining, or exposing for play any game played with cards, dice, equipment, or any mechanical or electromechanical device, such as poker, roulette, craps, twenty-one, black jack, baccarat, slot machines, keno, or any other gambling-based game similar in form or content where money or credit is wagered. A building shall not be considered a Casino solely because such building (or any portion thereof) provides (i) legalized sports betting and/or (ii) raffles or lotteries which are sponsored or operated by the State or other Governmental Authorities.

“CC&Rs” shall have the meaning set forth in Section 7.1 of this Agreement.

“CMAR” shall have the meaning set forth in the Stadium Development Agreement.

“Commissioner” shall mean the Commissioner of the NFL.

“Concessions” means, collectively, all food and beverages, including all alcoholic beverages (subject to procurement of all necessary Government Approvals), and Merchandise.

“Concession Rights” means the right to market, sell, display, distribute and store Concessions and to conduct catering and banquet sales and service, including, but not limited to, catering sales and service with respect to private areas located in the Stadium (e.g., private suites and media and broadcast areas).

“Construction Manager at Risk or CMAR” shall have the meaning ascribed by the Stadium Development Agreement.

“Construction Manager at Risk Agreement” shall mean the Guaranteed Maximum Price agreement between the CMAR and StadCo dated for the construction of the Project Improvements, including all schedules and exhibits attached to the Construction Manager at Risk Agreement.

“COUA” shall have the meaning set forth in Section 8.4(e) of this Agreement.

“COUA Commercial Terms” shall have the meaning set forth in Section 8.4(e) of this Agreement.

“Cumberland” means Cumberland Stadium, Inc., a Delaware corporation.

“Data Rights” means the right to collect, use, sell, license, display, publish or otherwise use, names, contact information and other identifiable information with respect to those attending Stadium Events.

“Day(s)” or “day(s)” shall mean calendar days, including weekends and legal holidays, whether capitalized or not, unless otherwise specifically provided.

“Declaration” shall have the meaning set forth in the Recitals of this Agreement.

“Default Rate” shall mean an interest rate equal to the prime rate in effect on the date that the applicable underlying payment was required to be made (as reported in *The Wall Street Journal*) plus four percent (4%).

“Development Parcel B” shall have the meaning set forth in the Recitals of this Agreement.

“Development Parcel C” shall have the meaning set forth in the Recitals of this Agreement.

“Dispute or Controversy” shall have the meaning set forth in Section 12.1 of this Agreement.

“Effective Date” shall have the meaning set forth in the preamble of this Agreement.

“Environmental Law(s)” shall mean all Applicable Laws, including any consent decrees, settlement agreements, judgments or orders, issued by or entered into with a Governmental Authority pertaining or relating to: (a) pollution or pollution control; (b) protection of human health or the environment; (c) the presence, use, management, generation, processing, treatment, recycling, transport, storage, collection, disposal or release or threat of release of any Hazardous Materials; or (d) the protection of endangered or threatened species.

“Existing Stadium” shall mean the existing Nissan Stadium located on the east bank of the Cumberland River that is the current home stadium for the Tennessee Titans.

“Existing Stadium Events” means Team Events and any and all other events or activities of any kind at the Existing Stadium which are permitted under the Existing Stadium Lease, excluding events hosted by the Sports Authority.



“Existing Stadium Lease” means that certain Stadium Lease, dated as of May 14, 1996, as amended, between the Sports Authority, as lessor, and Cumberland Stadium, L.P., as lessee, related to the Existing Stadium.

“Future Development Area” shall have the meaning set forth in the Recitals of this Agreement.

“Governmental Authority” shall mean any federal, state, county, city, local or other government or political subdivision, court or any agency, authority, board, bureau, commission, department or instrumentality thereof.

“Hazardous Materials” shall mean (a) any substance, emission or material including asbestos, now or hereafter defined as, listed as or specified in an Applicable Law as a “regulated substance,” “hazardous substance,” “toxic substance,” “pesticide,” “hazardous waste,” “hazardous material” or any similar or like classification or categorization under any Environmental Law including by reason of ignitability, corrosivity, reactivity, carcinogenicity or reproductive or other toxicity of any kind, or (b) any products or substances containing petroleum, asbestos, or polychlorinated biphenyls.

“Hospitality Rights” means the right to market and sell hospitality assets related to the Stadium during the Stadium Event Operational Period, including, without limitation, suites, tickets, experiences, Concessions and Merchandise.

“IDA Coordination Agreements” shall have the meaning set forth in the Recitals.

“IDA Developer” shall have the meaning set forth in the Recitals.

“IDA Ground Tenant” shall have the meaning set forth in the Recitals.

“Infrastructure Improvements” shall mean all improvements off of the Land that are reasonably determined to be necessary for the Stadium by StadCo, the Nashville Department of Transportation, Metropolitan Water Services, Nashville Electric Service, and/or Piedmont Natural Gas after the date hereof as a result of the actions of StadCo and any demolition work in connection therewith. For the avoidance of doubt, the Second Street Improvements and the improvements to the Second Street Plaza shall constitute Infrastructure Improvements.

“Infrastructure Work” shall mean the design, development, and construction of the Infrastructure Improvements in accordance with the Stadium Development Agreement and any demolition work in connection therewith.

“Initial Campus Improvements” shall have the meaning set forth in the Recitals.

“Initial Development Area” shall have the meaning set forth in the Recitals of this Agreement.

“Land” means the Stadium Site.

“Leasehold Mortgage” shall have the meaning set forth in Section 18.2(a) of the Stadium Lease.

“Leasehold Mortgagee” shall have the meaning set forth in the Stadium Lease.

“Lease Term” shall have the same meaning as “Term” as used in the Stadium Lease.

“Legal Holiday” shall mean any day, other than a Saturday or Sunday, on which the County’s administrative offices are closed for business.

“Lessor” shall have the meaning set forth in the Stadium Lease.

“Losses” shall mean all losses, liabilities, costs, charges, judgments, claims, damages, penalties, fines, and expenses (including attorneys’ fees, except notice fees and expenses and costs of Actions or Proceedings).

“Merchandise” means souvenirs, apparel, publications (including NFL football programs), retail goods, other merchandise (including, but not limited to, NFL or team novelties and licensed items) and other non-edible items, goods, equipment (including mechanical, electrical or computerized amusement devices) and wares.

“Metropolitan Government” or “Metro” shall mean Metro of Nashville and Davidson County.

“Metro Representative” shall have the meaning set forth in Section 2.1 of this Agreement.

“Negative Advertising” means mentioning Persons that are competitive with other Persons by name or by overt reference in any advertising that is (i) visible or audible on-site or (ii) directed to patrons or fans who are on the Campus by personal electronic means (e.g., online).

“NFL” shall have the meaning set forth in the Recitals of this Agreement.

“NFL Entities” means any entity that is, directly or indirectly, jointly owned by all or substantially all of the NFL member clubs (including NFL Productions LLC, NFL Properties LLC, NFL Enterprises LLC, NFL International LLC, NFL Ventures, Inc., NFL Ventures, L.P. and any successor or future entity that is, directly or indirectly, in whole or in part, jointly owned and/or controlled by all or substantially all of the NFL member clubs or that owns assets that produce revenues that are required to be shared with other NFL member clubs under the NFL Constitution and their respective subsidiaries and other affiliates).

“NFL Management Council” shall mean the not-for-profit association formed by the member clubs of the NFL to act as the representative of such member clubs in the conduct of collective bargaining and other player relations activities of mutual interest to such member clubs.

“NFL Rules and Regulations” shall mean the Constitution and Bylaws of the NFL, including, without limitation, all resolutions, rules and policies adopted and/or promulgated thereunder, and the Articles of Association and Bylaws of the NFL Management Council, including any amendments to either such document and any interpretations of either such

document issued from time to time by the Commissioner which are within the Commissioner's jurisdiction; all operative NFL or NFL Management Council resolutions that are within the NFL's or the NFL Management Council's respective jurisdictions; any existing or future agreements entered into by the NFL or the NFL Management Council, including, without limitation, any television agreements or any collective bargaining or other labor agreements (including without limitation, any NFL player salary guarantees and pension fund agreements), and any agreements made in settlement of any litigation against the NFL, the NFL Management Council, or the NFL member clubs (including litigation against such clubs, or agreements made by such clubs, jointly or collectively); any agreements and arrangements to which such party is or after the date of this Lease may become subject or by which it or its assets are or may become bound with or in favor of the NFL and its affiliates; and such other rules or policies as the NFL, the NFL Management Council, or the Commissioner may issue from time to time that are within the issuing party's jurisdiction, including, without limitation, all financial and other reporting requirements of the NFL

“NFL Season” shall mean a period of time coextensive with the NFL season as established from time to time under the NFL Rules and Regulations (including post season).

“Non-Relocation Agreement” shall mean the Non-Relocation Agreement dated as of the Effective Date (as defined therein) by and between the Sports Authority and the Team, as the same may be amended, supplemented, modified, renewed or extended from time to time in accordance therewith.

“Notice” shall mean any Approval, consent, demand, designation, request, election or other notice that any Party gives to the other Party regarding this Agreement.

“Party” and “Parties” shall have the meaning set forth in the preamble of this Agreement.

“Person” or “Persons” shall mean any individual, corporation, partnership, joint venture, association, joint stock company, trust, limited liability company, unincorporated organization, Governmental Authority or any other form of entity.

“Personal Seat License Marketing and Sales Agreement” shall mean that certain Personal Seat License Marketing and Sales Agreement dated the date hereof by and between the Sports Authority and StadCo.

“Project Documents” shall mean collectively, this Agreement, the Stadium Lease, the Stadium Development Agreement, the Team Guaranty, the Personal Seat License Marketing and Sales Agreement, the Construction Funds Trust Agreement, and the Non-Relocation Agreement, as the same may be amended, supplemented, modified, renewed or extended from time to time in accordance with the terms thereof.

“Project Improvements” shall mean the Stadium Project Improvements and the Infrastructure Improvements.

“Project Improvements Work” shall mean the Stadium Project Improvements Work and the Infrastructure Work.

“Property” shall mean any interest in any kind of property or asset, whether real, personal or mixed, or tangible or intangible.

“Punch List” shall mean minor incomplete or defective items of construction work to be completed or corrected that do not have a material impact on the use or operation of the improvements in question.

“Related Party(ies)” shall mean with respect to any Person, such Person’s partners, directors, board members, officers, shareholders, members, agents, employees, auditors, advisors, consultants, counsel, contractors, subcontractors (of any tier), licensees, invitees, subtenants, lenders, successors, assigns, legal representatives, elected and appointed officials, volunteers, and Affiliates, and for each of the foregoing their respective partners, directors, board members, officers, shareholders, members, agents, employees, auditors, advisors, counsel, consultants, contractors, subcontractors, licensees, invitees, and subtenants. For the avoidance of doubt, Related Parties of Metro shall not include StadCo and its Related Parties and vice versa.

“Review and Approval Rights” shall have the meaning set forth in Section 11.1 of this Agreement.

“Reviewing Party” shall have the meaning set forth in Section 11.1 of this Agreement.

“SCA Term” shall have the meaning set forth in Section 3.1.

“Second Street Improvements” has the meaning set forth in Section 6.6 of this Agreement.

“Second Street Plaza” shall mean a common area adjacent to the Stadium Site to the north, Development Parcel C to the south, and 2<sup>nd</sup> Street to the west, the exact dimensions and location of which are set forth in the Declaration.

“Special Stadium Events” shall mean Stadium Events at the Stadium such as Super Bowls, NCAA tournaments, and such other similar events that may require special accommodations, such as extended hours of operation, additional seating capacity, accommodation for media coverage, etc.

“Sports Authority” shall mean The Sports Authority of the Metropolitan Government of Nashville and Davidson County, a separate governmental entity authorized pursuant to the Act, and as may be further defined in the preamble of this Agreement.

“StadCo” shall mean Tennessee Stadium, LLC, a Delaware limited liability company and shall have any additional meaning set forth in the preamble of this Agreement.

“StadCo Indemnified Persons” shall mean StadCo and its Related Parties.

“StadCo Representative(s)” shall have the meaning set forth in Section 2.2 of this Agreement.

“Stadium” shall mean a new premier, first-class, fully-enclosed venue to be constructed on the Land for professional football Team Games and a broad range of other civic, community, athletic, educational, cultural, and commercial activities.

“Stadium-Adjacent Parcels” shall have the meaning set forth in the Recitals of this Agreement.

“Stadium-Adjacent Parcels Improvements” shall mean the portion of the Campus Improvements that are located in the Stadium-Adjacent Parcels.

“Stadium-Adjacent Parcels Improvements Plans” shall have the meaning set forth in Section 5.2(b) of this Agreement.

“Stadium-Adjacent Parcels Improvements Work” shall mean the development, design and construction of the Stadium-Adjacent Parcels Improvements by the Campus Developer.

“Stadium Development Agreement” means that certain Development and Funding Agreement by and between the Sports Authority and StadCo dated on or about the date hereof.

“Stadium Event Operational Period” shall mean the following:

(a) With respect to the right of StadCo to conduct operations in the Campus Park and collect any revenues related thereto, including without limitation the exercise of Advertising Rights, Concession Rights and Hospitality Rights and the hosting of StadCo and TeamCo Events, the period that is six (6) hours (or such reasonable lesser time as is feasible under the relevant circumstances) prior to the commencement of the Stadium Event and three (3) hours (or such reasonable lesser time as is feasible under the relevant circumstances) after the end of the Stadium Event, except for Special Stadium Event which shall be a period that is subject to mutual agreement by the Parties.

(b) With respect to the right of StadCo to perform set-up and tear-down of operations within the Campus Park, including without limitation the set-up and tear-down of facilities required to exercise Advertising Rights, Concession Rights and/or Hospitality Rights and/or host StadCo and TeamCo Events, and for any other purpose not described in subsection (a), the period that is thirty-six (36) hours (or such reasonable lesser time as is feasible under the relevant circumstances) prior to the commencement of the Stadium Event and twenty-four (24) hours (or such reasonable lesser time as is feasible under the relevant circumstances) after the end of the Stadium Event, except for Special Stadium Event which shall be a period that is subject to mutual agreement by the Parties.

“Stadium Events” means Team Events, Tennessee State University football games, and any and all other events or activities of any kind at the Stadium which are permitted under the Stadium Lease, excluding events hosted by the Sports Authority, where tickets are distributed to more than 20,000 people.

“Stadium Lease” shall mean the Stadium Lease Agreement dated as of the Effective Date between the Sports Authority, as lessor, and StadCo, as lessee, and covering the Land and Stadium

Project Improvements, as the same may be amended, supplemented, modified, renewed or extended from time to time as provided therein.

“Stadium Plans” shall mean individually and collectively, the GMP Documents as defined in the CMAR Agreement and incorporated into the GMP Agreement with the CMAR and any modifications thereto for the Stadium Project Improvements prepared by the Architect and CMAR in the form Approved by StadCo and the Sports Authority in accordance with the terms of the Stadium Development Agreement.

“Stadium Project Improvements” shall mean the Stadium (including all Stadium-related furniture, fixtures and equipment and all concession improvements) and all improvements appurtenant thereto or comprising a part of any of the same and all appurtenances and amenities relating to any of the same, all as are more fully described in the CMAR Agreement and the Stadium Plans.

“Stadium Project Improvements Work” shall mean the design, development, construction, and furnishing of the Stadium Project Improvements in accordance with the Stadium Development Agreement and any demolition work in connection therewith.

“Stadium Site” is defined in the Recitals and shall have the same meaning as the term “Land” as set forth in the Stadium Lease.

“State” shall mean the State of Tennessee.

“Submitting Party” shall have the meaning set forth in Section 11.1 of this Agreement.

“Substantial Completion” shall mean that the applicable portion of the Campus Improvements is sufficiently complete such that the Campus Improvements in question can be used for its intended purposes (subject to Punch List to be completed by final completion) and all inspections and approvals from Governmental Authorities have been made and issued as required. Substantial Completion as to the Stadium Improvements has the meaning set forth in the Stadium Development Agreement.

“Team” shall mean the National Football League franchise currently known as the Tennessee Titans.

“Team Events” shall mean events at the Stadium, in addition to Team Games, that are related to the football operations of the Team or the marketing or promotion of the Team.

“Team Games” shall mean each pre-season, regular season and play-off NFL game of the Team in which the Team is designated by the NFL as the “home” team, excluding any Super Bowl, even if held at the Stadium.

“TeamCo” shall mean Tennessee Football, LLC, a Delaware limited liability company.

## RULES AS TO USAGE

1. The terms defined above have the meanings set forth above for all purposes, and such meanings are applicable to both the singular and plural forms of the terms defined.
2. “Include,” “includes,” and “including” shall be deemed to be followed by “without limitation” whether or not they are in fact followed by such words or words of like import.
3. “Writing,” “written,” and comparable terms refer to printing, typing, and other means of reproducing in a visible form.
4. Any agreement, instrument or Applicable Law defined or referred to above means such agreement or instrument or Applicable Law as from time to time amended, modified or supplemented, including (in the case of agreements or instruments) by waiver or consent and (in the case of Applicable Law) by succession of comparable successor Applicable Law and includes (in the case of agreements or instruments) references to all attachments thereto and instruments incorporated therein.
5. References to a Person are also to its permitted successors and assigns.
6. Any term defined above by reference to any agreement, instrument or Applicable Law has such meaning whether or not such agreement, instrument or Applicable Law is in effect.
7. “Hereof,” “herein,” “hereunder,” and comparable terms refer, unless otherwise expressly indicated, to the entire agreement or instrument in which such terms are used and not to any particular article, section or other subdivision thereof or attachment thereto. References in an instrument to “Article,” “Section,” “Subsection” or another subdivision or to an attachment are, unless the context otherwise requires, to an article, section, subsection or subdivision of or an attachment to such agreement or instrument. All references to exhibits or appendices in any agreement or instrument that is governed by this Appendix are to exhibits or appendices attached to such instrument or agreement.
8. Pronouns, whenever used in any agreement or instrument that is governed by this Appendix and of whatever gender, shall include natural Persons, corporations, limited liability companies, partnerships, and associations of every kind and character.
9. References to any gender include, unless the context otherwise requires, references to all genders.
10. “Shall” and “will” have equal force and effect.
11. Unless otherwise specified, all references to a specific time of day shall be based upon Central Standard Time or Central Daylight Savings Time, as applicable on the date in question in Nashville, Tennessee.
12. References to “\$” or to “dollars” shall mean the lawful currency of the United States of America.

## **EXHIBIT B**

### **CAMPUS**

#### Parcel Numbers

09302006800  
08215003000  
09303002200  
09302008700  
09303006600  
09303017400  
09303015300  
09307001000  
09303017100  
09303011500  
09307004600  
09307005100

Such parcels being lots 2, 3, 4, 5, 8, 9, 10, 11, and 12 on the Phase Two Subdivision Plat, Tennessee NFL Stadium, East Bank Redevelopment Plan, of record in Book 9700, Pages 986 and 987, R.O.D.C., and lots 13 and 14A on the Unified Plat of Subdivision of Lots 6, 13 & 14 of the Phase Two Subdivision Plat, Tennessee NFL Stadium, East Bank Redevelopment Plan, of record at Instrument No. 20100929-0077565, R.O.D.C., and lot 15 on the Resubdivision to Phase 2 Lot 15, Tennessee NFL Stadium, East Bank Redevelopment Plan, of record at Instrument No. 20100924-0076276, R.O.D.C., and further having been conveyed to Metro by deed of record at Instrument No. 20230901-0068581, R.O.D.C.



EXHIBIT C  
STADIUM SITE

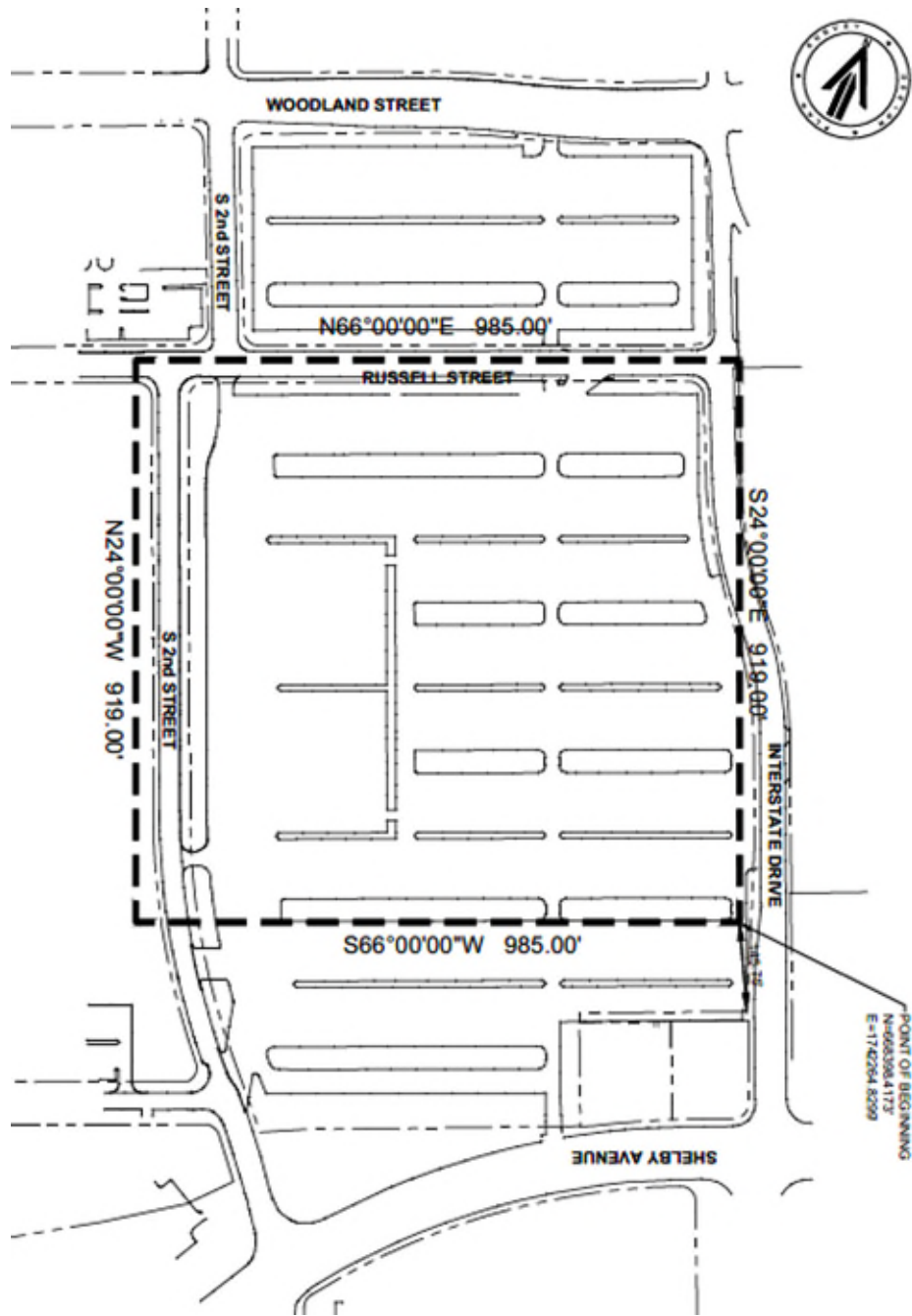

Exhibit C

Being a 100' Buffer Yard surrounding the proposed Titans Stadium. Said stadium is located in the 6<sup>th</sup> Council District of Nashville, Davidson County, Tennessee. Said Stadium is located on a part of Lot 8 and 9 as shown on the plat entitled, Tennessee NFL Stadium, of record in Plat Book 9700, page 986, Register's Office for Davidson County, Tennessee. Said lots were conveyed to The Sports Authority of the Metropolitan Government of Nashville and Davidson County, of record in Deed Book 11634, page 297, Register's Office for Davidson County, Tennessee. Said buffer is hereby described as follows:

Beginning at a point 145.75 feet northwest of the southeasterly corner of said Sports Authority, with State Plane coordinates of: N=668398.4173', E=1742264.8299';

Thence, crossing said Sports Authority and S 2<sup>nd</sup> Street, South 66°00'00" West, 985.00 feet to a point;

Thence, continuing to cross said Sports Authority and Russell Street, North 24°00'00" West, 919.00 feet to a point;

Thence, continuing to cross Russell Street and Interstate Drive, North 66°00'00" East, 985.00 feet to a point;

Thence, continuing to cross Interstate Drive and said Sports Authority, South 24°00'00" East, 919.00 feet to the point of beginning and containing 905,215 square feet or 20.78 acres, more or less.

## **EXHIBIT D**

### **EXISTING STADIUM SITE**

That certain parcel of real property located at 1 Titans Way, Nashville, Tennessee 37213, bounded on the north by Russell Street, on the east by Second Street, on the south by Victory Avenue and on the west by Titans Way, consisting of approximately 32 acres as shown on **Exhibit E**.

# EXHIBIT E

## INITIAL DEVELOPMENT AREA

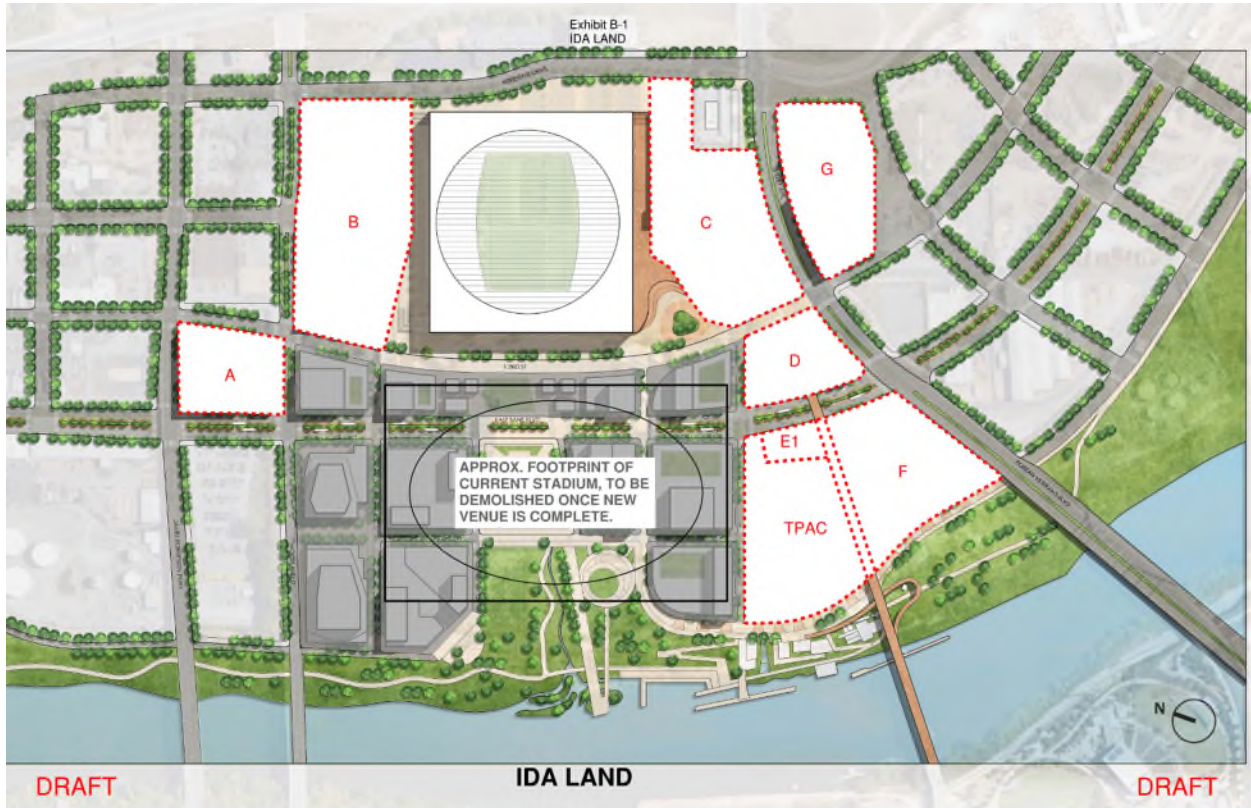

**EXHIBIT F**

**APPROXIMATE SIZE AND LOCATION OF CAMPUS PARK**



**EXHIBIT G**

**DEPICTION OF SECOND STREET PLAZA**

